

~~MASTER~~ COPY

MHI
Copy 3

FM 6-21

DEPARTMENT OF THE ARMY FIELD MANUAL

Superseded by FM 6-21

(24 Feb. 60)

RESCINDED
DIVISION ARTILLERY

INFANTRY DIVISION

PROPERTY OF
~~THE QUARTERMASTER DEPARTMENT~~
QUARTERMASTER SCHOOL
QUARTERMASTER TRAINING COMMAND
FORT LEE, VA.



HEADQUARTERS, DEPARTMENT OF THE ARMY
AUGUST 1957

FIELD MANUAL }
 No. 6-21 }

HEADQUARTERS,
 DEPARTMENT OF THE ARMY
 WASHINGTON 25, D. C., 13 August 1957

DIVISION ARTILLERY, INFANTRY DIVISION

	Paragraphs	Page
CHAPTER 1. GENERAL	1, 2	2
2. ORGANIZATION, COMMAND, AND CONTROL		
Section I. Organization	3-6	3
II. Command and Control	7-12	12
CHAPTER 3. TACTICAL EMPLOYMENT		
Section I. Principles of Employment	13, 14	16
II. Organization for Combat	15-20	17
III. Security	21, 22	22
IV. Army Aviation	23-26	23
CHAPTER 4. INTELLIGENCE		
Section I. General	27-30	25
II. Observation	31-33	26
III. Survey	34-39	27
CHAPTER 5. FIRE SUPPORT PLANNING		
Subject I. Coordination	40-45	31
II. Fire Planning	45-51	34
CHAPTER 6. COMMUNICATIONS	52-56	37
7. GUNNERY	57-62	50
8. ADMINISTRATION	63-69	53
APPENDIX I. REFERENCES		55
II. COMMON NUMBERING SYSTEM FOR CONCENTRATIONS		57
INDEX		59

CHAPTER 1

GENERAL

1. Purpose and Scope

This manual is a guide for artillery officers and commanders and their staffs of all combat arms. It is concerned with the tactical employment of the infantry division artillery. FM 6-20, FM 6-101, and FM 6-140 will continue to provide the basic doctrine while this manual covers the characteristics, organization, communications, and employment that differ from that doctrine.

2. Application

The material presented herein is applicable without modification to both atomic and nonatomic warfare.

CHAPTER 2

ORGANIZATION, COMMAND, AND CONTROL

Section I. ORGANIZATION

3. Division Artillery, Infantry Division

- a. The division artillery is organized as a tactical unit.
- b. The division artillery consists of a division artillery headquarters and headquarters battery, a 105-mm howitzer battalion, and a composite battalion (fig. 1).

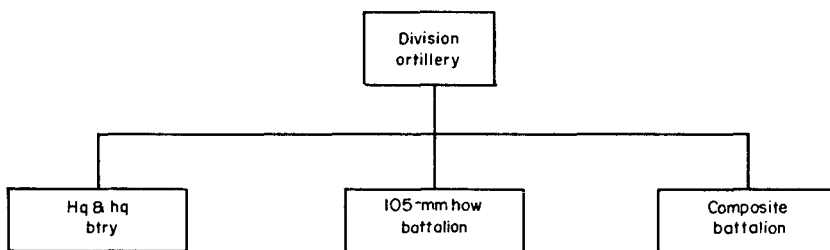

Figure 1. Division artillery.

4. Headquarters and Headquarter Battery, Division Artillery

An organizational diagram of headquarters and headquarters battery, division artillery, is shown in figure 2.

5. Field Artillery Howitzer Battalion, 105-mm, Towed

The field artillery howitzer battalion, 105-mm, towed, is organized as a tactical and administrative unit and is self-sustaining. The battalion consists of headquarters and headquarters battery, service battery, and five 105-mm howitzer batteries (fig. 3).

- a. The headquarters and headquarters battery is organized as shown in figure 4.
- b. The service battery consists of a battery headquarters, a battalion supply section, a battalion maintenance section, a battalion personnel section, and an ammunition train which contains an ammunition train headquarters and five ammunition sections (fig. 5).

- c. Each 105-mm howitzer battery consists of a battery headquarters, a battery detail, a liaison section, two forward observer (FO) sections, an ammunition section, and a firing battery. The firing battery consists of a firing battery headquarters, a fire direction center (FDC), and 2 firing platoons of 3 howitzer sec-

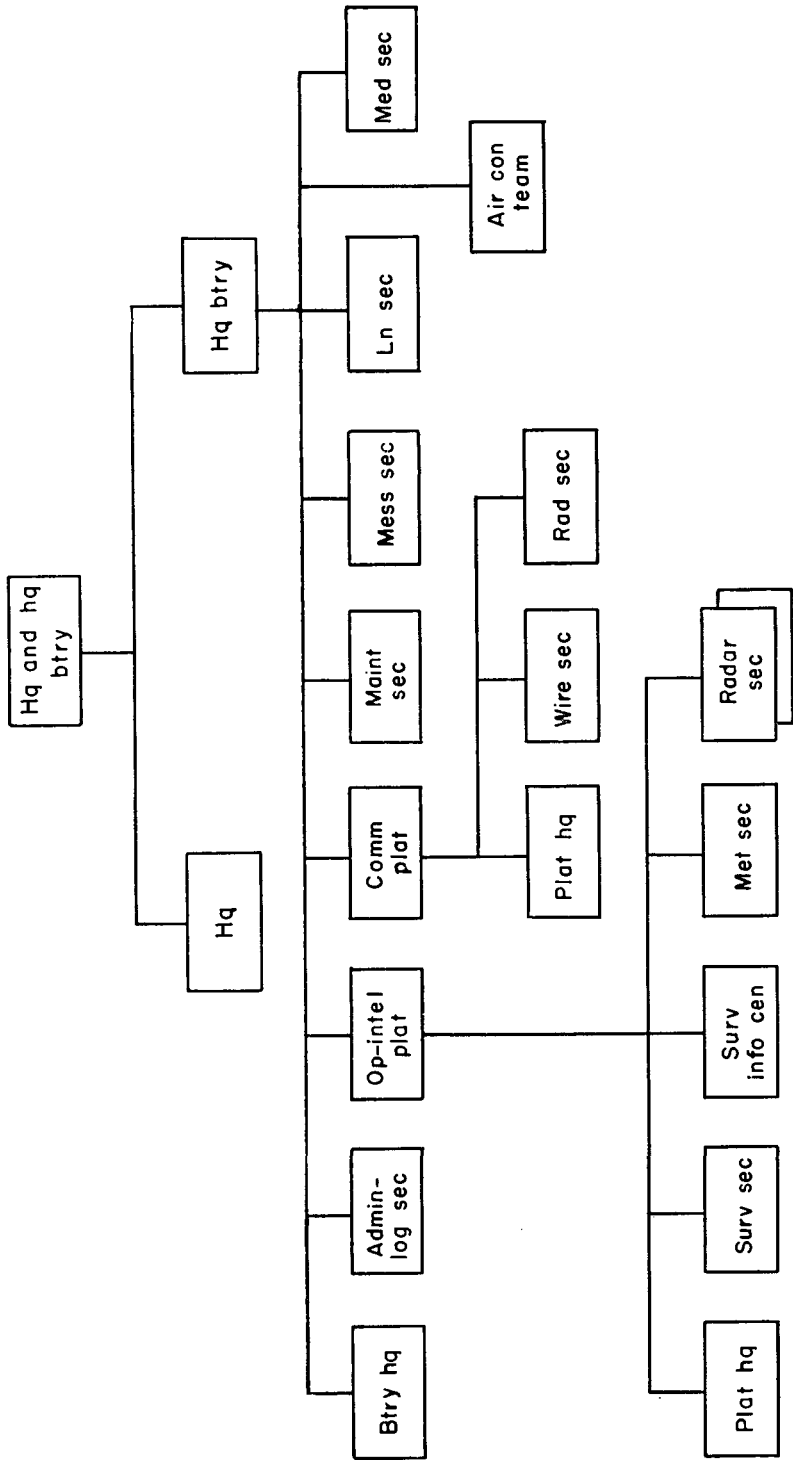

Figure 2. Headquarters and headquarters battery, division artillery.

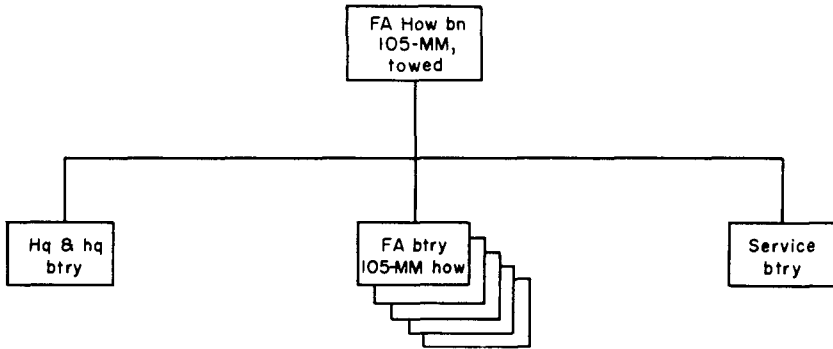

Figure 3. Field artillery howitzer battalion, 105-mm, towed.

tions each. When augmentation is authorized, the battery will have 2 firing platoons of 4 howitzers each (fig. 6).

6. Field Artillery Composite Battalion

The field artillery composite battalion is organized as a tactical and administrative unit and is self-sustaining. The battalion consists of a headquarters and headquarters battery, a service battery, two 155-mm howitzer batteries, an 8-inch howitzer battery, and a 762-mm rocket battery (fig. 7).

a. The headquarters and headquarters battery of the composite battalion is organized the same as the 105-mm howitzer battalion headquarters and headquarters battery shown in figure 4.

b. The service battery consists of a battery headquarters; battalion supply, maintenance, and personnel sections; and an ammunition train which contains an ammunition train headquarters and four ammunition sections (fig. 8).

c. The field artillery howitzer batteries, 155-mm, towed, consist of a battery headquarters, a battery detail, a forward observer section, and a firing battery. The firing battery consists of a firing battery headquarters, an ammunition section, and six 155-mm howitzer sections (fig. 9).

d. The field artillery howitzer battery, 8-inch, towed, consists of a battery headquarters, a battery detail, a forward observer section, and a firing battery. The firing battery consists of a firing battery headquarters and four 8-inch howitzer sections (fig. 10).

e. The field artillery missile battery, 762-mm rocket, SP, consists of a battery headquarters, a battery detail, a fire direction center, an assembly section, and two firing platoons. The battery detail consists of the battery detail headquarters, a survey section, and a wire section. Each firing platoon consists of a firing platoon headquarters and a firing section containing one 762-mm rocket launcher (fig. 11).

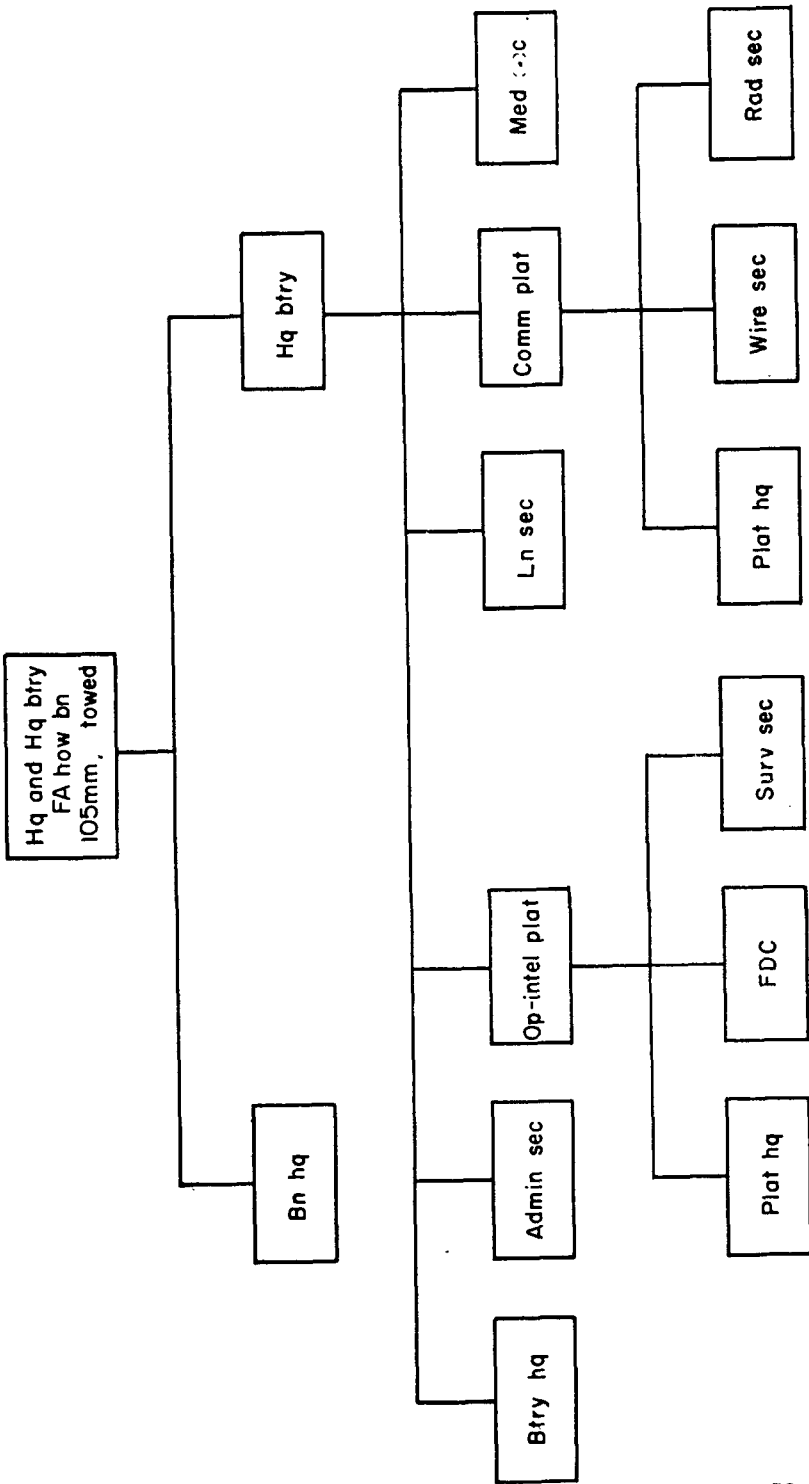

Figure 4. Headquarters and headquarters battery, field artillery howitzer battalion, 105-mm, towed.

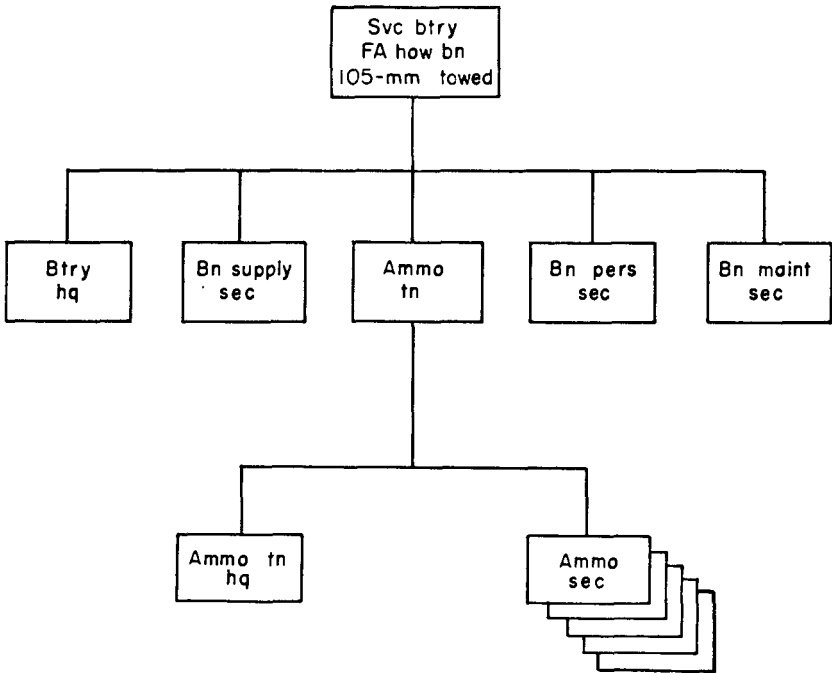

Figure 5. Service battery, field artillery howitzer battalion, 105-mm, towed.

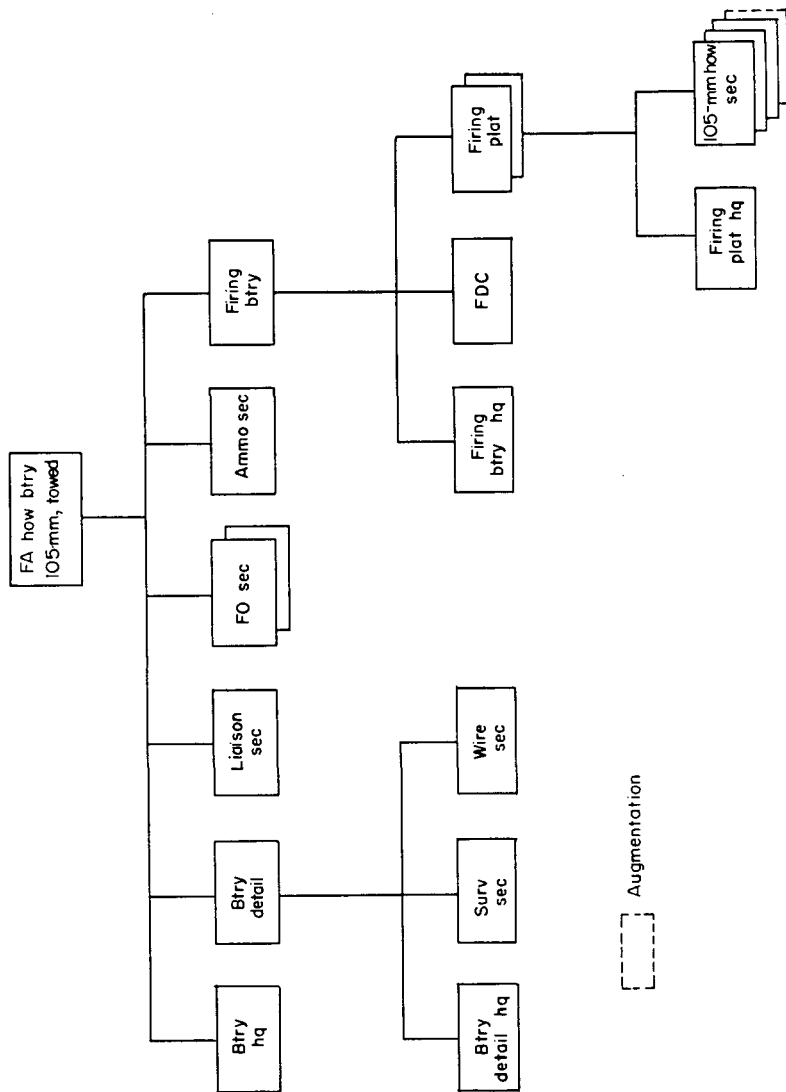

Figure 6. Field artillery howitzer battery, 105-mm, towed.

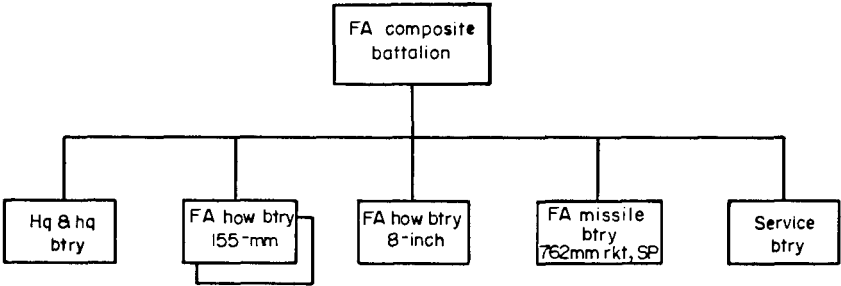

Figure 7. Field artillery composite battalion.

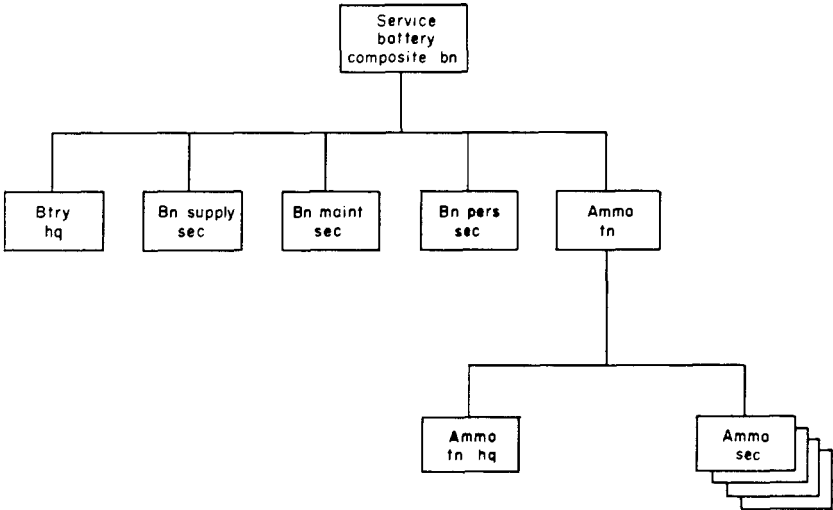

Figure 8. Service battery, field artillery composite battalion.

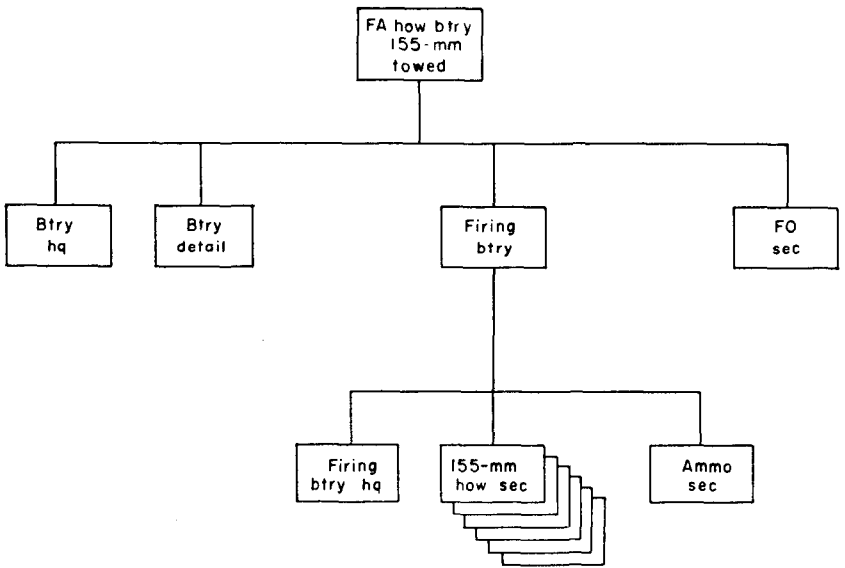

Figure 9. Field artillery howitzer battery, 155-mm, towed.

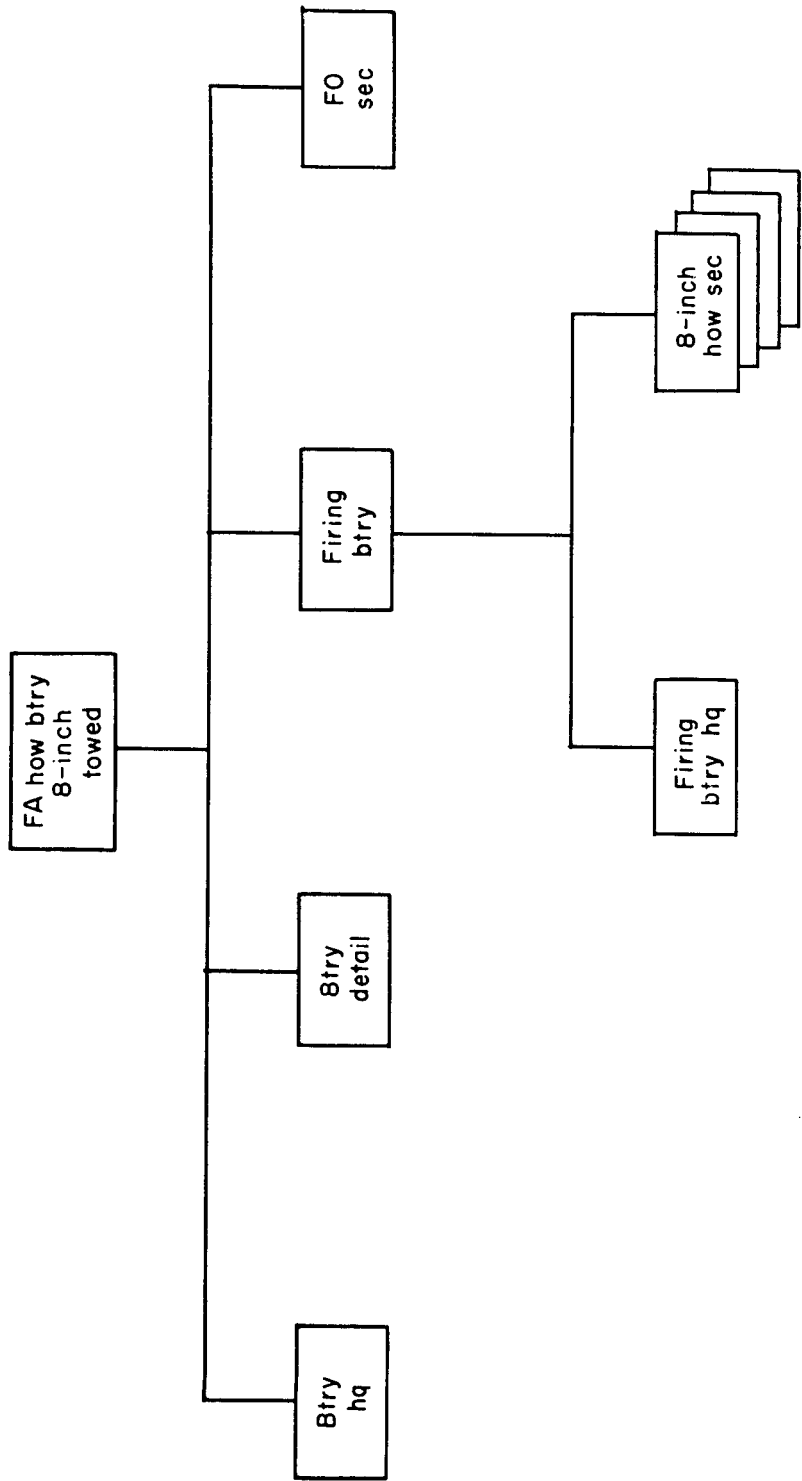

Figure 10. Field artillery howitzer battery, 8-inch, towed.

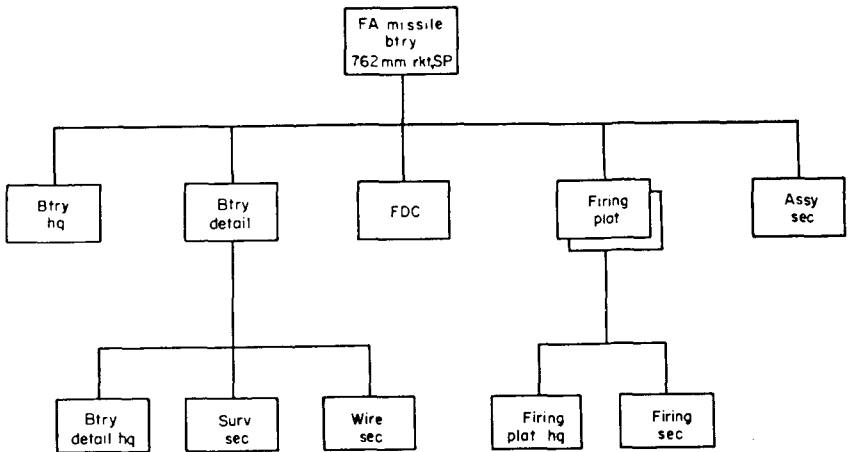

Figure 11. Field artillery missile battery 762-mm rocket, SP.

Section II. COMMAND AND CONTROL

7. Division Artillery Staff

The division artillery staff is organized as shown in figure 12.

8. Duties of the Division Artillery Staff

The duties and responsibilities of the division artillery commander and his staff include duties enumerated in FM 6-20 and FM 101-5 and those listed in *a* through *d* below.

a. Division Artillery Commander. Considering that there are only 2 artillery battalions to support 5 battle groups and also the large area for which artillery support must be provided, the division artillery commander must exercise more detailed control, supervision, and direction than was previously required in artillery operations above firing unit level. The division artillery commander is responsible for—

- (1) The establishment of common survey control throughout the division area, to include that required by units not organic to division artillery to facilitate accurate fire support.
- (2) Obtaining logistical support for all units of division artillery from the division trains.
- (3) Assisting, as directed by the division commander, in the technical field artillery training of personnel in the mortar batteries organic to the battle groups and making recommendations to the battle group commanders concerning their tactical employment.
- (4) Establishing communication with the mortar batteries at

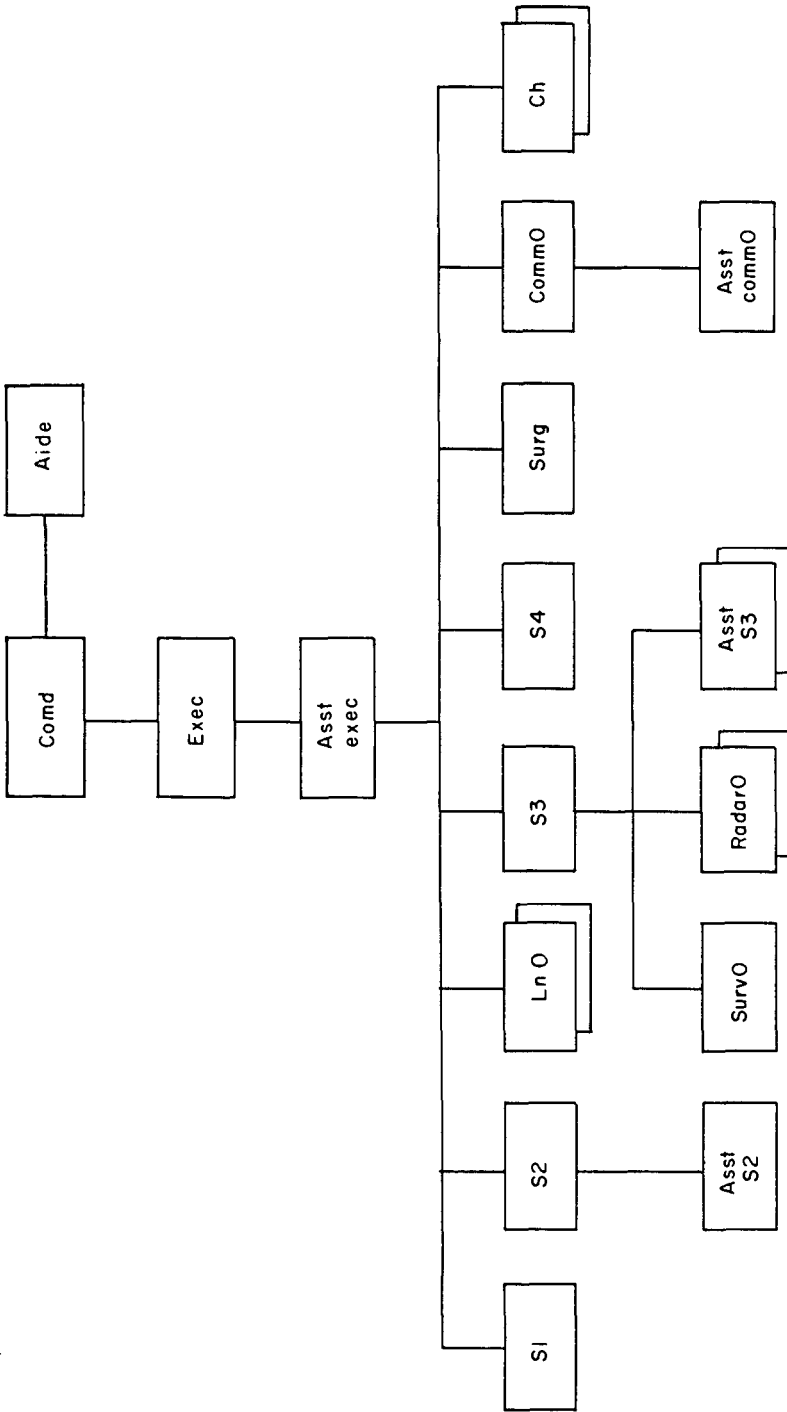

Figure 12. Division artillery staff.

the earliest practicable time to facilitate the delivery of supporting fires.

b. Division Artillery Executive. The division artillery executive, in addition to his normal duties, exercises overall supervision over local defense measures of the artillery units operating under division artillery control.

c. Division Artillery Assistant Executive. The division artillery assistant executive represents the division artillery commander at the division CP (par. 42).

d. Fire Direction Officer. The division artillery S3 is the fire direction officer (FDO) and is in charge of the operation of the fire direction center (par. 59).

9. Duties of the Battalion Commander

The battalion commander's duties and responsibilities are those discussed in FM 6-20 and FM 6-101. They include the following when the mission of the battalion is general support or general support reinforcing the fires of 1 or more mortar batteries with 1 battery of 105-mm howitzers each :

a. Establish communication with the mortar batteries directly or through the reinforcing howitzer battery.

b. Facilitate extension of division artillery survey control to the mortar batteries by providing survey control points in the vicinity of the mortar batteries.

c. Answer calls for fire from the mortar battery whether received direct or relayed through the reinforcing howitzer battery.

10. Duties of the Battery Commander

The battery commander is responsible for all activities of his unit. When he is engaged in active operations, his functions and responsibilities concerning observation, liaison, communications, fire support, survey, fire direction, and selection of position will be as required by the assigned tactical mission as modified by the headquarters assigning the mission and based on capabilities and limitations of the unit.

a. When a battery is directly under the operational control of division artillery, reinforcing a mortar battery, or attached to a supported command, the responsibilities of the battery commander are comparable to those of a battalion commander as discussed in FM 6-20, FM 6-61, and FM 6-101.

b. When a battery is under the operational control of a field artillery battalion, the responsibilities of the battery commander are as discussed in FM 6-140.

11. Duties of Liaison Officers

The duties of liaison officers are as outlined in FM 6-20 and FM 6-101. Liaison personnel may be utilized by the various division artillery echelons as follows:

a. Two liaison officers and one liaison section are organic to headquarters and headquarters battery, division artillery. The liaison officer without a section is a qualified special weapons officer who assists the division artillery assistant executive (par. 8*c*). The liaison officer with a section establishes liaison with an adjacent division artillery or performs duties as directed by the division artillery commander.

b. One liaison officer and section is organic to the headquarters and headquarters battery of each of the artillery battalions. When the battalion is assigned a mission of general support, the liaison responsibilities of the battalion are as directed by division artillery. In this situation, division artillery may utilize one of the liaison sections to establish liaison with the cavalry squadron to expedite the flow of target information to division artillery—particularly that obtained by the reconnaissance and surveillance platoon (Sky Cav). When a battalion is assigned a mission of direct support of a task force, normal liaison is established with the supported headquarters.

c. The liaison officer and section organic to each 105-mm howitzer battery perform normal liaison functions for the battery when the battery is assigned the tactical mission of reinforcing the fires of a mortar battery or direct support of a task force. When a battle group is in reserve, liaison to the mortar battery of that battle group will be maintained by a division artillery unit. It is desirable that this liaison be maintained by the howitzer battery which is to be prepared to reinforce the fires of the mortar battery when the battle group is committed.

12. Duties of the Artillery Flight Commander

The artillery flight commander from the division aviation company acts in the capacity of a special staff officer and advises the division artillery commander concerning the utilization and employment of Army aircraft supporting division artillery. He provides information concerning Army aircraft operating in battle group areas and provides flights as required by the division artillery commander or his designated representative. During his absence from the division artillery command post, he is represented by a liaison officer.

CHAPTER 3

TACTICAL EMPLOYMENT

Section I. PRINCIPLES OF EMPLOYMENT

13. General

Principles governing employment of the division artillery are essentially the same as those discussed in FM 6-20 and FM 6-101, as modified by paragraphs 14 through 18.

14. Considerations Governing Employment of the Division Artillery

a. The principles of maneuver, surprise, and economy of force as applied to artillery assume increased importance to the division artillery commander owing to range capabilities of weapons, the area of the division sector (width and depth) over which fires must be brought to bear, and the presence of an atomic capability.

b. Owing to the size of the area occupied by the division (width and depth) and the required distribution of various caliber batteries throughout that area, proper tactical dispositions will normally require that some batteries be deployed under operational control of other than their parent battalion.

c. In areas designated by the division artillery commander, each division artillery battalion may be assigned responsibility for activities considered essential to the success of the artillery mission. These activities may include coordination of observation, establishment of common survey control, installation of artillery communications, countermortar programs, preliminary target analysis, shell reports and crater analysis, and fire planning to augment that accomplished by the mortar batteries of the battle groups. Assignment of these responsibilities may be made in the operation order, fire support plan, standing operating procedure, or in any other manner considered appropriate by the division artillery commander.

d. The mortar battery organic to each battle group provides close continuous fire support to the battle group. The assignment of a tactical mission of direct support to a division artillery unit may be made when required to support a battle group in the event the mortar battery is detached from the battle group, or to support a task force not organized around a battle group.

e. Batteries having an atomic capability will normally be under the operational control of division artillery.

Section II. ORGANIZATION FOR COMBAT

15. General

Objectives and considerations in organizing the division artillery for combat are essentially the same as those discussed in FM 6-20, modified as indicated in paragraphs 16 through 20. Among all of the considerations listed in FM 6-20, certain specific factors are analyzed to arrive at a suitable organization for combat. These factors are the mission of the force, the plan of maneuver or scheme of defense, centralized versus decentralized control, weapons capabilities, availability of suitable position areas, capabilities and limitations of current and planned tactical groupings, and future operations.

16. Organizing the Division Artillery for Combat

The division artillery organization for combat is patterned to provide the most effective support for the assault elements of the division in the offense or the elements in contact in the defense. Operational control of batteries by battalions or division artillery will vary as the tactical situation dictates.

a. The division artillery headquarters battery will operate as outlined in FM 6-20.

b. The two battalion headquarters will operate under a flexible concept. Batteries of various calibers will be placed under the operational control of these headquarters as required by the tactical situation.

c. The 105-mm howitzer batteries are normally employed under the control of division artillery battalions but may operate separately under division artillery control or in support of a task force. Employment of these batteries by platoon is not recommended. However, when the situation dictates, displacement by platoon or utilization of a separate platoon for a limited length of time is within the capabilities of the battery. Consolidation should be effected at the earliest practicable time. Platoons are not capable of independent operation without major augmentation from the battery.

d. The 155-mm howitzer batteries will normally be employed under the control of a division artillery battalion.

e. The 8-inch howitzer battery may be employed as a battery under division artillery control or it may be employed as a whole or in part under the control of the division artillery battalions. The battery is not organized in platoons in the tables of organization and equipment (TOE). However, it may be employed as a battery (minus) and a separate platoon. In organizing a platoon

for separate operation, consideration is given to the communications, survey, security, and other support the platoon will require to accomplish its mission. These problems can be solved with the assistance of the parent battalion and by having the platoon positioned near, and receive support from, another artillery unit.

f. The 762-mm rocket battery will normally be employed as a battery directly under the operational control of division artillery.

17. Tactical Missions

A tactical mission is the fire support responsibility that may be assigned to an artillery unit. Tactical missions that may be assigned to artillery units are direct support, general support, and reinforcing, or modifications of these missions. The responsibilities inherent in each type of tactical mission are given in FM 6-20.

18. Assignment of Missions

The division artillery commander may assign missions to battalions or to individual batteries. He does not assign missions to the mortar batteries of the battle group unless they have been placed under division artillery control.

a. *Direct Support.* The assignment of a tactical mission of direct support may be made to a division artillery unit when such a unit is required to support a battle group that is minus its organic mortar battery. A direct support mission is also applicable to a division artillery unit placed in support of a task force not organized around a battle group (e.g., a task force organized around a tank or cavalry unit), when such a task force is operating within mutual supporting range of the remainder of the division. Within the battle group a direct support mission is assigned to the mortar battery or a platoon thereof when it is placed in support of an element(s) of the battle group, or in support of a small task force that is operating within mutual supporting range of the remainder of the battle group.

b. *General Support.* The general support mission is appropriate for assignment to the battalions of division artillery or any of the batteries. It will normally be modified as indicated in *d* below.

c. *Reinforcing.* A reinforcing mission may be assigned to a division artillery battalion or battery or to a mortar battery. It is a normal mission for a 105-mm howitzer battery or mortar battery attached to a battle group to augment the fires of the organic mortar battery. It may be assigned to 105-mm howitzer batteries retained under division artillery control or to mortar batteries placed under division artillery control and given the task

of augmenting the fires of another mortar battery. A battery may be assigned a reinforcing mission without withdrawing control of the battery from the battalion.

d. Modifications of Tactical Missions.

- (1) The tactical mission of general support, reinforcing, is a modification of the general support mission which is particularly applicable to the battalions of division artillery. These battalions will normally be assigned a mission of general support, modified to include a responsibility for reinforcing the mortar battery of designated battle groups with a 105-mm howitzer battery each. Whenever practicable, a specific 105-mm howitzer battery habitually supports the same battle group to facilitate teamwork. The reinforcing artillery commander maneuvers his unit to conform with the plan of the supported unit commander. Reinforcing artillery remains under command of the higher artillery commander, but its fires are not taken away from the supported unit except by authority of the division or force commander. This authority normally is delegated to the division artillery or force artillery commander. This arrangement minimizes the time required by the reinforcing unit in answering calls for fire and by the reinforced unit in obtaining a large volume of fire. It also provides the force commander a better reserve of fire with which to influence the action.
- (2) Requirements for artillery support in specific situations may dictate other modifications. In each case, the modification must be clearly stated by the commander assigning the mission.
- (3) Since the tactical mission of direct support requires full use of all elements of the artillery unit, it normally should not be modified.

19. Type Organization for Combat

Type division artillery organizations for combat and examples of how they may appear in the division operation order are as follows (see appendix II for designation of letter batteries by type) :

a. Example A.

* * * * *

3. Execution

* * * * *

f. Div Arty

(1) 1st How Bn:

- Btry A, 1st How Bn
- Btry B, 1st How Bn
- Btry D, 1st How Bn
- Btry F, 2d FA Bn
- Btry H (-), 2d FA Bn

GS; priority of fires to 1st, 2d, and 4th Bat Gp; reinf mort btry 1st and 2d Bat Gp with one 105-mm how btry each; prepare to reinf mort btry 4th Bat Gp with one 105-mm how btry when committed.

(2) 2d FA Bn:

- Btry C, 1st How Bn
- Btry E, 1st How Bn
- Btry G, 2d FA Bn
- 1 Plat, Btry H, 2d FA Bn

GS; priority of fires to 3d and 5th Bat Gp; reinf mort btry 3d Bat Gp with one 105-mm how btry; prepare to reinf mort btry 5th Bat Gp with one 105-mm how btry when committed.

(3) Btry I, 2d FA Bn: GS.

* * * * *

b. Example B.

* * * * *

3. Execution

* * * * *

f. Div Arty

Task Orgn:

<i>1st How Bn</i>	<i>2d FA Bn</i>	<i>Div Arty</i>
Btry A, 1st How Bn	Btry C, 1st How Bn	Btry H, 2d FA Bn
Btry B, 1st How Bn	Btry E, 1st How Bn	Btry I, 2d FA Bn
Btry D, 1st How Bn	Btry G, 2d FA Bn	
Btry F, 2d FA Bn		

(1) *1st How Bn*: GS in zones of 1st, 2d, and 4th Bat Gp; reinf mort btry 1st and 2d Bat Gp with one 105-mm how btry each; prepare to reinf mort btry 4th Bat Gp with one 105-mm how btry when committed.

(2) *2d FA Bn*: GS in zone of 3d and 5th Bat Gp; reinf mort btry 3d Bat Gp with one 105-mm how btry; prepare to reinf mort btry 5th Bat Gp with one 105-mm how btry when committed.

(3) Btry H, 2d FA Bn: GS.

(4) Btry I, 2d FA Bn: GS.

* * * * *
c. *Example C.*

* * * * *

3. Execution

* * * * *

f. *Div Arty*

(1) 1st How Bn:

Btry A, 1st How Bn

Btry F, 2d FA Bn

Btry H (-), 2d FA Bn

GS; ZF-Z/A 1st Bat Gp; comm to mort btry, 1st Bat Gp;
answer calls for fire from 1st Bat Gp.

(2) 2d FA Bn:

Btry B, 1st How Bn

Btry C, 1st How Bn

Btry G, 2d FA Bn

1 Plat, Btry H, 2d FA Bn

GS; ZF-Z/A 2d and 3d Bat Gp; reinf fires mort btry
2d and 3d Bat Gp with one 105-mm how btry each.

(3) Btry D, 1st How Bn: Reinf mort btry 4th Bat Gp.

(4) Btry E, 1st How Bn: DS task force SMITH.

(5) Btry I, 2d FA Bn: GS.

* * * * *

d. *Example D.*

* * * * *

3. Execution

* * * * *

f. *Div Arty*

(1) 1st How Bn:

Btry A, 1st How Bn: Reinf mort btry 1st Bat Gp.

Btry B, 1st How Bn: GS; reinf mort btry 2d Bat Gp.

Btry C, 1st How Bn: GS in zone 1st and 2d Bat Gp.

Btry F, 2d FA Bn: GS in zone 1st and 2d Bat Gp.

Control and coordinate div arty support in zones of 1st,
2d, and 3d Bat Gp; assign Btry C, 1st How Bn, mission
of reinf mort btry 3d Bat Gp when committed.

(2) 2d FA Bn:

Btry D, 1st How Bn: GS; reinf mort btry 4th Bat Gp.

Btry E, 1st How Bn: Reinf mort btry 5th Bat Gp.

Btry G, 2d FA Bn: GS in zone 4th and 5th Bat Gp.

Btry H, 2d FA Bn: GS; posit and fires as directed by div
arty.

Control and coordinate div arty support in zones 4th and
5th Bat Gp.

(3) Btry I, 2d FA Bn: GS.

* * * * *

20. Explanation of Missions

In the examples in paragraph 19, the 762-mm rocket battery is directly under division artillery control with a mission of general support of the division as a whole. Example A shows the two division artillery battalions organized for combat with a modified mission of general support, reinforcing, with priority of fires to specified units. Example B is the task organization type of order showing the two division artillery battalions organized for combat with a modified mission of general support, reinforcing, in a specified zone and the 8-inch howitzer battery directly under division artillery control with a mission of general support of the division as a whole. Example C shows one division artillery battalion organized for combat with a mission of general support and a designated primary zone of fire; the other division artillery battalion organized for combat with a modified mission of general support, reinforcing, and a designated primary zone of fire; and two 105-mm howitzer batteries directly under division artillery control, one with a reinforcing mission, the other with a mission of direct support of a task force. In Example D, the two division artillery battalions are organized for combat with tactical missions assigned to individual batteries of the battalions rather than to each battalion. This type of organization for combat is particularly useful when operations are being conducted over areas of considerable width and depth. The two battalion headquarters control and coordinate division artillery support as indicated in the example. The detailed duties involved in this responsibility are specified by the division artillery commander, and may include those mentioned in paragraph 14c. Each battalion commander is responsible for the displacement of subordinate units with a general support or modified general support mission. Subordinate units with a reinforcing mission normally displace when requested by the reinforced artillery. All subordinate units have responsibilities inherent in assigned missions.

Section III. SECURITY

21. Security Against Ground Attack

Security of division artillery batteries against ground attack becomes more critical as a result of gaps caused by dispersion between battle groups. Artillery units must be so positioned that

they successfully accomplish their mission and also receive the required amount of protection from infantry and armor units without diverting those units from their primary mission. Additional troops normally will not be furnished artillery units for providing local security, and other combat units will not normally be assigned the primary mission of protecting field artillery units. Each unit of the division artillery is responsible for its own local security; coordination is effected with adjacent units, and the division artillery executive officer exercises overall coordination over local defense measures of division artillery units. Special security protection may have to be provided to atomic delivery elements.

22. Security Against Air Attack

The infantry division is without organic antiaircraft artillery. Therefore, the division must rely primarily on friendly tactical air or corps antiaircraft artillery for active air defense. Passive air defense must be exercised continually. This defense includes dispersion, camouflage, concealment, light discipline, and other deceptive means. The zone air defense is established and operated by corps antiaircraft units. When a division is operating in a situation not compatible with this zone air defense system, the corps may attach an antiaircraft artillery battalion to the division. The battalion operates under the control of division artillery as covered in FM 6-20 and FM 6-101.

Section IV. ARMY AVIATION

23. General

All aircraft organic to the division are assigned to the division aviation company. The artillery flight of the division aviation company provides aircraft for division artillery.

24. Control

The artillery flight provides direct support to division artillery in combat. During active combat operations, it may function either under division control or under the operational control of the division artillery commander or a subordinate unit. The decision to decentralize control will include consideration of the degree of air traffic control required, the necessity for operation from a separate airfield and/or airstrips, and the availability of aviation facilities.

25. Command

The artillery flight commander advises the division artillery

commander concerning the utilization and employment of the Army aircraft and employs aircraft as required by the artillery commander.

26. Missions

Some of the missions for which aircraft from the artillery flight may be utilized are as follows:

- a.* Aerial observation (par. 33).
- b.* Aerial photography (par. 33).
- c.* Route reconnaissance.
- d.* Wire laying and radio relay.
- e.* Resupply.
- f.* Administrative flights.
- g.* Aeromedical evacuation.
- h.* Air inspection of camouflage.
- i.* Battlefield illumination.
- j.* Survey assistance.
- k.* Column control.
- l.* Courier service.

CHAPTER 4

INTELLIGENCE

Section I. GENERAL

27. General

Within the division artillery of the infantry division, facilities for gathering target information are organic to all artillery batteries except the 762-mm rocket battery. The division artillery and artillery battalion S2's utilize the intelligence personnel of the operations and intelligence platoons to assist in developing and executing an integrated and coordinated target acquisition plan. Each facility available to the division artillery is carefully integrated into the target acquisition scheme and is exploited to the fullest capability. The division artillery S2 forwards to the division G2 all information affecting the division's essential elements of information and target locations obtained by the intelligence facilities of the division artillery.

28. Intelligence Personnel

Personnel available to assist the division artillery S2 include the assistant S2 (countermortar), the intelligence sergeant, and the assistant intelligence sergeant. Each battalion S2 is assisted by an intelligence sergeant. Intelligence personnel work closely with the fire direction center at artillery battalion and division artillery levels.

29. Intelligence Agencies

a. The target information gathering agencies organic to the division artillery consists primarily of—

- (1) The forward observer sections in the 105-mm, 155-mm and 8-inch howitzer batteries.
- (2) Two radar sections in division artillery headquarters and headquarters battery.
- (3) Artillery air observers provided as an augmentation to the TOE of the headquarters and headquarters battery of division artillery and the TOE of the headquarters and headquarters battery of each division artillery battalion. The aircraft for these activities are provided by the artillery flight of the division aviation company.

b. The forward observer sections in each mortar battery and the battle group counterfire squad, although not organic to the

division artillery, provide an additional means of obtaining target information.

c. Other available sources of target information are presented in FM 6-20 and FM 30-5.

30. Meteorology

An electronic meteorological (met) section is organic to division artillery headquarters and headquarters battery and provides meteorological information to division artillery battalions, the mortar batteries, and any other units within the division area requiring this information. Meteorological techniques and procedures techniques and procedures applicable to this section are discussed in TM 6-242.

Section II. OBSERVATION

31. General

The coordination of all artillery observation agencies is accomplished by the division artillery S2 in accordance with established doctrine. Ground observation agencies include the forward observer sections organic to the 105-mm, 155-mm, and 8-inch howitzer batteries of division artillery, observation post (OP) parties which may be furnished from division artillery survey sections, and the two division artillery radar sections. In addition, the forward observer sections of the mortar batteries, although not under division artillery control, are considered a part of the artillery ground observation scheme of the division. Air observation is used to supplement ground observation.

32. Ground Observation

The ground observation agencies are coordinated to provide coverage of the operational area.

a. *Observation Posts.* The forward observer sections of the 105-mm, 155-mm and 8-inch howitzer batteries are used to establish observation posts. In establishing these observation posts, the capabilities of the mortar battery forward observers are considered in order to obtain maximum coverage of the operational area. The observation posts are augmented with other observation posts established by survey personnel when survey requirements will permit. Plans for utilization of survey personnel are coordinated between the division artillery S2 and the division artillery reconnaissance and survey officer. When possible, observation posts are combined to form target area bases, located on common survey control, as rapidly as the situation permits.

b. Radars. The countermortar radars are employed as far forward as feasible. They are located in the immediate vicinity of a battery that is positioned well forward in order to facilitate communications, survey, security, and logistic support. One radar is normally attached to each of the two battalions. Countermortar information from the radar is furnished direct to the FDC of one or more batteries or to the battalion FDC of the battalion to which the radar is attached. The battery or battalion FDC concerned then forwards this information, together with the action taken, to the division artillery FDC.

33. Air Observation and Air Photography

a. Army aircraft for employment in division artillery air observation missions are provided by the artillery flight of the division aviation company. Artillery air observers are provided by augmentation to the artillery TOE. Flights are scheduled to accomplish continuous observation of the operational area when conditions permit. Additional air observation may be provided through the medium of flights scheduled by the division G2.

b. The artillery flight may be augmented by the company with the necessary photographic equipment and aircraft to provide limited aerial photography for artillery targets. Such photography materially assists in the delivery of effective countermortar and counterbattery fires.

Section III. SURVEY

34. General

A detailed discussion of survey methods and techniques, duties of personnel, and survey planning is contained in TM 6-200.

35. Survey Planning

Inasmuch as the division artillery may be employed over an extended area, survey operations at all echelons must be carefully planned to insure that survey control is established as expeditiously as possible. It will be necessary for each survey echelon to initiate operations without delay, using the best starting data available, and to convert to the grid of the next higher echelon as common control is established. The initial survey operations will be directed toward the completion of position area surveys by all batteries, the location of the countermortar radars, and the establishment of a common grid. Artillery units reinforcing the battle group mortar batteries should be placed on common control with the mortar batteries in the initial phase. After the initial phase is completed and if the tactical situation permits, it may be desirable

to establish target area bases for division artillery and the artillery battalions, to locate alternate or supplementary positions and to establish common survey control for division artillery units and the mortar batteries organic to the battle groups. The survey operations necessary to accomplish these additional missions must be closely coordinated by the various reconnaissance and survey officers to avoid duplication of effort. Any survey personnel available may be utilized to perform these operations and to operate the observation posts established by division artillery or the battalions. The accuracy capability of the parties must be considered in the assignment of additional missions.

36. Division Artillery Survey Operations

a. A reconnaissance and survey officer is assigned to the staff of the division artillery commander. A survey section composed of two 10-man survey parties is assigned to headquarters and headquarters battery, division artillery. A chief artillery surveyor, who functions as chief of one of the parties during field operations, acts as chief of the survey section and assists the reconnaissance and survey officer in the planning and coordination of survey operations.

b. The division artillery survey section performs the survey operations necessary to extend control from the division artillery survey control point to a survey control point established by each artillery battalion and by each battery placed directly under division artillery control. The division artillery survey control is extended to each mortar battery either through the artillery battalion in its vicinity or direct by the division artillery survey section. The countermortar radars are tied into the division artillery survey either by the artillery battalion to which attached or by the division artillery survey section.

c. The division artillery survey information center, composed of a chief artillery survey specialist and two survey computers, is employed in accordance with established doctrine as discussed in TM 6-200.

37. Artillery Battalion Survey Operations

a. A reconnaissance and survey officer is assigned to the staff of each battalion commander. A survey section composed of one 8-man survey party is assigned to headquarters battery.

b. The artillery battalion survey section performs the survey operations necessary to extend control from the battalion survey control point to a survey control point established by each firing battery of the battalion and to any other installations under

battalion control that require survey control. The additional installations may include a countermortar radar section and a platoon of 8-inch howitzers, in the event the 8-inch howitzer battery is employed by platoons. The battery survey control point for the 155-mm howitzer batteries should be located close to the battery positions since these batteries are not organized to perform extensive survey operations.

38. Firing Battery Survey Operations

a. 105-mm Howitzer Battery. The battery reconnaissance and survey officer is the leader of the battery detail. He is assisted in the performance of survey duties by the chief of detail. A survey section composed of one 8-man survey party is assigned to the battery detail. The battery survey section performs the survey operations necessary to extend control from the battery survey control point to the position area for the location of the battery (firing platoon) center and establishment of orienting lines.

b. 155-mm Howitzer Battery. The battery reconnaissance and survey officer supervises the operations of the battery detail. He is assisted in the performance of survey duties by the chief of detail. An instrument operator, computer, and two rodmen-tapemen are assigned to the battery detail for the performance of survey operations. There are insufficient battery survey personnel for the organization of a complete survey party. However, if the battery survey control point is located near the position area, the battery survey personnel are capable of performing a short traverse to locate the battery center and to establish orienting lines.

c. 8-inch Howitzer Battery. The survey capability of the 8-inch howitzer battery is the same as that of the 105-mm howitzer battery. The battery survey personnel perform the survey operations necessary to extend control from the battery survey control point to the position area for the location of the battery center and the establishment of orienting lines. Under certain tactical conditions, it may be desirable to locate each howitzer position and to establish an orienting line for each position. In the event that the battery is operating as a battery (-) and a separate platoon, it may be necessary for the headquarters exercising operational control to provide survey assistance to one or both of the installations.

d. 762-mm Rocket Battery. The survey organization of 762-mm rocket battery is identical to that of the 105-mm howitzer battery. The battery survey section performs the survey operations necessary to extend control from the battery survey control point to each launching site and wind set location, and to establish orienting lines at these locations. Inasmuch as the rocket battery will normally be employed directly under division artillery control,

consideration must be given to the timely establishment of survey control in the rocket battery area by the division artillery survey section.

39. Survey Accuracy

Survey operations of field artillery units organic or attached to the infantry division are performed to the following minimum prescribed accuracies.

- a.* Division artillery to a prescribed accuracy of 1:3,000.
- b.* Field artillery battalions to a prescribed accuracy of 1:1,000.
- c.* Field artillery batteries possessing an atomic delivery capability to a prescribed accuracy of 1:1,000.
- d.* Field artillery batteries not possessing an atomic delivery capability to a prescribed accuracy of 1:500.

CHAPTER 5

FIRE SUPPORT PLANNING

Section I. COORDINATION

40. General

Through the maneuver of supporting fires, the commander possesses a powerful means of influencing the course of combat. A considerable part of the division's firepower lies in its organic field artillery atomic fire support capability; this requires that the division commander and the division artillery commander devote personal attention to the planning and execution of fire support. The division commander must be constantly aware of, and the division artillery commander thoroughly familiar with, the capabilities of all of the various atomic delivery means and fire support agencies.

41. Responsibility

a. The division commander evaluates targets in terms of the mission, nature of the target, availability of atomic weapons, and specifies results desired, also contingent and limiting requirements. However, evaluation in terms of delivery capabilities, troop safety, detailed effects, and predicted condition of the target area normally requires a detailed analysis, by the staff and recommendations to the commander.

b. The division artillery commander is the fire support coordinator. Based on the division commander's concept and policies, and in conformance with the use of atomic weapons planned by G3, he prepares the fire support plan, which includes the atomic fire plan. His principal assistant in fire support coordination activities is the division artillery assistant executive officer, who represents him in fire support matters in his absence. The fire support coordinator at subordinate commands and task force is the senior artillery officer at each echelon and command. At each echelon, the fire support coordinator is responsible for the details of coordination of fire support based on the supported commander's decision, combat orders, and policies, and is responsible for the preparation of the fire support plan.

42. The Division Fire Support Coordination Center (FSCC)

a. The division fire support coordination center is the fire co-

ordination agency of the division commander in which representatives of the division and the fire support agencies work together to plan and coordinate fire support. The FSCC plans, recommends and coordinates atomic and nonatomic fires for the commander and is responsible for the detailed analysis of atomic targets.

b. Under the general staff supervision of G2, the FSCC is charged with the responsibility of insuring that all target intelligence is made available to the commander as rapidly as possible.

c. The location of the FSCC is designated by the Division Commander and is habitually located at the main command post in close proximity to the G2-G3 Sections. Procedures must provide for continuous operations during displacement.

d. The size and composition of the FSCC is determined by the division commander, and may vary to meet the needs of the situation. In the planning phase prior to an operation, the FSCC may be enlarged to expedite the handling of the mass of details involved in planning and coordination. During the exploitation phase, the FSCC may be reduced to the minimum size required to implement the detailed plans, to effect departure from the detailed plans, to meet unforeseen situations, and to engage targets of opportunity promptly. A typical division FSCC may include, in addition to the Fire Support Coordinator—

- (1) The G3 Air.
- (2) The G2 Air or his representative.
- (3) Representative of each fire support agency supporting the division.
- (4) Target intelligence personnel.
- (5) Target analysis personnel.
- (6) Other advisors as required (e.g., chemical officer).
- (7) Supporting operations and communications personnel.

43. Lower Echelon FSCC

Establishment of FSCC's at lower echelons is dependent upon the responsibilities and functions of the echelon, the tactical situation, and the desires of the commander. Normally fire support coordination functions at lower echelons are exercised informally by the personnel involved through close liaison, frequent meetings, and flexible communications.

44. The Fire Support Plan

a. Fire support planning includes the procedures and techniques involved in planning for the use of all fire support, atomic and non-atomic, available to a force, to insure that its capabilities are efficiently and effectively exploited, maximum support is obtained,

and the desires and requirements of the commander are fulfilled. Effective fire support requires continuous, detailed, concurrent planning and coordination at all echelons. The fire support requirements of the battle group, the rifle company, the tank battalion, and the cavalry squadron constitute the basis for planning.

b. The fire support plan is prepared under the supervision of the fire support coordinator, and, after approval by the supported commander, it is included in the operation order of the supported command, published as an annex thereto, or issued orally or in a written fragmentary form. This plan is the basis of the fire plans of each of the available fire support means. These fire plans are normally attached to the fire support plan as appendixes. At battle group level, the plan of fires of organic infantry weapons may also be attached to the fire support plan as an appendix.

c. The fire support plan amplifies the fire support portion of the commander's concept of operations by providing specific information and instructions relative to fire support. It includes the allocation of fire support means available to the command; information pertaining to the mission of each particular agency concerned; general instructions for the accomplishment of the mission, organization for combat, and priorities; and other instructions that may be essential for amplifying the fire support aspects of the particular situation.

d. The fire support plan annex to the division operations order will normally be a formal written document when time permits. The fire support plan annex to a battle group or similar sized task force operations order may not be, nor is it necessary to be, a formal written document. However, the fire plans of the fire support agencies are always developed in detail.

e. The format for the fire support plan is, in general, the same as that of the operations order. As a guide to the preparation of the fire support plan annex, see FM 6-20.

45. Procedure

a. Although requests for supporting fires usually are from lower to higher echelons, planning and issuing of plans for an operation are continuous and concurrent at all echelons of command. There must be timely exchange of information between the commander at division, battle group, rifle company, tank battalion, and cavalry squadron and the fire support representatives at these levels. Upon receipt of warning orders and the division commander's concept of operations, the battle group commander announces his mission and concept. His staff and unit commanders

immediately initiate the development of the plan of operations, fire support plan, and plan of fires for the organic infantry weapons.

b. The mortar battery liaison officer, as the representative of the battle group fire support coordinator (mortar battery commander), consolidates and coordinates the fire support requirements received from the battle group commander and the rifle companies and arrives at a tentative plan for fulfillment of those requirements. When necessary, he indicates additional fires which must be requested from division to provide coverage which he cannot provide from available means.

c. After approval of this tentative plan by the battle group commander, the artillery portion is used by the mortar battery commander in developing the artillery fire plan (par. 46). The air portion is used by the battle group S3 air in developing the air fire plan (par. 47). When naval gunfire is available, the naval portion is used by the naval gunfire liaison officer in developing the naval gunfire plan (par. 48).

Section II. FIRE PLANNING

46. The Artillery Fire Plan

a. The artillery fire plan, which is prepared under supervision of the mortar battery commander and approved by the battle group commander, is a directive to execute the fires contained therein. The fire plan has five component parts—a graphical portion showing the planned concentrations, a target list, marginal information which includes requests for additional fires, a schedule of fires when appropriate, and a table of groups of fires when appropriate.

b. A copy of this fire plan is forwarded to the division artillery FDC where it is coordinated and integrated into the division artillery fire plan.

c. When the division artillery commander assigns fire planning responsibilities to the field artillery battalions, the fire plan is forwarded to the division artillery FDC through the appropriate field artillery battalion.

47. The Air Fire Plan

The battle group assistant S3 air, in consultation with the fire support coordinator or his representative and the forward air controller, prepares the air fire plan in the form of a request for prearranged air missions. In preparing the plan, consideration must be given to the allocation of prearranged air support received from higher headquarters and the availability of suitable targets.

The requests for prearranged air missions received from the rifle companies are coordinated and are augmented, if required. The air support request form is prepared to show the requesting unit designation and the priority the unit assigns to the mission, the description and location of the target, the results desired, the time on target, and other pertinent information needed by the tactical air force in determining the most desirable method of attack. After approval by the battle group commander, the air fire plan (requests for prearranged air missions) is forwarded to the division G3 air. The air fire plan is issued only after confirmation of these requests has been received through the division fire support coordinator.

48. The Naval Gunfire Plan

If the Navy is providing fire support for an operation, the naval gunfire plan is prepared by the naval gunfire liaison officer (Navy officer) with the battle group. This plan is coordinated and integrated into the overall plan of fire support by the fire support coordinator. When written, the plan is issued in overlay form as an appendix to the fire support plan annex. It shows graphically the concentrations to be fired by available support ships. The plan includes a description of concentrations and a schedule of fires, and it may include the location of frontlines and boundaries. The schedule of fires serves as a directive to shore fire control parties and the naval gunfire liaison officer to request naval gunfire from available ship(s) on the targets at the time indicated in the schedule of fires. Upon approval by the battle group commander, the plan is forwarded to the naval gunfire officer (Army officer) who is working with the division fire support coordinator.

49. The Atomic Fire Plan

a. The atomic fire plan is prepared at the division artillery fire direction center. Integration of atomic fires and the plan of operations is of utmost importance. The plan of maneuver or scheme of defense may well be designed around the atomic fire plan. Nonatomic fires are not disregarded. Rather, atomic and nonatomic fires complement each other to insure maximum effect.

b. The atomic fire plan must include, as a minimum, the--

- (1) Location of ground zero.
- (2) Type of yield of weapon.
- (3) Delivery means.
- (4) Time of burst.
- (5) Height of burst.
- (6) Atomic safety line.
- (7) Safety measures to be instituted by friendly troops.

c. The division G3 performs a preliminary target analysis to determine the feasibility of atomic fires on a particular target in relation to the mission of the division. Detailed target analysis is accomplished in the division FSCC.

d. At battle group level, atomic fire planning is limited to those atomic fires allocated to the battle group or consideration of atomic fires scheduled by division for delivery in the battle group sector. Requests for atomic fires may be forwarded to the division commander by the battle group commander. However, operations plans are not finalized based on the requested atomic fires until the request has been approved. Even though atomic fires have been allocated to a battle group, detailed target analysis and final coordination is accomplished at the division FSCC.

50. Action by the Division Fire Support Coordinator

a. Fire plans (artillery, air, naval gunfire) are reviewed upon receipt by the division fire support coordinator to insure that—

- (1) Atomic and nonatomic fires are fully coordinated.
- (2) Unnecessary duplication of fires is eliminated.
- (3) The plans of the various fire support agencies are coordinated.
- (4) Adequate fires are planned for targets and critical areas.
- (5) Troop safety criteria are met.
- (6) Maximum effective use is being made of fire support means.
- (7) The plans can be implemented with the fire support means available to the division.

b. If the fire plans cannot be implemented with the fire support means available to the division, additional means are requested or modifications are effected in the plans.

51. Fire Planning In Support of Task Forces

a. The procedures and techniques involved in fire planning for a task force are the same as for the battle group as outlined herein and in FM 6-18.

b. The senior artillery commander with the task force is the fire support coordinator. The task force fire support plan, if written, and fire plans are forwarded to the fire support coordinator at the next higher echelon for coordination and further implementation, if appropriate.

c. When atomic fires have been allocated to a task force and a delivery means has been attached, special weapons qualified personnel must be included in the task force organization to accomplish the required detailed target analysis.

CHAPTER 6

COMMUNICATIONS

52. General

a. Effective artillery support depends on efficient communication. The communication to be established in any situation is a command decision, based on the tactical situation, the facilities available, and the commander's estimate of the requirements.

b. All means of communication will be utilized as required. No means is considered primary.

c. The division signal battalion will install and operate a division area communication system of multichannel radio relay and field cable. This system is not intended to replace the separate functional wire and radio systems of the artillery. Artillery units will use the division area communication system for administrative communication on a common user basis. In addition, artillery units will be allocated sole-user channels for operational and fire direction communication where communication requirements exceed the artillery's organic capability and during periods when the organic communication is disrupted. A detailed discussion of division communication systems is contained in FM 11-10.

d. A variable communication organization for combat is illustrated in paragraphs 53 through 55 and figures 13 through 25. Reference to battalion refers to the battalion headquarters exercising operational control of the battery.

e. For a discussion of the principles of artillery communication see FM 6-20.

53. Requirements

The communication requirements are based on the mission of the unit as discussed in FM 6-20 and this manual.

54. Wire

a. General. Wire for fire direction and limited command is installed prior to or during occupation of position. The system is expanded as time and personnel are available. As more time becomes available the wire system will be extended, duplicated, and improved to meet the maximum requirement.

b. Division Artillery Headquarters.

- (1) The division signal battalion will establish a terminal station(s) of the division area communications system in the vicinity of the division artillery command post (CP).

In a type situation, these stations will afford 12 channels to the division advance (tactical) CP and when possible 12 channels to the division main CP. Sole-user circuits must be provided to the division artillery liaison officer at the division CP.

- (2) When the situation dictates, sole-user circuits to subordinate units should be established through the division area communication system for fire direction and operational messages. Administrative messages to subordinate units should be handled through the division system on a common user basis.
- (3) Wire communication with corps artillery will be over lines established by the corps artillery or through the division and army (corps) area communication systems. One sole-user circuit is required from corps artillery FDC to division artillery FDC.
- (4) A type wire system for division artillery is shown in figure 13.

c. 105-mm Howitzer Battalion and Composite Battalion Headquarters.

- (1) The concept of operation of the 105-mm howitzer battalion and composite battalion headquarters places similar communication requirements on both units.
- (2) The battalion will enter the division area communication system through the nearest communication center.
- (3) A type wire system for battalion is shown in figure 14.

d. 155-mm and 8-inch Howitzer Batteries.

- (1) The 155-mm and 8-inch howitzer batteries have similar communication requirements.
- (2) Type wire systems for 155-mm and 8-inch howitzer batteries are shown in figures 15 and 16, respectively.

e. 762-mm Rocket Battery. A type wire system for a 762-mm rocket battery is shown in figure 17.

f. 105-mm Howitzer Battery.

- (1) When the 105-mm howitzer battery is reinforcing a mortar battery, requests for fire will be received over the line to the mortar battery or through the division area communication system.
- (2) The battery will enter the division area communication system through the nearest communication center.
- (3) A type wire system for a 105-mm howitzer battery is shown in figure 18. In situations requiring the battery to operate in two echelons, e.g., during displacement, similar installations will be required in both positions.

55. Radio

All units will maintain listening watch on the division warning net for warnings and intelligence information disseminated on a broadcast basis. As required for control of survey parties and transmission of survey data, all units will use a common corps artillery survey frequency.

a. Aircraft of the division aviation company flying surveillance under division artillery control will use the division artillery command and fire direction net. When artillery fire is being adjusted, the division artillery FDO will direct the aircraft to the frequency of the battalion or battery which will fire the mission. When air-

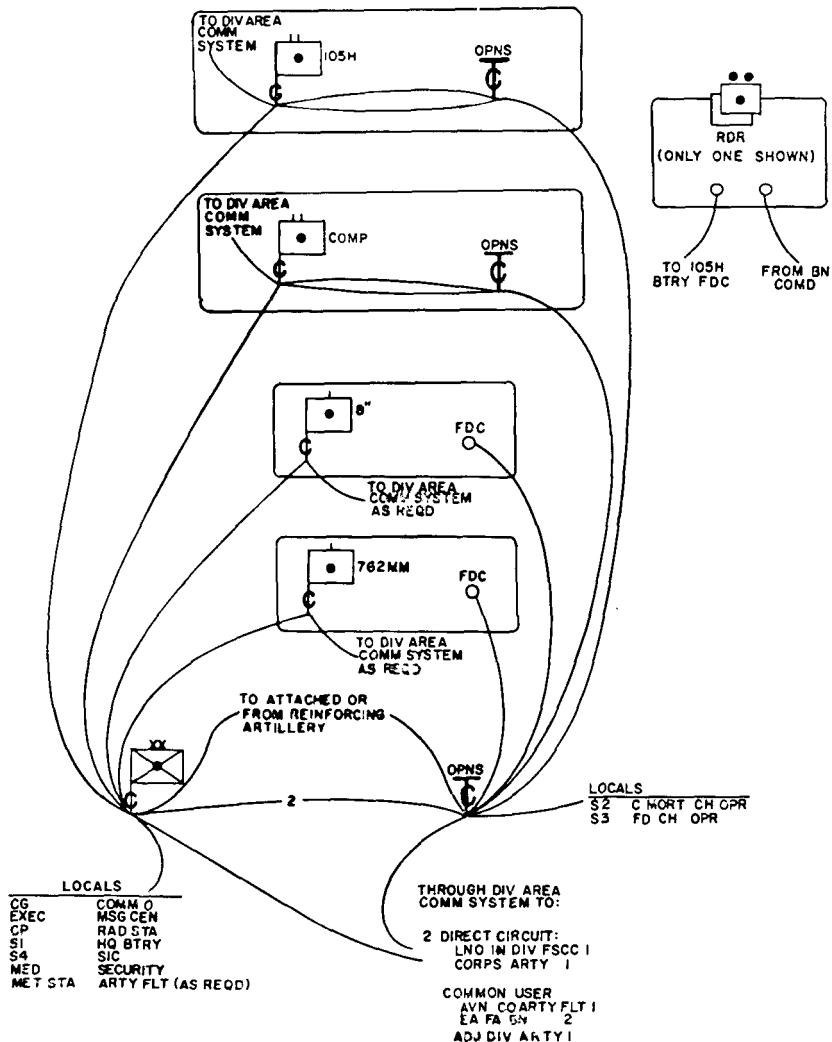

Figure 13. Type wire system, division artillery.

craft are assigned specific missions under battalion or battery control, they will utilize a frequency of the battalion or battery.

b. Division artillery headquarters will operate three internal radio nets—a command and intelligence net, AM; a fire direction net, AM; and a command and fire direction net, FM. Division artillery headquarters maintains listening watch on the division

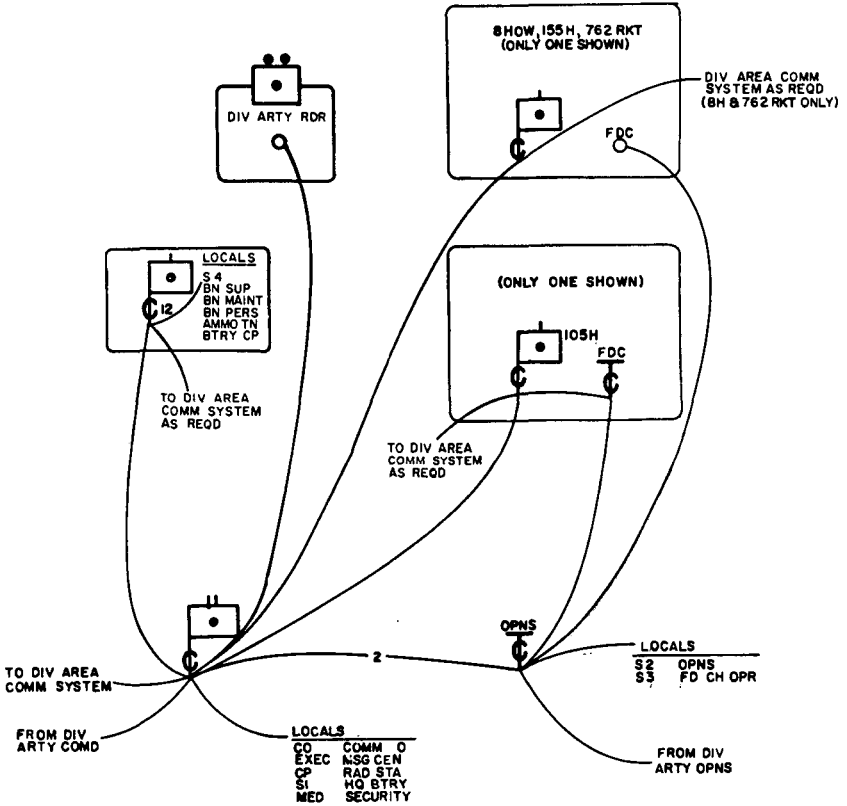

Figure 14. Type wire system, field artillery battalion.

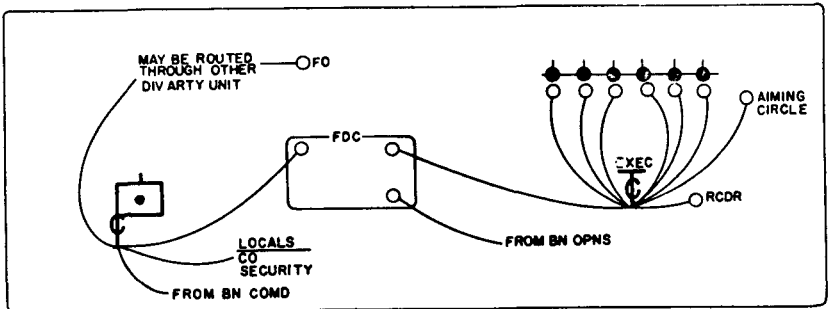

Figure 15. Type wire system, 155-mm howitzer battery.

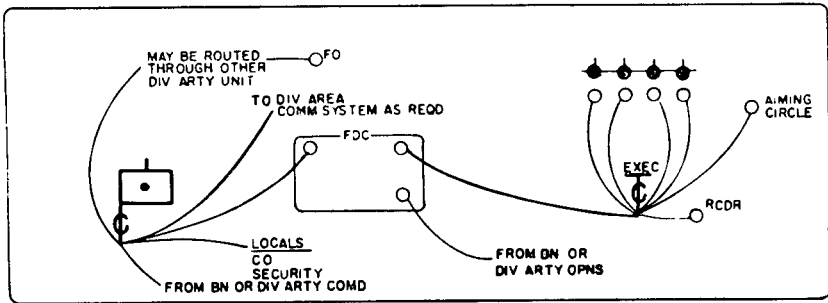

Figure 16. Type wire system, 8-inch howitzer battery.

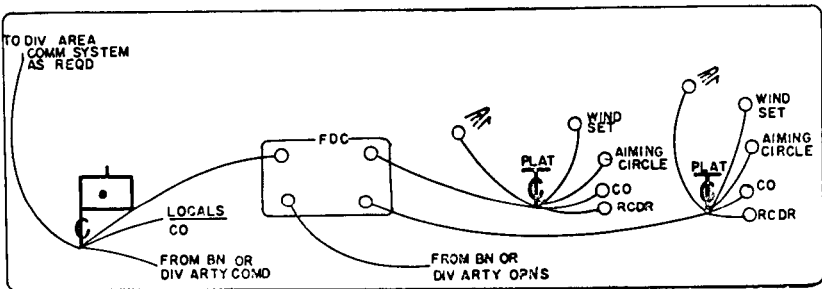

Figure 17. Type wire system, 76.2-mm rocket battery.

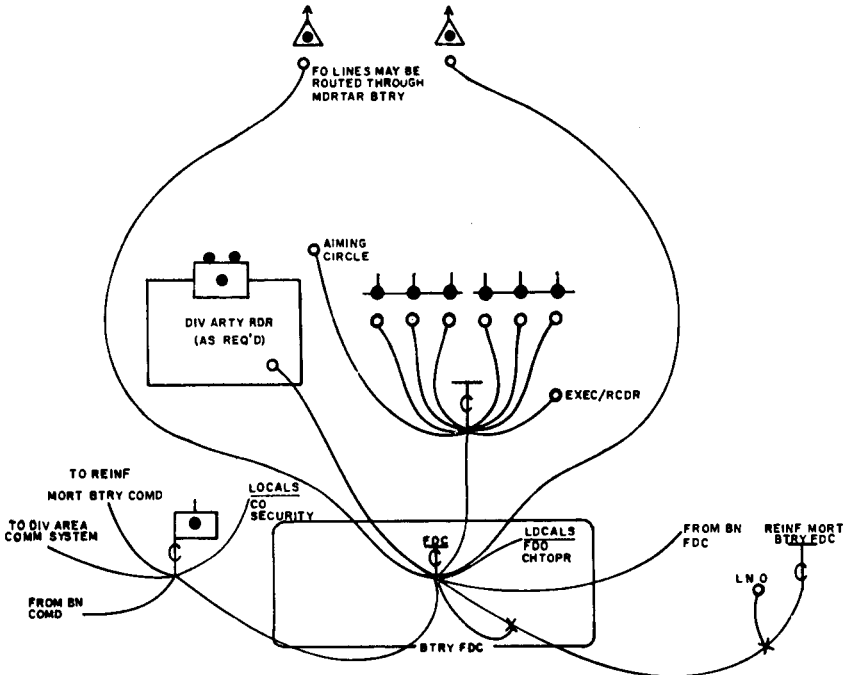

Figure 18. Type wire system, 105-mm howitzer battery.

warning net and the corps artillery antiaircraft intelligence net. Air defense warnings applicable to the division received over the corps AAA intelligence net are rebroadcast by division artillery over the division warning net. Type radio nets for division artillery are shown in figure 19.

- (1) The command and intelligence net, operating radioteletype (RATT), will be used for control of the battalions and for transmission of target information. When traffic load permits, this net may be used for administrative traffic.
- (2) The fire direction net will be used for transmission of fire requests from battalion to division artillery, fire missions from division artillery to battalion or batteries retained under its control, time on target missions to all batteries, and met messages to all batteries. Met messages and time on target missions must be by voice transmission; other messages may be by RATT.
- (3) The command and fire direction net is primarily used for communication between elements of the headquarters and for communication with airborne aircraft. It may, when distance permits, be used for communication with subordinate units.

c. Each 105-mm howitzer or composite battalion headquarters operates three internal FM radio nets—a command net, a primary fire direction net, and an alternate fire direction net. Type radio nets for a 105-mm howitzer or composite battalion are shown in figure 20.

- (1) The command net is used for control of subordinate units.
- (2) The primary fire direction net is used for transmission of fire requests from battery to battalion, fire missions from battalion to battery, time on target missions to all batteries, coordination of the massed fires of the battalion and reinforced mortar batteries, and communication with the observer adjusting fire from an airborne aircraft.
- (3) The alternate fire direction net is used by the 105-mm howitzer batteries when firing simultaneous missions and as alternate communication to the mortar batteries of the battle groups. This net is also used as a fire direction net by the observers of the 155-mm howitzer batteries.

d. The 155-mm howitzer batteries will use the FM command (command and fire direction) net of the headquarters controlling their fires as a battery command net. When the batteries are under battalion control, the battalion alternate fire direction net is used as a fire direction net. Type radio nets are shown in figure 21.

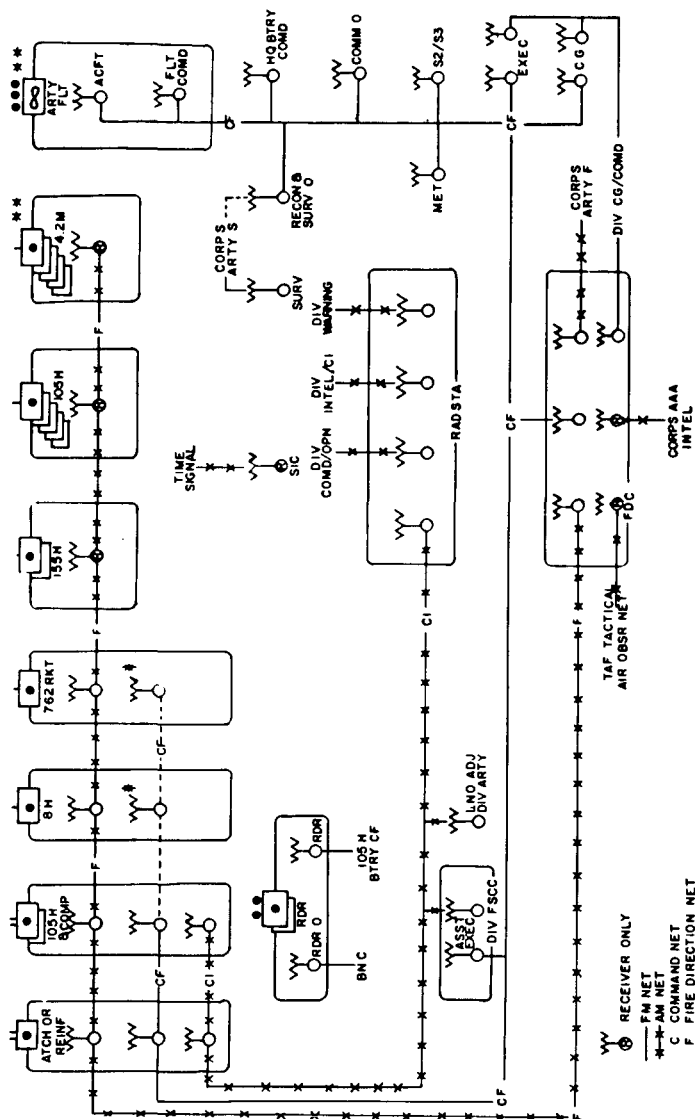

- ⊕ RECEIVER ONLY
- ⊕ FM NET
- ⊕ AM NET
- ⊕ COMMAND NET
- ⊕ FIRE DIRECTION NET
- ⊕ INTELLIGENCE NET
- ⊕ SURVEY NET
- ⊕ WHEN OPR UNDER DIV ARTY CONTROL
- ALTERNATE EMPLOYMENT
- ** NOT ORGANIC TO DIV ARTY

Figure 19. Type radio system, division artillery.

e. The 8-inch howitzer and 762-mm rocket batteries each operate one internal FM command and fire direction net. Type radio nets are shown in figures 22 and 23.

f. The 105-mm howitzer battery operates an internal FM command and fire direction net. When firing simultaneous missions, the battery may use the battalion alternate fire direction net for one mission. For a type radio system for the 105-mm howitzer, see figure 24.

- (1) The battery operates in the reinforced mortar battery fire direction net to receive requests for fire from the mortar battery. When attached to a mortar battery, the 105-mm howitzer battery operates in the mortar battery command and FD nets. When assigned a mission of reinforcing a mortar battery, the 105-mm howitzer battery operates in the mortar battery command and FD nets but maintains radio contact with the next higher artillery headquarters. When assigned a mission of general support, reinforcing the fires of a mortar battery, the 105-mm howitzer battery operates in the mortar bat-

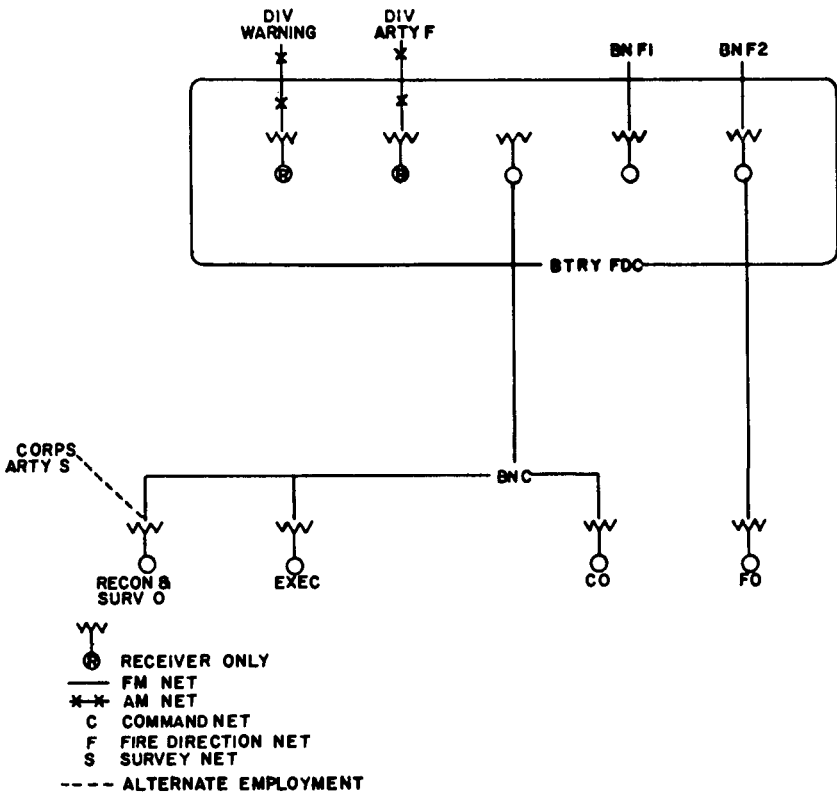

Figure 21. Type radio system, 155-mm howitzer battery.

tery FD net and in the nets of the appropriate artillery battalion.

- (2) At times when the howitzer battery is required to operate in two positions, e.g., during a displacement by echelon, the communication requirements are more extensive than shown in figure 24. However, this system can be readily modified by using personnel and equipment available within the battery.

g. Artillery elements of the division furnish certain equipment for use by the air liaison officer and the forward air controllers. Each mortar battery furnishes a radio set for a forward air controller. Division artillery headquarters and headquarters battery furnishes two vehicles with appropriate radio equipment for the tactical air force air liaison officer (ALO). These vehicles are

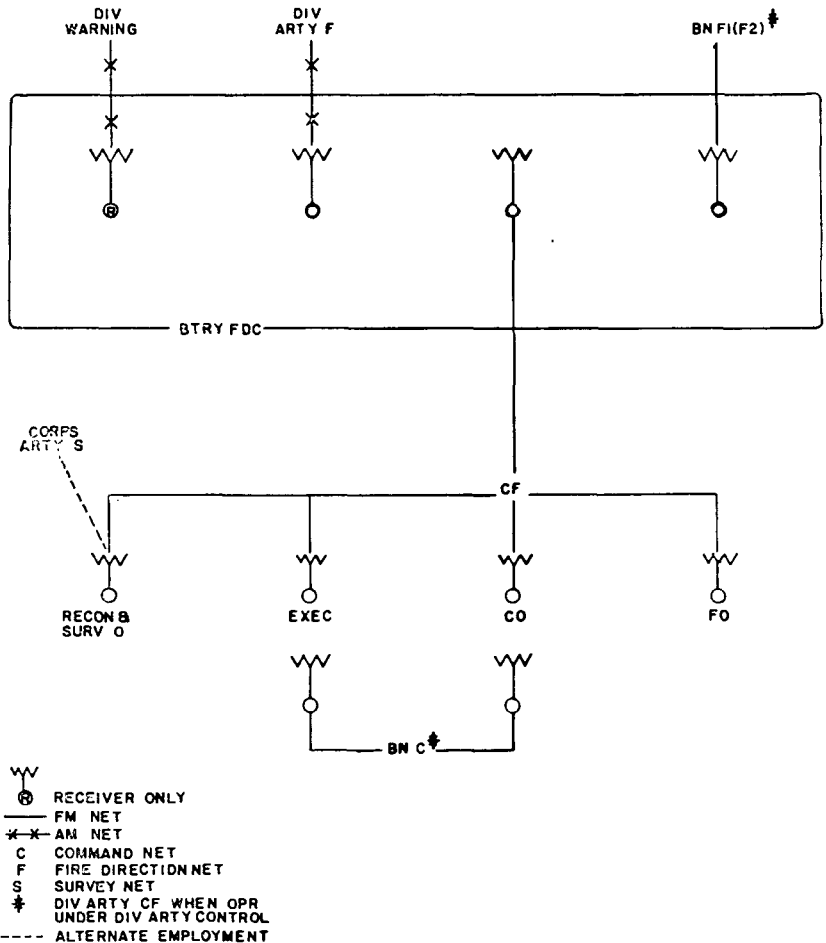

Figure 22. Type radio system, 8-inch howitzer battery.

AM-FM retransmission stations to assure communication between forward air controllers and the air liaison officer. Retransmission stations will be positioned well forward within FM range of the forward air controllers. Division artillery headquarters and headquarters battery also furnishes one vehicle for a forward air controller. A type radio system for employment of these sets is shown in figure 25.

56. Procedure

a. The short-phrase repeat-back method of communication transmission described in Joint Army-Navy-Air Force publication (JANAP) 164 may be modified for greater speed when stable communication permits.

b. A different call word will be assigned to division artillery; each battalion headquarters, and each field artillery battery. To

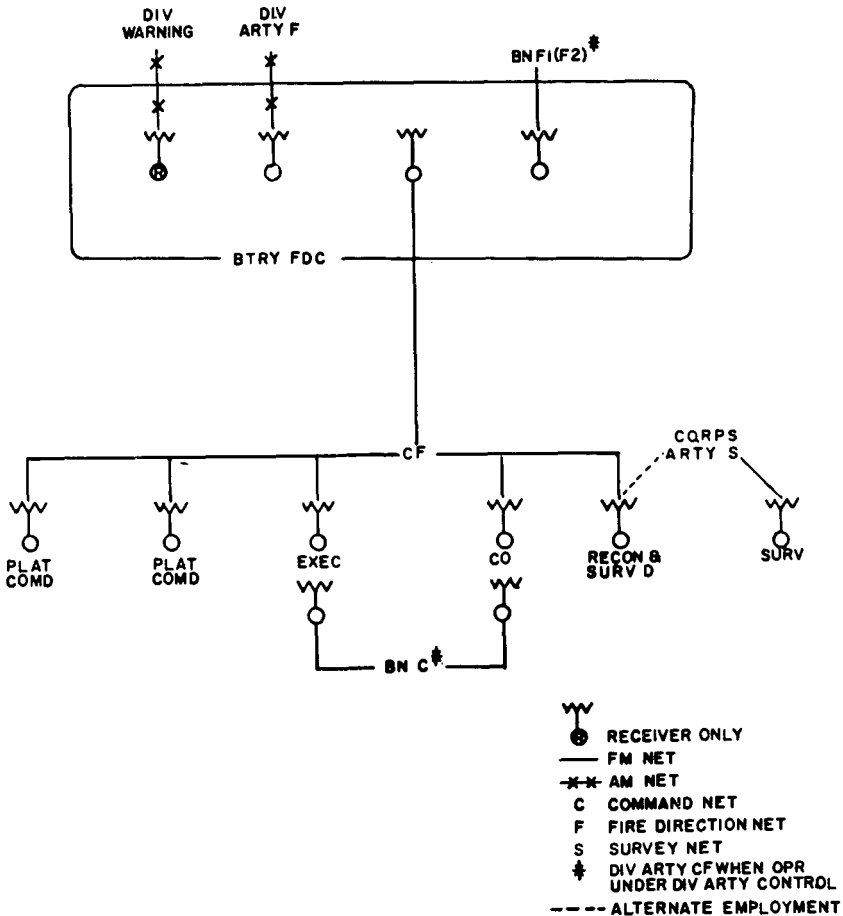

Figure 23. Type radio system, 762-mm rocket battery.

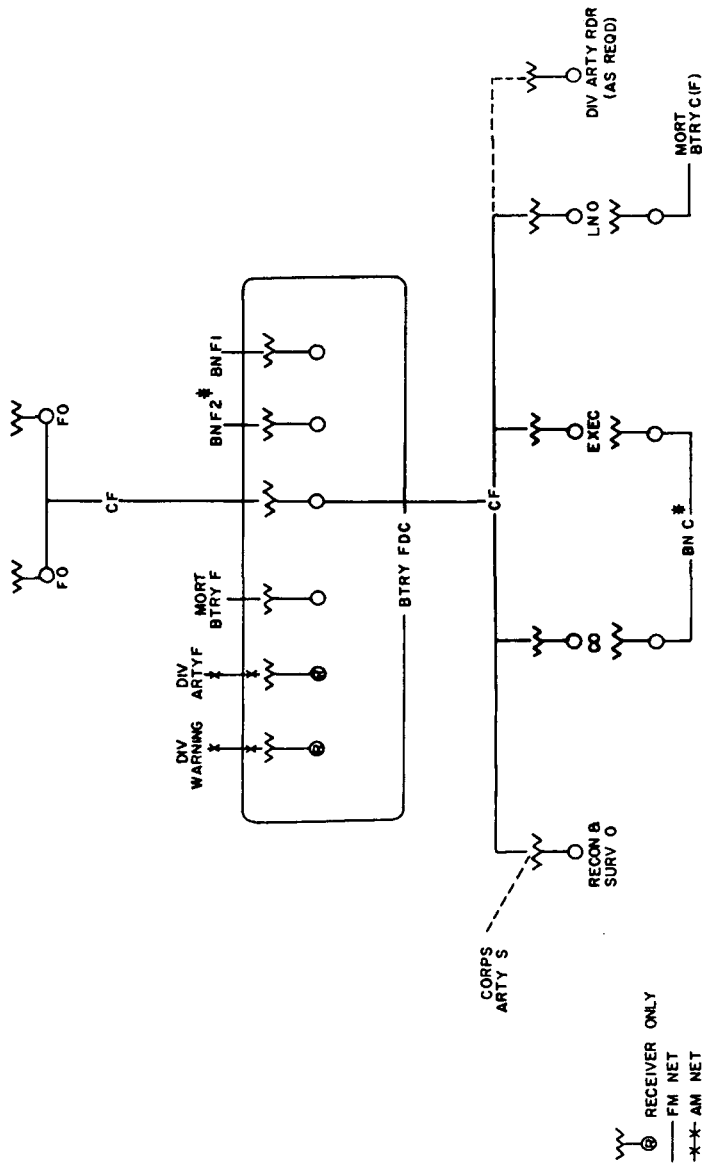

Figure 24. Type radio system, 105-mm howitzer battery.

facilitate processing fire missions between observer and FDC and between FDC's, a standardized list of suffix numbers should be used to identify fire direction installations regardless of the transmission means employed.

c. Voice procedure for processing type fire missions is shown in FM 6-40.

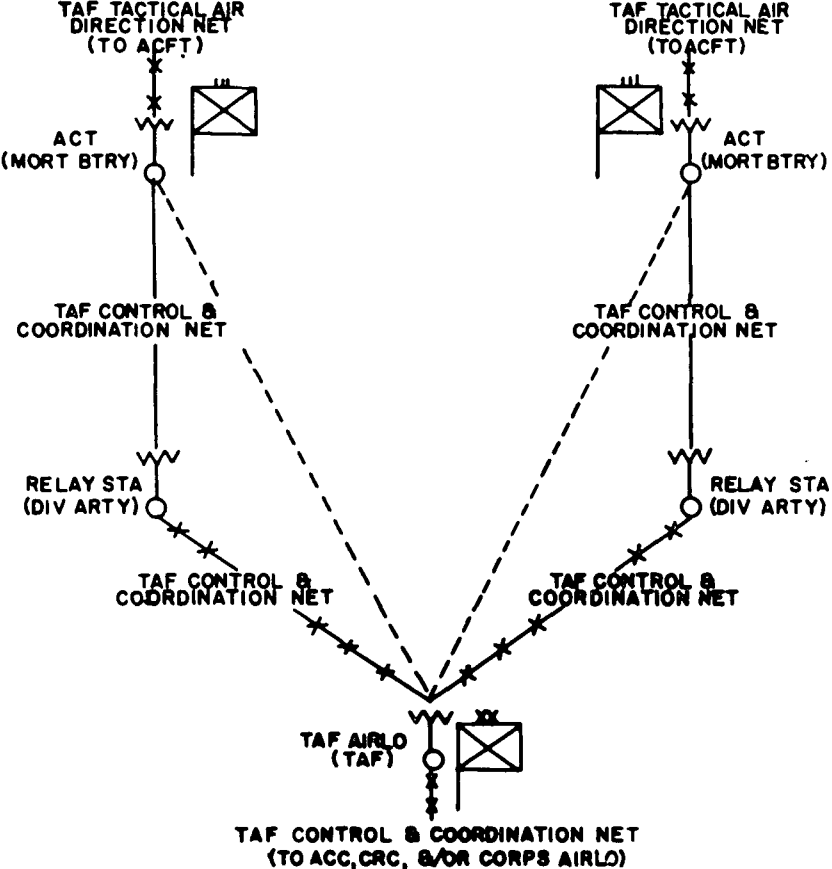

Figure 25. Type radio system for coordination and control of close air support.

CHAPTER 7

GUNNERY

57. General

The definitions, objectives, techniques, and doctrines of gunnery as covered in FM 6-40 (for cannon type units) and in FM 6-61 (for the 762-mm rocket) are applicable as modified by this chapter.

58. Command

a. Artillery headquarters coordinate the fires of their subordinate units and may allocate reinforcing artillery fires in order to further the plan of the force commander. Because of the several types of units in division artillery, the detailed procedures of battery fire direction will vary according to the type of weapon and the situation.

- (1) The FDC organization and procedures for all cannon type units are as outlined in FM 6-40, with exceptions or modifications shown in this chapter.
- (2) The FDC organization and procedures for the 762-mm rocket battery are as outlined in FM 6-61, and FM 6-61A.
- (3) When operating as an independent battery, the battery FDC performs operations previously considered appropriate in the battalion FDC. Platoon FDC's are employed during displacement or other occasions when required (fig. 26).

b. The battery executive (platoon executive) commands the firing battery (platoon) and is responsible for controlling the firing of the weapons and for all operations of the firing battery (platoon). The battery (platoon) FDO is in charge of the battery (platoon, when applicable) fire direction center.

c. The procedure for processing fire requests and the pertinent points which must be considered prior to attacking a target are as stated in FM 6-40 and FM 6-61.

59. Control

a. The FDC personnel at division artillery control and direct the fires of the units over which they exercise centralized control. Firing data are not normally prepared at division artillery FDC unless elements of the FDC's of the firing units are attached to it for special missions. When control is centralized, the division artillery FDO makes the decision to fire and issues the fire order.

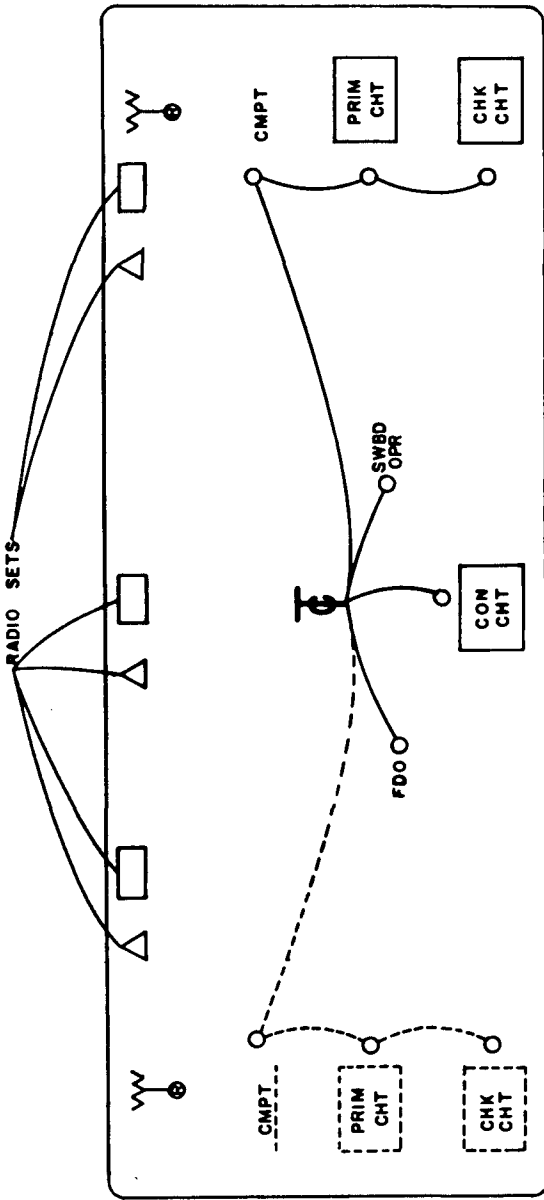

- TELEPHONE SET WITH HANDSET - HEADSET
- VOICE REMOTE CONTROL
- △ EXTENDED SPEAKER
- vw PORTABLE AM RADIO RECEIVER
- ⋯ REQUIRED IN BATTERY FDC ONLY WHEN PLAT LAID ON WIDELY DIVERGENT AZIMUTH. UTILIZED AT PLAT FDC WHEN ONE PLAT AT SEPERATE POSITION (PLAT CONTACTS AS FDO)

Figure 26. Type battery fire direction center, 105-mm howitzer battery.

b. The FDC personnel at battalion likewise control and direct the fires of units over which they exercise centralized control. Firing data can be originated and/or checked at battalion FDC when elements of the subordinate FDC's have been attached. When control is centralized, the battalion FDO makes the decision to fire and issues the fire order. When control is decentralized to the battery (platoon), the battery FDO (platoon FDO) performs the same duties as the battalion FDO.

60. Production of Firing Data

a. Firing data are primarily determined in the FDC of all artillery batteries or platoons.

b. In batteries which are not organized in platoons, the battery FDC personnel plot the target and convert the fire request and the fire order into appropriate commands for transmission to the battery executive. In batteries which are organized in platoons, the platoon FDC personnel perform the same functions as the battery FDC personnel.

61. Fire Direction Personnel

The duties and functions of fire direction personnel are as outlined in FM 6-40 (cannon type units) or FM 6-61 (rockets). When a platoon FDC is operational, the platoon commander is the platoon FDO.

62. Fire Direction Procedures

The personnel of the fire direction center are assigned specific duties and follow fire direction procedures as outlined in FM 6-40 or FM 6-61. Minor modifications not covered in these manuals are—

a. One of the battery check charts is designated as a master chart for the sole purpose of standardizing all firing charts.

b. In batteries which are deployed as firing platoons, one of the platoon charts (primary or check chart) should be located at the battery FDC. When the platoon is operating independent of the battery, both charts are located at the platoon.

CHAPTER 8

ADMINISTRATION

63. General

When a field artillery unit is attached to other than an artillery organization, the commander of the organization to which attached is responsible for normal administrative support of the artillery unit. When a field artillery unit is attached to or placed under the operational control of another field artillery organization the administrative procedures outlined herein apply.

64. Personnel

Division artillery headquarters and field artillery battalion headquarters retain normal administration responsibility for organic batteries. The parent battalion headquarters is the office of record for all matters pertaining to its organic batteries regardless of division artillery organization for combat or location of the batteries within the division area.

65. Supply

Supply and resupply (except ammunition) within the infantry division will be accomplished by either supply point or unit distribution, which ever is deemed appropriate under the tactical situation. When unit distribution is used, distribution will be made to battle group, battalion and separate company level by using transportation of the quartermaster company and the transportation battalion.

a. The field artillery battalion is responsible for classes II and IV supply to organic batteries regardless of division artillery organization for combat or the location of the batteries within the division area.

b. The battalion headquarters exercising operational control over field artillery batteries, as specified by the division artillery organization for combat, is responsible for classes I, III, and V supplies to those batteries.

c. When a battery is operating directly under the operational control of division artillery, the parent battalion is responsible for all supplies for the battery except ammunition.

66. Ammunition

The ammunition train of each field artillery battalion is organ-

ized to permit designation of a specific ammunition section to work with each organic battery. Ammunition resupply is by normal supply point distribution by using transportation organic to the using unit.

a. When a battery is operating under the operational control of other than its parent battalion, its designated ammunition section will be attached to the ammunition train of the controlling battalion.

b. When a battery is operating under the operational control of division artillery, its designated ammunition section will be attached to the battery and ammunition resupply becomes the responsibility of division artillery.

67. Maintenance

Artillery commanders at all echelons are responsible for first-echelon maintenance of all organic equipment. Each battery is capable of performing limited second-echelon maintenance, and each battalion is responsible for normal second-echelon maintenance. The parent battalion is responsible for routine maintenance functions of its organic batteries regardless of the status of the battery within the division organization for combat or the location within the division area.

68. Mess

Mess personnel and equipment, except transportation, are organic to the battery headquarters of each battery in the field artillery battalions. Transportation for each battery's mess is furnished by the supply section of the parent battalion's service battery.

69. Transportation

The units of division artillery are not 100 percent mobile for tactical movement. When the division is employed in a moving situation, division artillery must be augmented with transportation from a higher echelon in order to accomplish simultaneous movement of units and resupply functions.

FM 7-100	The Infantry Division (when published).
FM 11-10	Signal Battalion, Infantry Division (when published).
FM 17-1	Armor Operations (when published).
FM 21-5	Military Training.
FM 21-6	Techniques of Military Instruction.
FM 21-26	Map Reading.
FM 21-30	Military Symbols.
FM 30-5	Combat Intelligence.
FM 30-7	Combat Intelligence, Regiment, Combat Command, and Smaller Units.
FM 31-15	Operations Against Airborne Attack, Guerilla Action, and Infiltration.
FM 57-20	Airborne Techniques for Divisional Units.
FM 57-30	Airborne Operations.
(O) FM 101-5	Staff Officers Field Manual: Staff Organization and Procedure.
TM 6-200	Artillery Survey.
TM 6-242	Meteorology for Artillery.
(S) TM 39-0-1	Numerical Index to Joint Special Weapons Publications (U).
TM 57-210	Air Movement of Troops and Equipment.

APPENDIX II

COMMON NUMBERING SYSTEM FOR CONCENTRATIONS

1. First Letter Designation

The first letter of the concentration designation indicates the division. This letter is assigned to division by higher headquarters.

2. Second Letter Designation

The second letter of the concentration designation will be as follows:

<i>Unit</i>	<i>Second Letter</i>
1st Battle Group	A
2d Battle Group	B
3d Battle Group	C
4th Battle Group	D
5th Battle Group	E
1st How Bn	F
Battery A (105-mm how)	G
Battery B (105-mm how)	H
Battery C (105-mm how)	I
Battery D (105-mm how)	J
Battery E (105-mm how)	K
2d FA Bn	L
Battery F (155-mm how)	M
Battery G (155-mm how)	N
Battery H (8-inch how)	O
Battery I (762-mm rkt)	P
Division artillery	Q
Air	R
Naval	S
Attached units	T, U, V, etc., as assigned by division.

3. Battle Group Concentration Numbers

Concentration numbers within a battle group will be assigned as follows:

<i>Unit</i>	<i>Numbers</i>
Battle group	000-099
Company A	100-199
Company B	200-299
Company C	300-399
Company D	400-499
Mortar battery	500-699
Attached units or as desired	700-999

4. Examples

a. The number CA 534 would be assigned to a concentration by the mortar battery of the 1st Battle Group of the division designated by the letter C.

b. The number CD 104 would be assigned to a concentration by Company A of the 4th Battle Group of the division designated by the letter C.

c. The number BO 236 would be assigned to a concentration by the 8-inch howitzer battery of the division designated by the letter B.

INDEX

	Paragraphs	Page
Accuracy, surgey	39	30
Administration, general	63	53
Air fire plan	33	27
Air observation	47	34
Air photography	33	27
Air warning	55	39
Ammunition	66	53
Antiaircraft artillery	22	23
Appendixes to fire support plan	44	32
Army aviation	23-26	23-24
Artillery fire plan	46	34
Atomic fire plan	49	35
Attachment:		
Antiaircraft artillery	22	23
Field artillery	18	18
Aviation, army	23-26	23-24
Base, target area	32, 35	26, 27
Battalion commanders, duties	9	14
Battery commanders, duties	10	14
Battery group	18	18
Centralized control	59	50
Charts, fire direction	62	52
Check chart	62	52
Combat, organization	15-19	17-19
Command:		
Army aviation	25	23
Responsibility	8-10, 58	12-14, 50
Common control	35	27
Communication:		
Close air support	55	39
Radio	55	39
Voice procedure	56	47
Wire	54	37
Concentration numbering system	app II	57
Control:		
Army aviation	24	23
Fire	59	50
Survey	35	27
Data, firing	60	52
Direct support mission	17, 18	18
Displacement	16	17
Duties:		
Artillery flight commander	12	15
Battalion commanders	9	14
Battery commanders	10	14
Division artillery assistant executive	8	12

	Paragraphs	Page
Division artillery commander.....	8	12
Division artillery executive.....	8	12
Duties—Continued		
Fire direction officer.....	8, 58-59	12, 50
Fire direction personnel.....	58-61	50-52
Employment, tactical.....	13-26	16-24
Examples organization for combat.....	19	19
Fire direction center:		
Battalion.....	59	50
Battery.....	58, 59	50
Division artillery.....	43, 59	32, 50
Platoon.....	58-62	50-52
Fire direction:		
Personnel.....	59, 61	50, 52
Procedures.....	62	52
Fire plans:		
Air fire plan.....	47	34
Artillery fire plan.....	46	34
Atomic fire plan.....	49	35
Naval gunfire plan.....	48	35
Fire planning:		
For task forces.....	51	36
Procedure.....	45	33
Fire support coordinator:		
Division.....	41	31
Battle group.....	45	33
Task force.....	51	36
Fire support:		
Annex.....	44	32
Coordinator.....	41, 45, 51	31, 33, 36
Plan.....	44	32
Responsibilities.....	41	31
Firing data.....	60	52
FSCC.....	42, 43	31, 32
Gunnery.....	57-62	50-52
G2.....	42	31
G3.....	41	31
G3 air.....	43, 47	32, 34
Howitzer batteries.....	6, 16, 38	5, 17, 29
Intelligence:		
Agencies.....	29	25
General.....	27	25
Personnel.....	28	25
Location of:		
Fire direction charts.....	62	52
Radar.....	32	26
Survey control points.....	35-38	27-29
Maintenance.....	67	54
Master chart.....	62	52

	Paragraphs	Page
Mess	68	54
Meteorology	30	26
Missions:		
Army aviation	26	24
Tactical	17, 18	18
Mortar batteries	18	18
Naval gunfire:		
Officer	43, 45, 48	32, 33, 35
Plan	48	35
Observation:		
Air	33	27
General	31	26
Ground	32	26
Posts	32	26
Operations order	19	19
Organization:		
For combat	15-19	17-19
Of units	3-6	3-5
Orienting line	38	29
Passive air defense	22	23
Personnel:		
Administration	64	53
Fire direction	59, 61	50, 52
Survey	35-38	27-29
Photography, air	33	27
Planning:		
Fire	46-51	34-36
Fire support	44	32
Survey	35	27
Platoon employment	16	17
Positions:		
Alternate	35	27
Radar	32	26
Supplementary	35	27
Prearranged air requests	47	34
Primary chart	62	52
Radar	32	26
Radio communications	55	39
References	app I	55
Rocket battery, 762-mm	6, 16, 38	5, 17, 29
S3 air	45, 47	33, 34
Safety measures	41, 49	31, 35
Security:		
Against ground attack	21	22
Against air attack	22	23
For atomic delivery elements	21	22
Special considerations	14	16
Staff, division artillery	7	12
Supply	65	53

	Paragraphs	Page
Survey:		
Accuracies	39	30
General	34	27
Operations	36-38	28-29
Personnel	36-38	28-29
Planning	35	27
Tactical missions	17	18
Target area base	32, 35	26, 27
Target:		
Acquisition	27, 29	25
Analysis	41, 42	31
Information	49, 51	35, 36
Information	27, 29, 42	25, 31
Task forces:		
Fire planning	51	36
Organization	18	18
Transportation	69	54
Warning, air	55	39
Wire communication	54	37

[AG 353 (5 Aug 57)]

By Order of *Wilber M. Brucker*, Secretary of the Army:

MAXWELL D. TAYLOR,
General, United States Army,
Chief of Staff.

Official:

HERBERT M. JONES,
Major General, United States Army,
The Adjutant General.

DISTRIBUTION:

Active Army:

CNGB	Armies
DCSPER	Corps
ACSI	Div
DSCOPS	FA Gp
DCSLOG	Bn
USCONARC	Co
Technical Stf, DA	USMA
Technical Stf Bd	Svc Colleges
US ARADCOM	Br Svc Sch
OS Maj Comd	USATC FA
MDW	Mil Dist

NG: State AG; units—same as Active Army.

USAR: Same as Active Army.

For explanation of abbreviations used, see AR 320-50.