

U
408.3
A1
FM

S/S March 69

Reference

FM 6-162

Reference

DEPARTMENT OF THE ARMY FIELD MANUAL

RADAR SET AN/TPS-25



HEADQUARTERS, DEPARTMENT OF THE ARMY
APRIL 1962

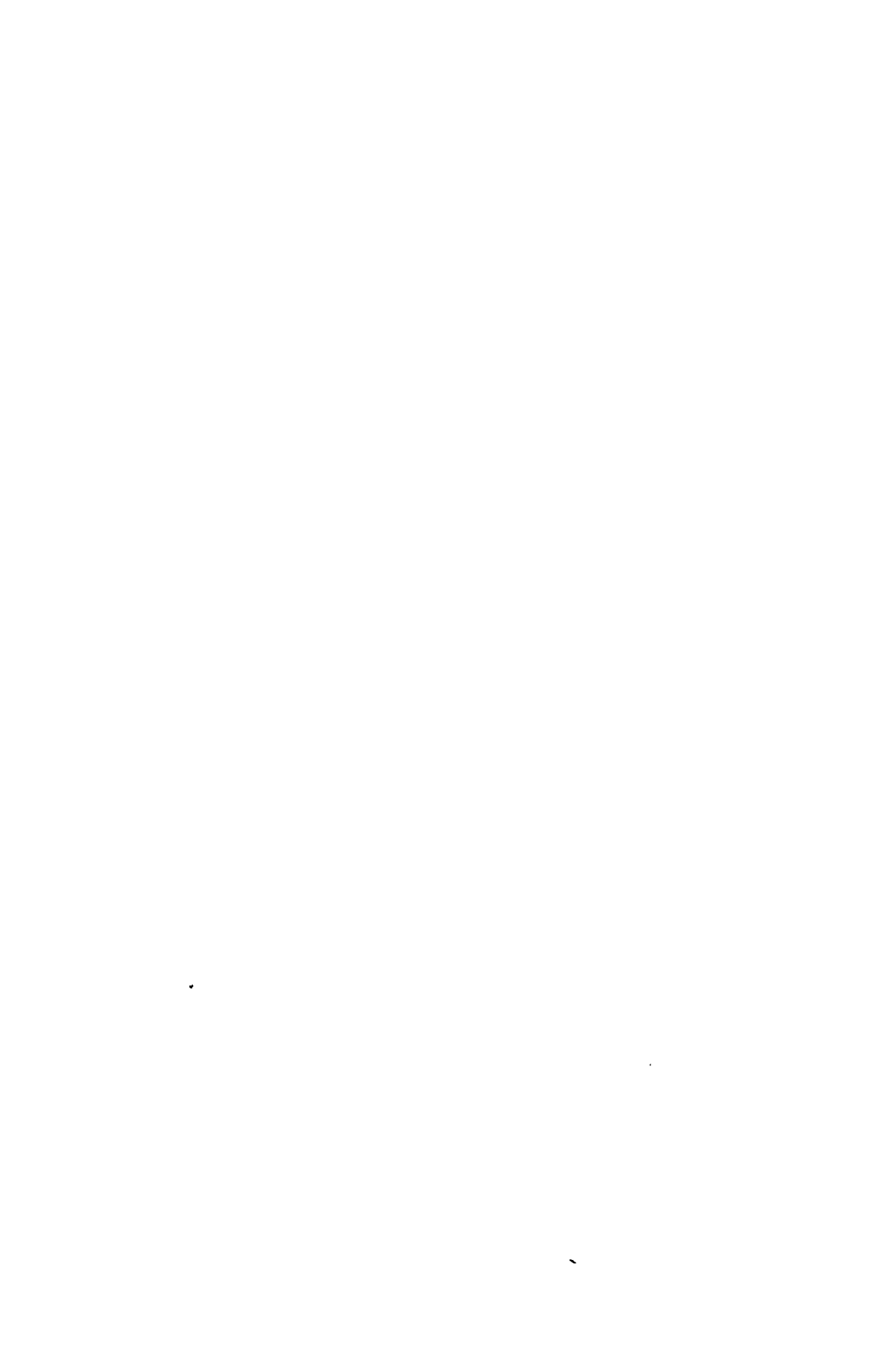

FIELD MANUAL }
 No. 6-162 }

HEADQUARTERS,
 DEPARTMENT OF THE ARMY
 WASHINGTON 25 D. C., 2 April 1962

RADAR SET AN/TPS-25

	Paragraphs	Page
CHAPTER 1. GENERAL.....	1-3	2
2. ORGANIZATION.....	4-6	4
3. TACTICAL EMPLOYMENT AND POSITION REQUIREMENTS.	7-10	6
4. EMPLACEMENT AND MARCH ORDER		
Section I. General.....	11, 12	9
II. Emplacement.....	13, 14	10
III. March order.....	15, 16	17
CHAPTER 5. PREOPERATION AND PERFORMANCE CHECKS.	17-26	19
6. BATTLEFIELD SURVEILLANCE AND MOVING GROUND TARGET DETECTION		
Section I. Personnel.....	27, 28	31
II. Battlefield surveillance and moving ground target detection.	29-32	31
CHAPTER 7. PROCEDURE FOR MINIMIZING THE EFFECT OF JAMMING.	33-37	34
8. DECONTAMINATION OF EQUIPMENT.....	38-41	42
9. DESTRUCTION OF EQUIPMENT.....	42-45	44
10. SAFETY PRECAUTIONS.....	46-48	45
11. TRAINING.....	49-52	47
APPENDIX REFERENCES.....		49
INDEX.....		51

CHAPTER 1

GENERAL

1. Purpose

This manual is a guide for the commander in developing field artillery radar sections, employing the radar set AN/TPS-25, into efficient teams.

2. Scope

a. This manual covers the organization; tactical employment; individual duties of section personnel; techniques of operation of the radar set AN/TPS-25 in accomplishing the missions of battlefield surveillance and moving target detection; antijamming procedures; decontamination and destruction of equipment; safety precautions; and section training.

b. The material presented herein is applicable, without modification, to both nuclear and nonnuclear warfare.

c. Users of this manual are encouraged to submit recommended changes or comments to improve the manual. Comments should be keyed to the specific page, paragraph, and line of text in which change is recommended. Reasons should be provided for each comment to insure understanding and complete evaluation. Comment should be forwarded direct to Commandant, U.S. Army Artillery and Missile School, Fort Sill, Okla.

3. Equipment

a. Major components of the radar set AN/TPS-25 (fig. 1) are—

- (1) *Radar set control.
- (2) *Power supply.
- (3) *Plotting board.
- (4) *Servo data coordinator.
- (5) Antenna
- (6) Receiver-transmitter.
- (7) Modulator.
- (8) Engine generator.

*Normally operated from the electrical equipment shelter S-124/G. Remaining components are removed from the shelter during operation.

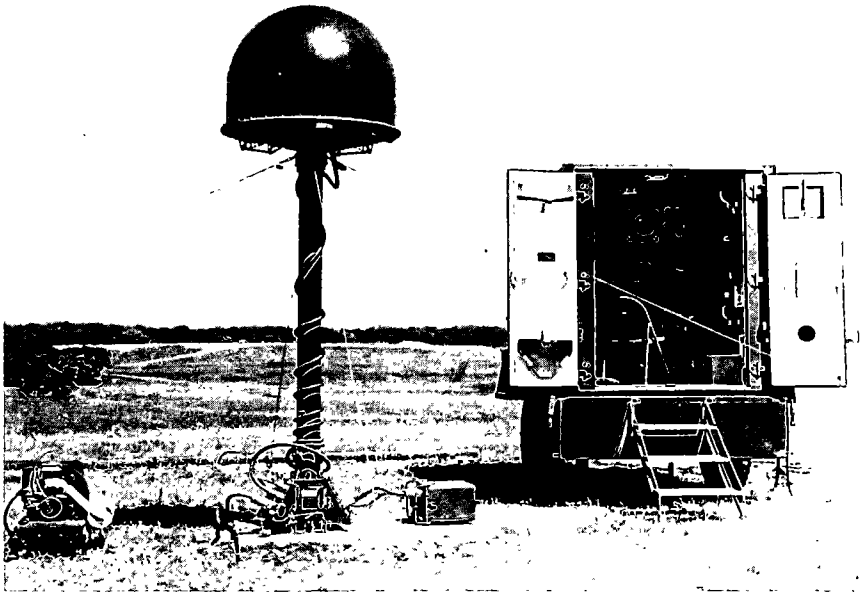

Figure 1. Radar set AN/TPS-25.

b. All components of the radar set are secured within the shelter during travel to prevent damage. Components which are operated outside the shelter are provided with quick release latches for rapid removal.

c. The components of the radar set AN/TPS-25 are discussed in detail in TM 11-5840-217-10 and TM 11-6115-203-12, to include nomenclature, technical characteristics, and operation of the equipment.

d. All equipment listed in *a* above is transported in a 1½-ton cargo trailer and a 2½-ton cargo truck.

CHAPTER 2

ORGANIZATION

4. General

Radar sections, equipped with the radar set AN/TPS-25, are organic to headquarters and headquarters battery, division artillery. The mission of the radar section is moving target detection.

5. Composition of the Radar Section

The radar section consists of seven enlisted men as follows:

- a. Section chief.
- b. Senior radar operator.
- c. Radar mechanic
- d. Two radar operators.
- e. Two radio teletype operators.

6. General Duties of Personnel

a. *Section Chief.* The section chief is the noncommissioned officer in command of the section. He is responsible to the officer in charge for—

- (1) Training and efficiency of the section personnel.
- (2) Selection and occupation of the radar position when so directed.
- (3) Supervision of emplacement, march order, operation, maintenance, and inspection of section equipment.
- (4) Compliance with safety precautions.
- (5) Preparation of field fortifications for protection of equipment and personnel.
- (6) Supervision of the necessary survey for antenna orientation.
- (7) Local security.
- (8) Camouflage discipline.
- (9) Chemical, biological, and radiological warfare training.
- (10) Maintenance of the section area.

b. *Senior Radar Operator.* The senior radar operator is second in command of the section. His principal duties are to—

- (1) Assist the section chief in the performance of his duties.
- (2) Supervise the operation of the section in the absence of the section chief.
- (3) Supervise the operation 1st echelon maintenance of the radar set.
- (4) Assist in performing the necessary survey for antenna orientation.
- (5) Perform other duties assigned to him by the section chief.

c. Radar Mechanic. The radar mechanic is responsible to the chief of section for second echelon maintenance of the radar. He supervises the operators in the replacement of certain parts and is personally responsible for making checks and adjustments beyond the capability of the operators.

d. Radar Operators. The radar operators assist the senior radar operator in the performance of his duties. They operate and perform preventive maintenance on the generator power unit PU-450/G. They are assigned additional duty as light truck drivers and perform preventive maintenance on their assigned vehicles.

e. Radioteletype Operators. The two radioteletype operators maintain the section communication equipment. They operate and perform preventive maintenance on the radio set control group, the radio teletypewriter set AN/GRC-46, and the power generator. They are assigned additional duty as light truck drivers and perform preventive maintenance on their assigned vehicle.

Note. All members of the radar section will act as crewmen to emplace, operate, maintain and march order the radar set AN/TPS-25 and the communication equipment of the section.

CHAPTER 3

TACTICAL EMPLOYMENT AND POSITION REQUIREMENTS

7. General

The tactical employment and position requirements for the radar set AN/TPS-25 are based on the tactical and technical factors which influence the operation of the radar set in accomplishing the moving target detection mission in selected avenues of approach. The suitability of a radar position can only be determined by the accomplishment of the assigned mission from that position.

8. Selection of Site

a. The primary consideration in the selection of the radar position is the technical capabilities and limitations of the radar set.

b. The selection of general position areas is the responsibility of the division artillery commander. He is assisted by the intelligence officer (S2) who takes the necessary measures to assure complete coverage of specific areas during the hours of darkness or periods of limited visibility.

c. The general area in which the radar position may be selected is designated by the division artillery commander based on the recommendations of the intelligence officer (S2). The area should be large enough to allow the platoon commander (chief of section) to select the actual radar position on the basis of technical considerations affecting the operation of the radar. The radar position, if possible, should be located to simplify communications, facilitate survey, and enable the section to take advantage of any defensive perimeter. Depending on the areas to be observed and the terrain, the normal radar position will be located from 1,000 to 2,000 meters behind the forward edge of the battle area.

d. After designation of the general position area, the platoon commander (chief of section) makes a reconnaissance before making the actual selection of the radar position. If time permits, this reconnaissance will be divided into two phases—a map reconnaissance and a ground reconnaissance.

- (1) The map reconnaissance is made to determine, but is not limited to the following:
 - (a) Possible site locations.
 - (b) Routes into and out of the area.
 - (c) Identifying landmarks.
 - (d) Adjacent units.
- (2) A ground reconnaissance follows the map reconnaissance to insure a rapid occupation of the selected position. The ground reconnaissance is based on the tactical and technical considerations for the radar. This reconnaissance enables the platoon commander (chief of section) to make decisions and issue orders concerning the following:
 - (a) Exact location of the radar.
 - (b) Location of the radar operations center.
 - (c) Location of the truck park.
 - (d) Routes into and out of the area.
 - (e) Searching and marking the area for mines.
 - (f) Local security (to include camouflage and defense against air and ground attack).
 - (g) Selection of alternate positions.

Note. The above list is not all-inclusive and should be modified as dictated by the particular mission, situation, and terrain. Since time for reconnaissance generally is limited, the reconnaissance must be organized so that it can be accomplished as completely as possible in the time allotted.

9. Tactical Considerations

a. The tactical considerations in selecting a radar site are similar to those considered in choosing a position for a field artillery firing battery of like unit. Normally, these considerations should include—

- (1) *Communications.* The radar section is authorized wire, radio, and radio teletypewriter equipment to establish the required communication with the parent unit. The selected radar position must permit the establishment of the required communications. For communication diagram see FM 6-10, Field Artillery Communications.
- (2) *Concealment.* In selecting a site for the radar, advantage must be taken of natural concealment, such as trees and shrubs.
- (3) *Cover.* The radar with the exception of the antenna, must be emplaced in defilade to the enemy to afford personnel and equipment all possible protection from hostile fire.

- (4) *Routes of approach.* A site should be selected that has more than one route of approach that will allow occupation without being observed by the enemy. Road conditions, overhead clearances, bridges, streams, and fords must be considered.
- (5) *Security.* If possible, a site should be selected within an established defense perimeter. This will ease the local security requirements for the radar section.
- (6) *Survey.* The closer the site is to a firing battery or a known survey point, the more rapidly survey or organic radar personnel can determine the coordinates and altitude of the radar and the azimuth to a known point for antenna orientation.

b. Since emplacement of the radar set AN/TPS-25 will be accomplished during darkness or periods of poor visibility, tactical planning and preparation must be more detailed. Camouflage and concealment must be more thorough as visibility improves. The antenna, however, cannot be protected from enemy fire since the radar requires line of sight to the target area.

10. Technical Considerations

a. The radar AN/TPS-25 requires line of sight from the antenna to the target area. The antenna may be installed directly on the receiver-transmitter or on one, two, or three mast sections. When the mast sections are required, emplacement time is increased.

b. The equipment shelter must be located within the length of the connecting cables between the receiver-transmitter and the equipment shelter (servo data coordinator). Maximum distance between the two installations is 225 feet. The power unit must be located within 100 feet of the equipment shelter (power supply).

c. The power unit should be positioned so that the sound and smoke from the unit will not disturb the radar operator or aid the enemy in locating the unit.

d. The radar position is selected to detect specific types of targets as required by the mission. For detection of moving vehicles the maximum range is 18,280 meters. For detection of moving personnel, the maximum range is 4,500 meters.

e. Target aspect, which must be considered in selecting the radar position, is a determination of the most likely motion of the target with respect to the radar-target line. The AN/TPS-25 radar detects movement which involves a change in range; therefore, the radar should be positioned so that movement in enemy areas under surveillance will be approximately parallel to the line of surveillance.

CHAPTER 4

EMPLACEMENT AND MARCH ORDER

Section I. GENERAL

11. Transportation of Equipment and Personnel

The equipment and personnel of the radar section are transported in three section vehicles.

a. The first vehicle is a 2½-ton truck which tows the 1½-ton trailer. All components of the radar set AN/TPS-25 are stored in the equipment shelter (fig. 2) which is mounted on the 1½-ton trailer.

b. The second vehicle is a ¾-ton truck which carries the radio teletypewriter set AN/GRC-46.

c. The third vehicle is a ¾-ton truck which carries a radio set AN/VRC-9 and POL for operation of the power units.

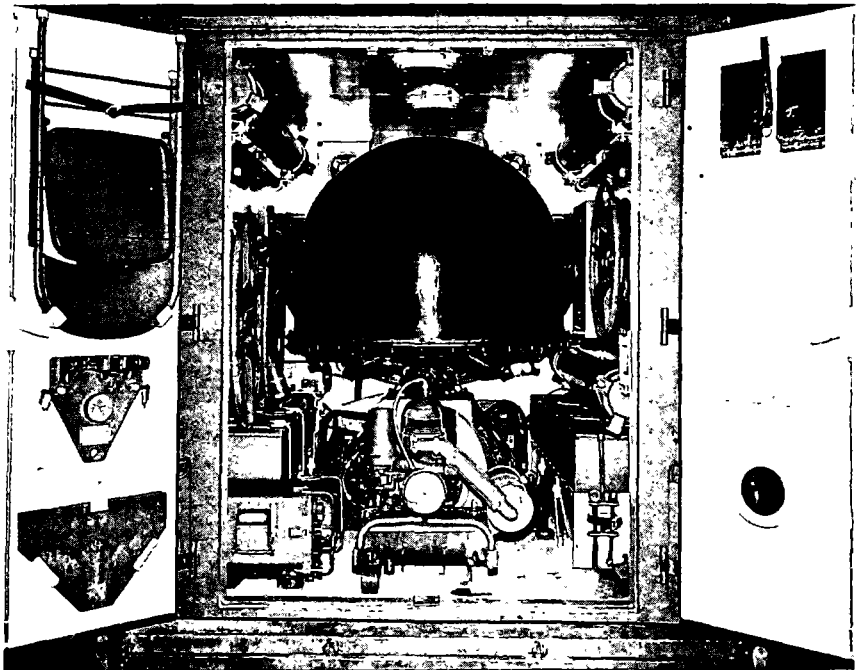

Figure 2. Interior of shelter with components stored.

12. Organization of the Radar Site

a. The radar site consists of the following installations:

- (1) Radar operations center.
- (2) Antenna with receiver-transmitter.
- (3) Power unit.
- (4) Radio teletypewriter set AN/GRC-46.
- (5) Motor park.

b. The radar chief of section is responsible for the reconnaissance, selection, occupation, and organization of the position. Dispersion of (1) and (2) in *a* above is limited to a maximum distance of 225 feet and dispersion of (3) in *a* above in relation to (1) is limited to 100 feet, the only other limitation being mutual accessibility.

Section II. EMBLACEMENT

13. General

a. The emplacement procedures listed in paragraph 14 are based on a team consisting of the following personnel:

- (1) Section chief (SC).
- (2) Senior radar operator (SRO).
- (3) Radar mechanic (RM).
- (4) Two radar operators (numbers 1 and 2).

b. The two radio teletypewriter operators are responsible to the section chief for the location and operation of the radio teletypewriter set AN/GRC-46.

c. Caution must be exercised by all personnel in removing components from the equipment shelter to prevent damage to equipment and injury to personnel.

d. For safety, the stability jack at the rear of the trailer must be lowered before the trailer is uncoupled from the prime mover.

14. Individual Duties

Individual duties of section personnel in emplacing the radar are as follows:

Step 1. Section Chief (SC) Designates location of section installations. Commands PRE-PARE FOR ACTION. Directs and supervises all phases of emplacement.

Step 2. No. 1. Lowers stability jack at rear of trailer.

- | | | |
|-----------|--------------|---|
| | SRO, RM | Uncouple trailer from prime mover and orient trailer as directed by section chief. |
| | No. 2. | Sets trailer hand brake and chocks trailer wheels. |
| Step 3. | SRO | Opens the two shelter doors (fig. 2). Removes center post from shelter doorway. |
| | RM | Loosens and removes clamps holding engine generator. |
| | SRO, RM | Remove generator from shelter and carry it to the operating position. |
| | No. 1, No. 2 | |
| Step 4. | SC | Removes the modulator unit from its mount. |
| | No. 1, No. 2 | Carry modulator unit to antenna position. |
| Step 5. | SRO, RM | Remove antenna receiver transmitter assembly from shelter and carry to antenna position. |
| | No. 1, No. 2 | |
| Step 6. | SRO, RM | Loosen three cable reels from wall of shelter and move reels to rear of the shelter. |
| Step 7. | No. 1, No. 2 | Lower cable reels to ground and position cables as required for the installation. |
| Step 8.* | SRO, RM | Remove mast section and two boom sections from shelter wall, if required. |
| Step 9.* | No. 1, No. 2 | Carry mast and boom sections to antenna location. |
| Step 10.* | SRO, RM | Remove the necessary equipment (fig. 3) from accessory box to emplace antenna (fig. 1) : sledge hammers, three base plate stakes, four guy-wire stakes, four winch hoists and handles, four guy wires, measuring ropes A and B, and two dacron guy ropes. Replace center post in shelter doorway. |
| Step 11.* | No. 1, No. 2 | Carry all equipment listed in step 10 to antenna location. |

*Those steps marked with an asterisk are used if mast sections are used in the antenna installation.

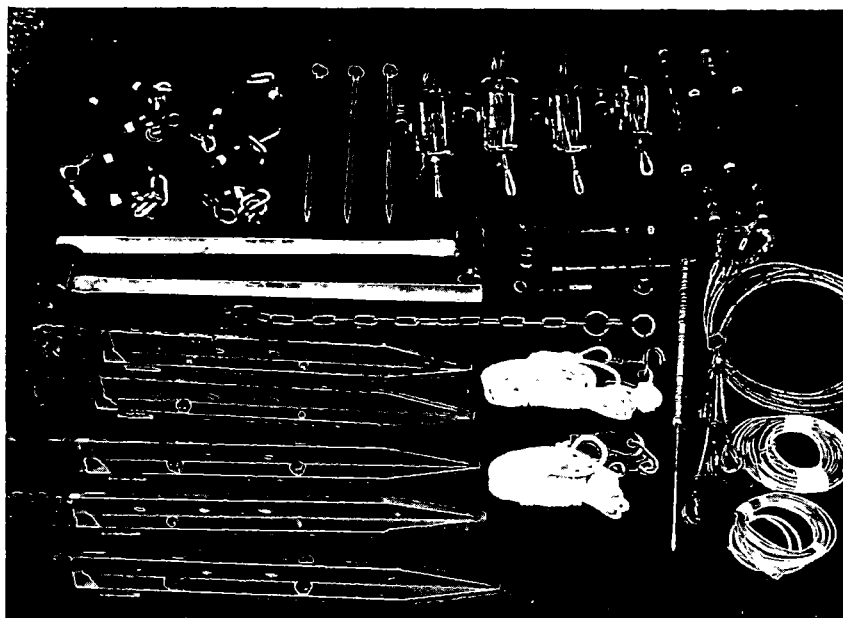

Figure 3. Accessories equipment.

Step 12.* SC, SRO, RM
No. 1, No. 2

a. Orient base plate, used only with mast sections, so socket is over antenna site stake and small end pointed toward area of interest.

b. Drive round headed stake through each side hole of base plate. (*Do not strike base plate with sledge hammer.*)

c. Lay out guy wire stakes and measuring ropes for antenna.

d. Place center link of measuring rope A over the socket of base plate and stretch the shorter section toward the area of interest. Drive guy wire stake into ground at point marked by link at end.

Note. All guy wire stakes should be driven at a 60° angle with the ground and pointing directly away from the

* Those steps marked with an asterisk are used in the antenna installation.

base plate. The part containing the holes should face the base plate and should be driven into the ground until the center hole is just above ground level. If the soil is sandy, the stake plates must be fastened to the stakes so they will not pull out, and two stakes, with chain support attached to each, must be used at the first guy wire stake position.

e. Stretch longer section of measuring rope A away from the area of interest and in a straight line with the shorter section and the front stake. Drive a round-headed stake into the ground and through the ring at end of the measuring rope.

f. With the measuring rope B, pass one end over the round headed stake and stretch to the left of the base plate. Keeping the center link of the A rope over the base plate socket, stretch the 20-foot section to the left of the base plate. Overlap the free ends of the ropes A and B, stretch tightly, and drive a guy wire stake at the point marked by the overlapping ends.

g. Repeat this procedure to the right of the base plate. Pull up the round-headed stake and drive it through the third hole in the base plate. Drive fourth guy wire stake in hole where round-headed stake was removed. Remove measuring ropes and return to accessory box.

h. Disconnect the antenna from the receiver-transmitter.

i. Attach receiver-transmitter to base plate, fully raise four jack pads to avoid damage, and tilt receiver-transmitter so that carrying handles, at the rear, are resting on the ground.

j. Remove cover from one end of a mast section and mate the mast to the socket at top of receiver-transmitter.

k. Mate second mast section to the first after removing protective covers.

l. Move antenna support leg to out position and mate the third mast section to the antenna making sure the antenna rests on the support leg to prevent damage to the radome and insure that antenna stops face away from the area of interest.

m. Mate the mast section of the antenna to the sections attached to receiver-transmitter and connect the antenna cable (W2801) to the jack on the bottom of the antenna and secure to each mast section with cable clamps. (*Do not attach to receiver-transmitter until antenna is erected.*) Open the two breather ports on the bottom of the antenna.

n. Fasten the four guy wires to the eyelets on the antenna mast coupling using the end with the match hook.

Note. The match hook has a tendency to uncouple unless it is under tension. The shackles from the lifting harness may be used to replace the match hooks.

o. Attach a winch hoist to the lower hole of each guy wire stake, pull winch cable out until it can be fastened to the appropriate guy wire link.

Note. When using two or three mast sections, the boom is used.

p. Attach snap hooks at the end of the dacron guy ropes to

the shackle where the front winch cable (toward the area of interest) fastens to the guy wire.

q. Assemble the two sections of the boom and place the pin at the end through the shackle where the guy ropes were fastened.

r. Raise the boom and place the lower end in the socket on the receiver-transmitter.

s. Fasten the dacron guy ropes to the side stakes with the guy rope lock and adjust the ropes so the boom is vertical and the ropes are taut.

t. Remove slack from side and rear winch cables and guy wires. Antenna is prepared for erection (fig. 4).

u. Using the winch at the front stake, slowly and carefully raise the antenna while insuring that the boom remains in line with antenna and front stake.

v. Use guy ropes and guy wire to keep antenna and boom in proper position.

w. When antenna reaches a vertical position, take up slack in guy wires, remove guy ropes, and connect antenna cable to the receiver-transmitter.

Step 13. SRO, RM

Position modulator and connect cables W2802 and W2803 from modulator to receiver-transmitter. Connect power cable W2813 and pigtail cable W2814 from shelter to power unit. Position grounding post at shelter junction box and connect grounding wire to shelter cable port.

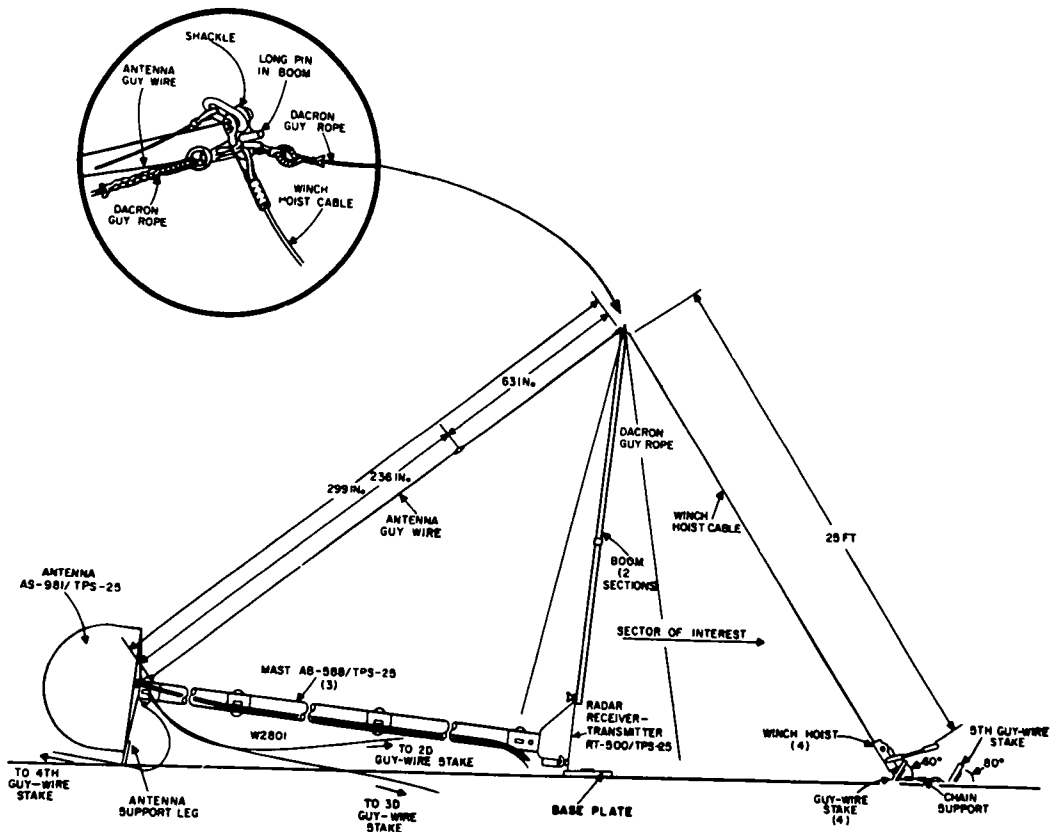

Figure 4. Layout of antenna for erection.

	No. 1, No. 2	Connect cables W2804, W2805, and W2806, as required, from receiver-transmitter to shelter. Inside the shelter, connect cable W2601 from power distribution box to the coordinator. Check cable connections for tightness.
Step 14.	RM	Starts generator engine.
	SRO	Applies power to radar and performs preoperation checks.
	SC	Levels the antenna. If mast sections are used, the four leveling lamps on the receiver-transmitter mast coupling are used. If any of the lamps are lighted, the antenna is not level and guy wires must be tightened or loosened until all lamps are out. If mast sections are not used, levels the antenna by adjusting the four jack screws mounted on the corners of the receiver-transmitter.
	SRO, No. 1	Place radar set control unit and plotting board in the operating position.

Section III. MARCH ORDER

15. General

Precautions must be taken to prevent injury to personnel and damage to equipment during march order.

16. Individual Duties

The section chief directs the operations, giving such orders, instructions, and signals as may be required to expedite and coordinate the work of the section. Individual duties of personnel in march order of the radar are as follows:

- | | | |
|---------|---------------|---|
| Step 1. | Section chief | Commands MARCH ORDER. Directs and supervises all phases of march order. |
| Step 2. | SRO | Turns off power switch of power supply. |

	RM	Stops engine generator and disconnects pigtail cable W2814 from the generator.
Step 3.	SRO, RM, No. 1, No. 2	Disconnect all cables from the receiver-transmitter. Lower antenna by reversing procedures in step 12 of emplacement if mast sections have been used. Remove mast sections, assemble antenna receiver-transmitter assembly and carry the assembly to rear of shelter.
	SRO, No. 1	Inside shelter, disconnect cable W2601 from power distribution and the coordinator. Return and secure plotting board and radar set control in traveling position.
	RM, No. 2	Carry modulator unit, mast sections, and guying equipment to rear of shelter. Stow and secure mast sections and guying equipment.
	No. 1, No. 2	Replace cables on reels and return to rear of shelter.
	SRO, RM	Secure cable reels in shelter.
	SRO, RM No. 1, No. 2	Lift antenna receiver-transmitter assembly to shelter floor, slide it into position, and secure it in the traveling position. Carry generator to shelter, replace and secure in traveling position. Secure modulator unit in shelter.
	SC	Inspects and secures shelter for travel. Hooks trailer to prime mover. Raises stability jack at rear of trailer, removes chock blocks and releases hand brake.

CHAPTER 5

PREOPERATION AND PERFORMANCE CHECKS

17. General

The procedures outlined in this chapter are necessary for efficient operation of the radar set AN/TPS-25. They should be accomplished in sequence when possible.

18. Preliminary Adjustment

Before power is applied to the radar set AN/TPS-25, the following preliminary adjustments should be made:

a. General. Open all vents (three on coordinator; two each on the modulator, receiver-transmitter, power supply, and radar set control). If shelter or heater fans are to be used, open the four shelter vents.

b. Power Unit. Attach pigtail cable W2814 to terminals T1 and T3 on the junction box. Set the power unit controls as follows:

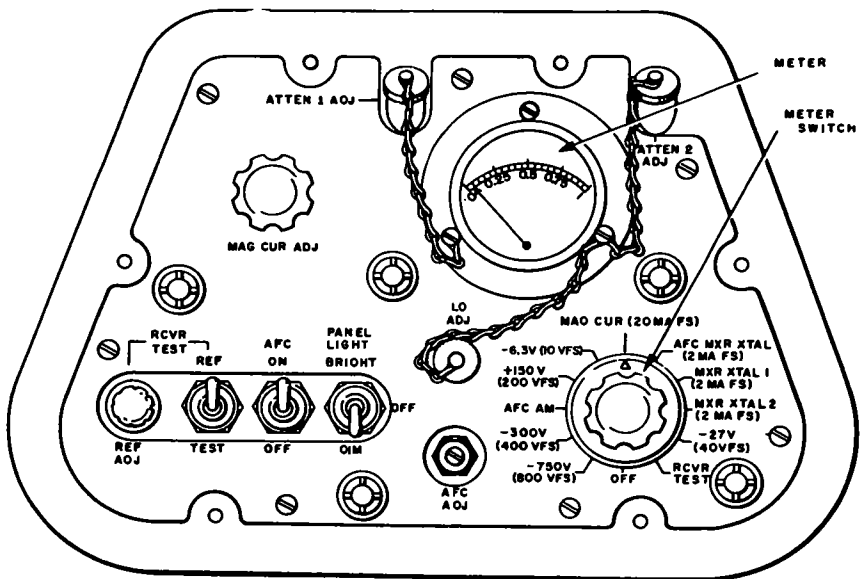

Figure 5. Receiver-transmitter meter panel.

- (1) PHASES switch in position 1. Safety pin must be in place to prevent switch being placed in 3.
- (2) VOLTS switch in center (OFF) position. Safety pin must be in place to prevent switch being placed in H1.
- (3) Voltage regulator knob marker in midposition.

c. *Receiver-Transmitter.* Set the receiver-transmitter controls (fig. 5) as follows:

- (1) PANEL LIGHT switch OFF and leveling light covers closed, if under blackout conditions.
- (2) Place the meter selector switch in the OFF position.
- (3) Turn the MAG CUR ADJ control fully counterclockwise.

d. *Shelter Junction Box and Power Supply.* Turn all switches and circuit breakers OFF.

e. *Radar Set Control.* Set the radar set control switches and controls as follows:

<i>Control</i>	<i>Position</i>
AUTO-MAN	3 (MAN SEARCH)
INTENSITY	Midpoint
FOCUS	Midpoint
SCOPE GAIN	Midpoint
VERTICAL	Midpoint
VOLUME	Midpoint
SPEAKER VOLUME	Midpoint
(When speaker is used)	
PANEL LIGHT	Fully clockwise
RCVR GAIN (Right side)	Fully clockwise
MAP SCALE	Scale of map on plotting board 1:25K when plotting board is not used.
MAP ZERO	Down
SECTOR WIDTH	360

19. Starting Procedure

a. Start the engine generator PU-450/G and, after warmup, adjust the voltage output to 115 volts. Set VOLTS switch to LO.

b. In the shelter, turn the main circuit breaker ON. If fans, light, or heater are to be used, turn the SHELTER circuit breaker and the required switches ON. Turn the RADAR circuit breaker ON.

c. Turn the power supply unit power switch ON. Regulate the power supply unit voltage until the needle of the voltmeter on the coordinator is on the red line.

20. Operational Checks

a. On the receiver-transmitter panel (fig. 5), check each read-

ing on the METER switch against the correct meter readings as follows:

<i>Position</i>	<i>Correct value</i>	<i>Correct meter reading</i>
— 750V (800 VFS)	750	.79 to 1.0
— 300V (400 VFS)	300	.63 to .86
AFC AM		.35 to .85 (fluctuating)
+150V (200 VFS)	150	.62 to .86
— 6.3V (10 VFS)	6.3	.53 to .73
MAG CUR (20 MA FS)		0
AFC MXR XTAL (2 MA FS)		0 to .75 (fluctuating)
MXR XTAL 1 (2 MA FS)		0 to .75 (fluctuating)
MXR XTAL 2 (2 MA FS)		0 to .75 (fluctuating)
— 27V (40 VFS)	27	.57 to .78
RCVR TEST		Not used by operator.

Return the selector switch to the MAG CUR position.

b. At the radar set control panel—

- (1) Rotate the elevation handwheel to the upper and lower limits (+265 mils to —265 mils). The elevation WARNING lamps should light at maximum and minimum elevations.
- (2) With the plotting board arm at the center of the plotting board, declutch the plotting board arm and rotate the azimuth handwheel to right and left limits. (The limits should be 6,750 mils apart.) The azimuth WARNING lamp should light at each limit.
- (3) Position the azimuth handwheel so that the azimuth reading is approximately half way between the limits. Engage the plotting board arm. Rotate the azimuth handwheel first in one direction, then in the other. The plotting board arm should follow these movements. Rotate the range handwheel to increase, then decrease, range. The range dial and the “bug light” on the plotting board arm should follow these movements.

c. Level the antenna.

d. At the radar set control panel, turn the RADIATE switch ON. (The transmitter will not come on until 3 minutes after power is applied.) The RADIATE indicator lamp should light, and a baseline should appear on the A scope (fig. 6).

e. On the receiver-transmitter, recheck the following positions of the meter, then return the selector switch to the MAG CUR position.

<i>Position</i>	<i>Correct value</i>	<i>Correct meter reading</i>
MAG CUR (20 MA FS)	14	.7 (Adjust if necessary)
AFC MXR XTAL (2 MA FS)	.7	.34 to .41
MXR XTAL 1 (2 MA FS)	.7	.34 to .41
MXR XTAL 2 (2 MA FS)	.7	.34 to .41

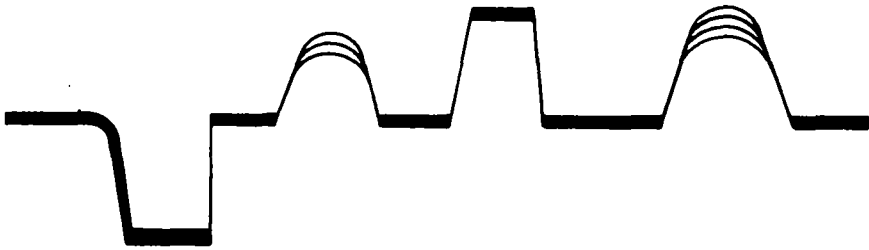

Figure 6. A-scope presentation.

- f. On the radar set control panel:
- (1) With VOLUME control (and SPEAKER VOLUME control if speaker is used) set at midpoint, adjust RCVR GAIN until background noise is clearly audible.

Note. NO target should be in the range gate when this adjustment is made.
 - (2) Set VOLUME, SPEAKER VOLUME, INTENSITY, FOCUS, VERTICAL, and SCOPE GAIN controls to suit the individual operator.
 - (3) Check each position of the AUTO-MAN switch for correct functioning.
 - (a) AUTO SEARCH—sector scan, automatic range search, A-scope presentation.
 - (b) AUTO RANGE—automatic range search, manual control of azimuth, A-scope presentation.
 - (c) MAN SEARCH—manual control of azimuth and range, A-scope presentation.

Note. When the AUTO-MAN switch is changed from position 3 to 4 (or 4 to 3), the antenna should switch feedhorns. This will be indicated by a momentary disappearance of sound and scope presentation.
 - (d) MAN TRACK AUDIO—manual control of azimuth and range, audio presentation (fig. 7) on scope (horizontal bars).
 - (e) MAN TRACK VIDEO—manual control of azimuth and range, A-scope presentation.
- g. The set is now ready to be oriented and operated.

21. Normal Stopping Procedure

- a. Turn RADIATE switch OFF.
- b. Set AUTO-MAN switch at position 3 (MAN SEARCH).
- c. Turn power switch on power supply OFF.
- d. Return all other controls to positions at which they were set prior to starting.

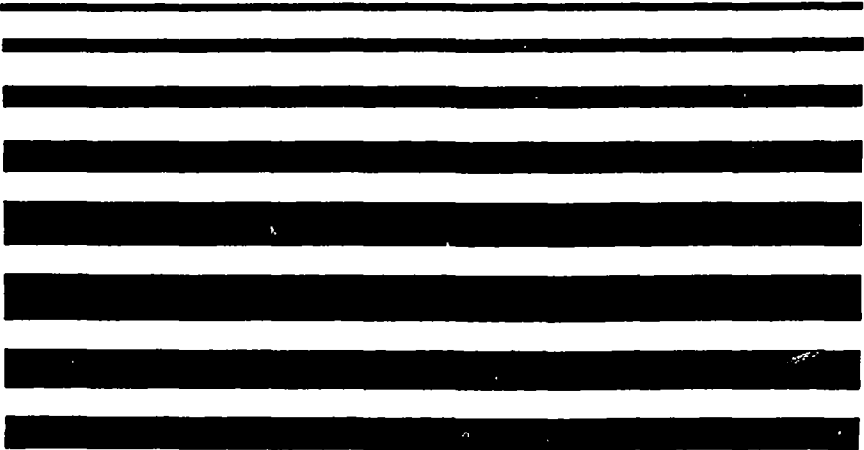

Figure 7. Audio presentation.

22. Emergency Stopping Procedure

a. In the shelter, turn off either the MAIN circuit breaker on the shelter power distribution box or the POWER switch on the power supply.

b. At the engine generator, place the VOLTS switch in its center or OFF position. Stop the engine-generator by holding down the STOP button.

23. Antenna Orientation

a. General. Before the antenna can be oriented, (fig. 8), the ground location must have been determined by some method of survey and the grid azimuth from the antenna to an orienting stake must be known. The orienting stake should be placed in the general direction of the area of interest, and beyond the minimum range, at least 500 meters, from the set. The antenna must be erected facing the area of interest, leveled, and the preoperational checks accomplished.

b. Procedure for Antenna Orientation. To orient the antenna it must be pointed in a direction of known azimuth and the azimuth counter made to read this azimuth. Since the antenna cannot be pointed optically, a moving target is required to orient the antenna; this moving target is placed over the orienting stake. It can be one of many things, such as a helmet or canteen swung back and forth, a man running in place, a rotating reflector, or other similar device. Once this moving target is established over the orienting stake, the actual orientation may be accomplished

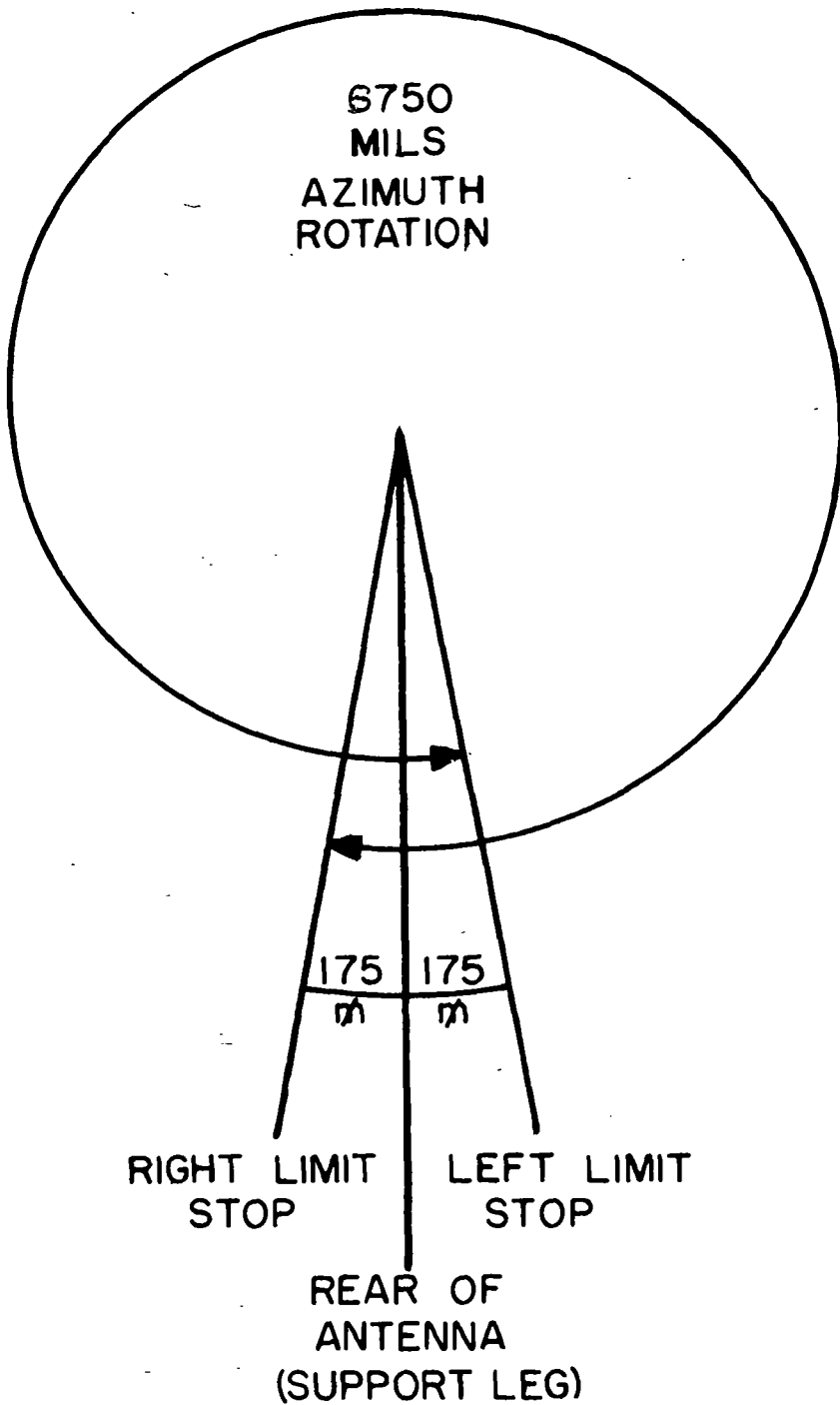

Figure 8. Azimuth coverage of antenna.

as follows: The plotting board arm is declutched by turning the locknut (small knob) located in the center of the plotting board control knob to the left (ccw). Center the plotting board arm by means of the control knob. With the RANGE handwheel set the RANGE counter to the minimum range of the set (450 meters). Rotate the antenna until the AZIMUTH WARNING light comes on, noting the direction of rotation. Loosen the locknut on the SECTOR CENTER knob and rotate the line on the flange in the same direction as the antenna until it is approximately 175 mils beyond the reference line on the panel; then lock the knob with the locknut. The line on the flange will now indicate the direction of the antenna with respect to the limit stop (or the antenna support leg). The operator may use this to aid him in the initial location of the orienting target. The AUTO-MAN switch is then placed in the AUTO RANGE position (position 2) causing the radar set to strobe outward 900 meters from minimum range. The operator searches manually in azimuth for the return from the orienting target. When the return from the target is identified, the operator places the AUTO-MAN switch in the MAN SEARCH position (position 3) and peaks the aural return from the target. When this is done the AUTO-MAN switch is moved to the MAN TRACK AUDIO position (position 4), and the target return is again peaked utilizing the narrow beam. Upon peaking the return in position 4 the operator declutches the AZIMUTH ORIENTATION control by tightening the locknut (large knob) by turning it clockwise and loosening the control (small) knob by turning it sharply counterclockwise. The AZIMUTH counter is then set to the azimuth of the orienting stake by turning the AZIMUTH handwheel. When the AZIMUTH counter is correctly set, it is locked by the AZIMUTH ORIENTATION control knob. Tighten the control (small) knob clockwise while holding the AZIMUTH handwheel; then turn the locknut (large knob) counterclockwise. The azimuth orientation should be checked by turning the antenna off the orienting target, then repeaking the target return and checking the azimuth indicated on the azimuth counter which should read the surveyed azimuth to the orienting stake.

24. Map and Plotting Board Orientation

a. General. The orientation of the map and plotting board (fig. 9) must be performed after the antenna is oriented. The ground location of the antenna must be known. This location, as well as the location of the area of interest is marked on the map. An azimuth reference line is drawn on the map from the antenna

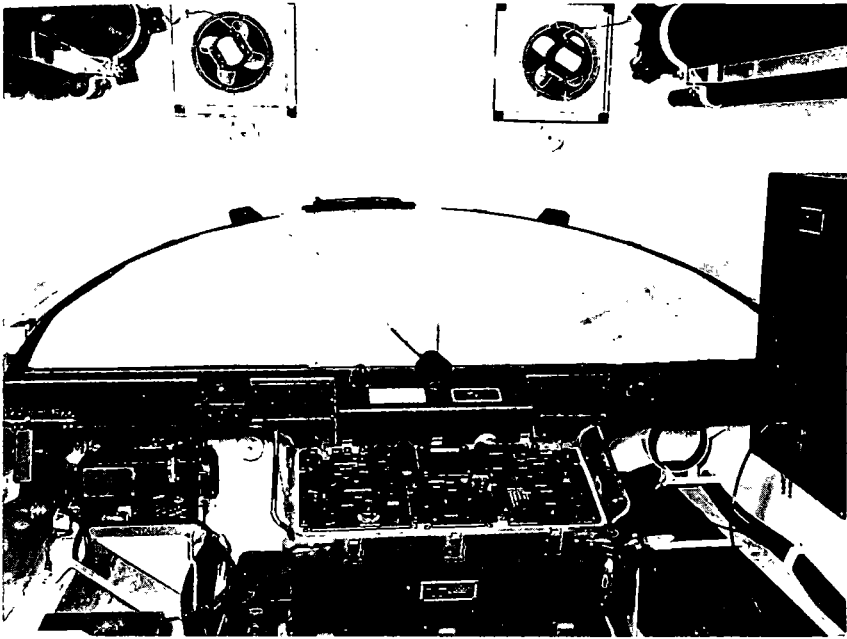

Figure 9. Radar set control and plotting board with map mounted.

location parallel to the grid line which passes closest to the area of interest. The azimuth of this line is determined and noted (0, 1,600, 3,200, or 4,800 mils). The plotting board arm which was unlocked by loosening the plotting board control knob locknut in antenna orientation should still be unlocked.

b. Procedure for Orientation of the Map and Plotting Board. To orient the map and the plotting board, place the map on the plexiglas cover of the plotting board so that the light on the plotting board arm will indicate the place on the ground that the radar is observing. To accomplish this, the orientation of the antenna, plotting board arm, and map must all be correlated. Since the light on the plotting board arm is used as the indication on the map, it is also used to locate and orient the map on the plotting table. To do this, the RANGE handwheel is turned fully counterclockwise to minimum range. Then place the MAP ZERO switch, located on the right side of the radar set control, in the zero position. Manually rotate the range coupling between the radar set control and the plotting board until the RANGE counter in-

dicates zero meters. This process should place the light on the plotting board arm at the origin of the plotting board, which represents the location of the radar set antenna. To check that it is at the origin, rotate the arm and make sure that the light does not move. The map is now placed on the plexiglas cover so that the antenna position is exactly over the indicator light on the plotting board arm. Rotate the map so that the area of interest is roughly in the center of the plotting board. Exact placement of the area is not important, but the placement of the antenna location is quite important. Fasten the map in position on the plexiglas and either tear off or roll up the portion of the map which overhangs the edge of the plotting board. Place the MAP ZERO switch in the operating position (toward the bottom of the radar set control) and crank the RANGE handwheel until the plotting arm light is near the far edge of the map. With the AZIMUTH handwheel, set the AZIMUTH counter to the azimuth of the reference line drawn from the antenna position parallel to a grid line (0, 1,600, 3,200, or 4,800 mils). Position the plotting board light directly under this reference line on the map with the plotting board azimuth control knob; then tighten the locknut by turning it clockwise. Check the setting by running the range in and out and observing that the light moves along the reference line. Set the MAP SCALE switch on the radar set control to the appropriate scale for the map being used (1:25K or 1:50K). If the plotting board is not being used, set the MAP SCALE switch to the 1:25K position. The SECTOR CENTER control may now be set to indicate the sector of interest.

c. Procedure for Orientation Using Overlay. It is possible to use an overlay directly on the plotting board instead of a map. The overlay must show the radar position, an azimuth reference line, and the area (areas) of interest. It is desirable that the area of interest be broken into several sections, each small enough to be scanned by the radar in one setting for search. Or, better still, specific points to be observed may be indicated on the overlay. Targets observed at any of the points may be reported as targets at a certain check point or concentration number or however the points are identified on the overlay. The overlay is placed on the plotting board in the same manner as the map. The radar position is placed over the origin of the board with the points of interest to the top of the board. The plotting board arm is then oriented using the azimuth reference line drawn on the overlay. If each of the points is identified on the overlay, it is not necessary to utilize the coordinate counters to report the target location.

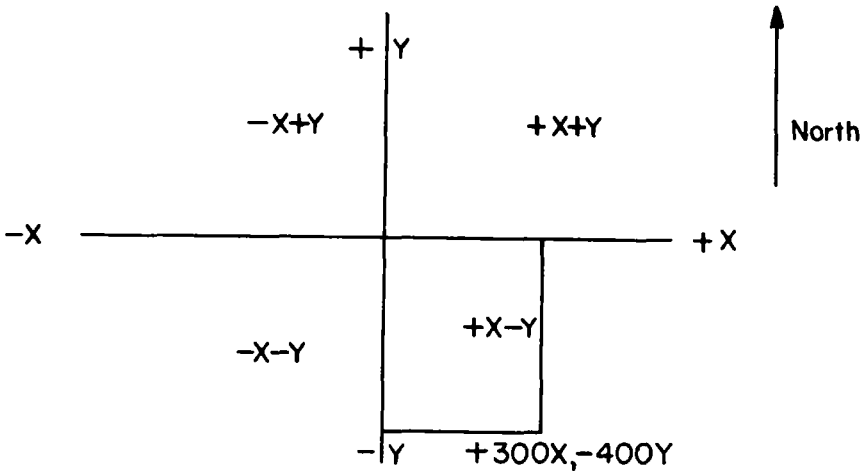

Figure 10. Cartesian coordinates.

25. Orientation of X and Y Counters

a. Procedure.

- (1) After the map and plotting board have been oriented with the antenna and the AZIMUTH COUNTER, the X and Y counters may be set to indicate the coordinates of the targets located. These counters may be set in one of three ways; to indicate grid reference of the target, to indicate Cartesian coordinates (fig. 10) from either the radar set or from an adjacent position such as a firing battery.
- (2) Cartesian coordinates are used in mathematical problems to indicate the location of a point with respect to an origin. The distance is indicated by a numerical value, and the direction by the combination of plus or minus sign with X and Y values. North is indicated by $+Y$; south by $-Y$; east by $+X$; and west by $-X$. Therefore, northeast would be indicated by $+X+Y$, southwest by $-X-Y$. Assigning a numerical value to X and Y would identify a point located with reference to the origin (radar antenna). For example, $+300X - 400Y$ designates a point 300 meters east and 400 meters south of the radar set.

b. Cartesian Coordinates From the Radar Set. To set the X and Y counters so that the Cartesian coordinates may be read from the radar, first set the ELEVATION counter to zero mils. Set the

RANGE counter to 18,000 meters. Disengage the X and Y counter controls by loosening the locknuts in the center of the respective control knobs. With the AZIMUTH handwheel, set the AZIMUTH counter to either 0 or 3,200 mils, whichever is closer to the area of interest. Set the X counter to zero with the control knob and tighten the locknut. Set the AZIMUTH counter to either 1,600 or 4,800 mils, whichever is closer to the area of interest; set the Y counter to zero; and then tighten the locknut.

c. Cartesian Coordinates From an Adjacent Position. Adjust the counters to indicate the Cartesian coordinates of a target in relation to an adjacent position such as a firing battery. This method of setting the counters is seldom used, but is considered as an additional capability of the plotting system. Set the counters to indicate the Cartesian coordinates of a target with respect to a registration point, thus allowing a shift from the registration point to the target to be read directly from the counters. There are two ways of setting the counters. For the normal method the counters are set as for Cartesian coordinates from the radar set, except that the Cartesian coordinates of the radar set FROM the adjacent position are set into the counters instead of zeroing them. A more rapid but less accurate method is to place the plotting arm light under the adjacent position, and then set the X and Y counters to zero.

d. Grid Reference.

- (1) Setting the X and Y counters to indicate the grid reference of the targets directly is the method most commonly used. This method eliminates the plotting that is required when polar or Cartesian coordinates are used. It permits a faster solution to the problem of target location and permits rapid employment of counter-measures against the target.
- (2) The procedure for setting the counters to indicate grid reference is similar to that for setting for zero. The grid reference of the antenna must be known to the nearest meter. The RANGE counter is set to 18,000 meters, and the AZIMUTH counter is set to either 0 or 3,200 mils, whichever is closer to the area of interest. The ELEVATION counter is set to zero. To avoid running the X or Y counters against their stops or indicating a negative value, the first number of the reference is changed to 5 and the difference is carried as a correction factor. (Example: Easting grid reference is 37628; set 57628 on the +X counter; the correction is — 2.) Set the easting grid reference on the +X counter, with the 5 as the first digit, and mark the correction on the counter with

a grease pencil. The AZIMUTH counter is then set to either 1,600 or 4,800 mils, whichever is closer to the area of interest. Place the northing grid reference on the +Y counter, again making the first digit 5, and mark the correction on the counter.

- (3) When the target is located, the X and Y counters will indicate the grid reference except for the first digit of the easting and northing. The correction, as determined when setting the counters, must be applied to the readings.

26. Calibration of the X and Y Counters

a. Procedures for Calibration. To check the calibration of the counters set the elevation counter to zero and the range to 18,000 meters. Set the azimuth to either 0 or 3,200 mils, whichever shows on the map on the plotting board. The Y counter should read 18,000 meters (plus or minus 140 meters) *more* than the radar coordinates if the azimuth was 0 mils, and *less* if the azimuth was 3,200 mils. The X counter should indicate the radar coordinates (plus or minus 140 meters). Turn the azimuth to either 1,600 or 4,800 mils, whichever shows on the plotting board. The X counter should indicate 18,000 meters (plus or minus 140 meters) *more* than the radar coordinates if the azimuth was 1,600 mils, and *less* if the azimuth was 4,800 mils. The Y counter should indicate the radar coordinates (plus or minus 140 meters).

b. Checking Calibration. After the X and Y counters are calibrated, a problem is set into the radar to check the plotting components. Set the azimuth to either 800 or 4,000 mils. Check the elevation counter for a reading of zero mils and set the range to 14,140 meters. The reading on both the X and Y counters should be 10,000 meters (plus or minus 75 meters) *more* than the radar coordinates if the azimuth was 800 mils, and *less* than the radar coordinates if the azimuth was 4,000 mils. The elevation counter is then set to +143 mils and the range counter is checked for a reading of 14,000 meters (plus or minus 75 meters).

CHAPTER 6

BATTLEFIELD SURVEILLANCE AND MOVING GROUND TARGET DETECTION

Section I. PERSONNEL

27. General

A well trained radar crew is essential to insure timely detection of moving targets. Continuous operation during darkness or periods of limited visibility is required in combat. It is imperative that each man in the section be capable of performing the duties required for operation.

28. Utilization of Personnel

a. The radar normally will not be operated on a 24-hour basis. The enlisted personnel assigned to the radar section must be organized into teams for efficient continuous operation as required. The chief of section and the mechanic are on call continuously and therefore should not be placed on any particular team.

b. Normally two-man teams operate the radar. One man operates the radar set control; the other assists in the operation of the radar set control, operates the communication equipment, and keeps the necessary records. These two men should change jobs approximately every 30 minutes in order to give each man a change of duty. When teams are changed, the personnel on duty should be relieved one at a time, to allow the new personnel to become familiar with the situation.

Section II. BATTLEFIELD SURVEILLANCE AND MOVING GROUND TARGET DETECTION

29. General

The technique employed in detecting moving ground targets with the AN/TPS-25 may be divided into two phases, the automatic search phase and the detection phase.

30. Preliminary Procedures

A sector or sectors of interest will normally be assigned to the radar. When the radar is ready to operate, the azimuth, elevation, and range to the sector of interest are determined. The azimuth is set off on the azimuth counter. The SECTOR CENTER knob is unlocked (by turning the small knob counterclockwise), rotated until the line on the flange of the large knob is lined up with the line on the panel of the control unit, and locked (by turning the small knob clockwise). The SECTOR WIDTH selector switch is set for the desired sector width. The range counter is set to the minimum range of the sector of search. The elevation is set off on the elevation counter.

31. Battlefield Surveillance

Of the five modes of operation used with this set, three are utilized during the search or surveillance phase. Normally, mode 1 will be used for surveillance of the area of interest, with modes 2 and 3 used in turn to determine the approximate azimuth and range to the target.

a. AUTO SEARCH. When the AUTO-MAN switch is placed in position 1 (AUTO SEARCH), the antenna will go into sector scan, using the 180-mil beam. The azimuth dials move to show the azimuth at which the antenna is actually pointed, and the sector scan indicator lamps will show the direction of rotation of the antenna. The range gate will automatically search a 900-meter range sector, starting at the range shown on the range counter and strobing outward. The indicator cathode ray tube presents an A-scope display of ranges from 100 meters less than counter reading to 1,000 meters more than counter reading. Audio return from moving targets in the range gate can be heard in the earphones and/or loudspeaker.

b. AUTO RANGE. When a moving target is detected, the AUTO-MAN switch is changed to position 2 (AUTO RANGE). The antenna will stop scanning (does *not* return to center of sector), and the indicator lamp which was on when the set was taken out of sector scan stays on, indicating the direction of last rotation. Range search continues as before. If the target is no longer heard at any point during range search, the operator turns the azimuth handwheel slowly in the direction *opposite* that indicated by the sector scan indicator lamps (the antenna had apparently gone past the target before the operator took it out of sector scan). Remembering that the range search covers 900 meters, the operator watches the A-scope, noting the location of

the range gate when the moving target is heard in the earphones, and estimates how much the range counter setting must be changed to indicate the range to the target.

c. MAN SEARCH. When the azimuth and approximate range to the target have been determined, the AUTO-MAN switch is moved to position 3 (MAN SEARCH). The range, elevation, and azimuth handwheels are adjusted for maximum (loudest) moving target return. This produces an approximate target location. However, up to this time, the antenna beam width has been 180 mils and any locations made are considerably less accurate than the set is capable of producing.

32. Moving Ground Target Location

After an approximate location has been determined in mode 3, either mode 4 or mode 5, or both, may be used to obtain a more accurate target location.

a. MAN TRACK AUDIO. When a moving target has been located in the wide beam, the operator switches the AUTO-MAN switch to position 4 (MAN TRACK AUDIO). This changes the antenna beam width to 36 mils, and causes the cathode ray tube to display an audio signal rather than its normal A-scope presentation. Azimuth, range, and elevation are all reset to obtain a maximum moving target indication. Target strength is indicated by the distance between the outer horizontal bars appearing on the scope. Target location (either grid or polar coordinates) is recorded and reported.

b. MAN TRACK VIDEO. When a target is moving rapidly, it may be difficult to track in the MAN TRACK AUDIO mode of operation, since no indication is given as to whether movement is in range or in azimuth. In such cases, the operator should change the AUTO-MAN switch to position 5 (MAN TRACK VIDEO). The beam width remains at 36 mils, but the cathode ray tube presentation is again a normal A-scope display and moving targets can be distinguished from stationary targets by their appearance on the A-scope. The size of a moving target fluctuates rapidly, giving it a "spider web" effect, while the size of a stationary target echo remains relatively constant. Any change in moving target range will be visible on the A-scope. Any change in target location which does not show as a range change must, then be a change in azimuth, and the operator can reposition the azimuth handwheel to stay on the target. Use of the MAN TRACK VIDEO mode reduces operator guesswork as to direction of movement and facilitates the tracking of fast-moving targets.

CHAPTER 7

PROCEDURE FOR MINIMIZING THE EFFECT OF JAMMING

33. Electronic Countermeasures

Electronic countermeasures as applied to radar include measures, tactics, and techniques used by the enemy to reduce or nullify the effectiveness of our radar equipment. Such activities can be subdivided into two principal categories, *passive countermeasures* and *active countermeasures*.

a. Passive Countermeasures. Passive countermeasures consist of the means and methods used by the enemy to determine the technical and operational characteristics of opposing radars. By means of monitoring equipment the enemy can intercept and analyze radar signals to determine transmission frequency, pulse repetition frequency, power output, and other such technical characteristics of a radar set. From this information, the enemy can make a reasonable determination of the types and probable uses of opposing radars. The information gained from passive countermeasure activity also is used by the enemy in planning his active countermeasure operations. Passive countermeasures, however, do not affect a radar set directly and, consequently, are not a principal concern of the radar operator.

b. Active Countermeasures. Active countermeasures are the immediate concern of the radar operator since their application affects the operational effectiveness of the radar set directly. These countermeasures are divided into two classes, *jamming* and *deception*. The two classes are further divided into two types, *transmission* and *reflection*.

- (1) *Transmission jamming.* Transmission jamming is produced by an active transmitter operating at or near the radar frequency. The jamming signal may be a straight, continuous wave (cw) signal, frequency modulated (FM) and/or amplitude modulated (AM) by a variety of different waveforms. The jamming also may be produced in "barrage" form (a number of jammers tuned to adjacent frequencies jam a large segment of the frequency band) or in "swept frequency" form (the frequency of the jamming transmission is swept or varied

over a portion of the radar frequency band). The purpose of all jamming is to JAM into the radar receiver signals of sufficient strength to obliterate the return echoes from targets in the area of surveillance. To be successful, the jammer must produce signals that will be accepted by the radar receiver and produce these signals in a strength that will be greater than the target return signals. The relative power of the jammer and the radar transmitters and the distance between these two transmitters are important factors in countermeasure operations.

- (2) *Reflection jamming.* Reflection jamming is produced by large numbers of reflecting items that efficiently return echoes of the transmitted radar signal to the radar set. Like transmission jamming, reflection jamming is intended to flood the radar receiver with strong signals that will overshadow real target echoes.
- (3) *Transmission deception.* Deception differs from jamming in that the deception signals are intended to confuse the radar operator by presenting false targets instead of overshadowing the real target echoes. Transmission deception signals, for the most part, are produced by transmitting devices known as repeaters. These repeaters are triggered by the radar transmitter signal and respond with one or more pulses of energy at the radar frequency. The repeater pulses appear to the radar set as return echoes of its own transmitted pulse. This type of countermeasure is often referred to as "spoofing."
- (4) *Reflection deception.* Reflection deception signals, like those of transmission deception, are intended also to appear as real target echoes. These signals are produced, in most instances, by small rotating or mobilized corner reflectors that reflect back to the source any radar signals they intercept.

34. Counter-Countermeasures

Tactics, techniques, and procedures designed and carried out to reduce the effectiveness of enemy countermeasures are called counter-countermeasures. Usually, counter-countermeasures applications, whether used against jamming or deception, are called antijamming or AJ procedures or operations. The responsibility for AJ operation lies almost entirely with the radar operator. It is of the greatest tactical importance that the radar operator be

able to detect and minimize the effectiveness of enemy countermeasures. Whether or not enemy countermeasures are effective will depend, to a great extent, upon the positive AJ action taken at all echelons by commanders and staff officers, signal and communications officers, technical supervisors, and radar operators. AJ measures must be included in all planning and AJ activities must be controlled and coordinated. The radar operator must be thoroughly and continuously trained to expect countermeasures, to recognize the difference between countermeasure effects and equipment malfunction or other interference, to be able to identify various types of countermeasures, to make adequate countermeasure reports, and to continue operation while under countermeasure attack.

35. Countermeasure Identification

Noise or unusual disturbances do not always indicate countermeasure activity. It may be natural interference resulting from atmospheric disturbances, unintentional interference by friendly equipment, or malfunction of the equipment.

a. Need for Identification. After an interfering signal is recognized as a countermeasure signal, immediate and accurate identification of signal characteristics is essential. It is important that identification be made before AJ action is taken for the following reasons:

- (1) AJ techniques are based on both the types of countermeasures received and the characteristics of countermeasures signal. Application of the recommended AJ procedure against a specific type of countermeasure signal is most likely to enable the radar operator to operate through the countermeasure signals.
- (2) Systematic identification of the countermeasure signal characteristics, followed by prescribed use of AJ devices and equipment controls saves time. The radar operator must avoid haphazard knob-twisting.
- (3) Accurate identification, including location information will be useful to higher headquarters in determining countermeasures signal sources and enemy countermeasures potential.

b. Natural and Unintentional Interference. Unintentional interference is sometimes caused by friendly radio sets, radar sets, or other electronic equipment. Natural interference can result from electrical disturbances in the atmosphere. As a general rule, natural and unintentional interference will not be as persistent as intentional interference and will not have the regularity of

pattern or the directional characteristics usually evident in intentional interference or countermeasures signals. Harmonic interference occurs when a signal from an external source, a multiple or submultiple of the radar operating frequency is also accepted by the radar receiver. When the harmonic interference contains readable intelligence, the origin of the signal can usually be determined.

c. Deception. Because deception signals appear to be real target echoes, skillfully generated transmission deception usually is very difficult to recognize and identify.

- (1) *Transmission jamming.* If the jamming signal is produced at the radar set frequency, to affect only that frequency, the result is called spot jamming. This type of jamming, which permits the jammer to concentrate all its power at one frequency or in a very narrow frequency band, is difficult to work through. The jamming may produce a crackling and rushing noise in the earphones and will cause the radar scope to "blossom" brightly with noise indications. These jamming indications will be much the same whether cw or modulated jamming signals are used. The amount of noise present, both aural and visual, will vary as the strength of the jamming signal varies. The effects of barrage jamming are similar to those of spot jamming. If swept jamming (or swept frequency jamming) is encountered, it will produce sounds resembling a rushing wind coming and going and will cause a recurring brightening of the scope. Each time the jamming frequency, in its sweep, coincides with the radar frequency, the jamming indications will be evident. All types of jamming will have directional characteristics; that is, the jamming will be evident only, or most strongly, when the radar antenna is facing the direction of the jammer location. This directional characteristic, with proper operation of the radar controls, will permit identification of interference as jamming rather than natural or unintentional interference which normally does not possess directional characteristics.
- (2) *Reflection jamming.* Reflection jamming usually is produced by large numbers or quantities of small pieces of reflecting material that produce radar indications similar to large blocks of target returns.
- (3) *Transmission deception.* The most common type of transmission deception used against surveillance radars is "spoofing" (par. 33b (3)). The deception signals, usually

produced by a repeater type transmitter, produce radar indications that appear as a series or line of targets. In some cases, the signals may be identified as deception signals by their comparative perfection; that is, the uniformity of the intensity and spacing of the signals. If the radar operator has been thoroughly trained to recognize the various target indications normally encountered (personnel, tanks, trucks, etc.), he may be able to distinguish the aural indications of the deception signals from normal target indications. Also the movement, if any, of the deception signals also should differ greatly from that of real targets. The radar operators greatest aid in recognizing transmission deception is a thorough knowledge of both aural and visual indications of the various types of real targets.

- (4) *Reflection deception.* Reflection deception usually will be attempted by the use of a number of reflecting devices called angels. The most common type angel is a small but highly efficient corner reflector. A good deception device will produce a radar indication very similar to that of a real target. Again, the radar operator's greatest aid in recognizing and identifying reflection deception signals is a thorough knowledge of the indications, both aural and visual, of all types of targets.

36. Counter-Countermeasure (Antijamming) Operation

Since success of military operations may depend on information obtained by radar equipment, radar operators are called on to maintain operations during enemy countermeasure attacks. While not all AJ measures are the responsibility of the radar operator, he is responsible for doing everything within his capability to accomplish his mission. For example, if enemy countermeasures are used against the AN/TPS-25 while the radar is either searching for a target or tracking a target, the procedures given in *a* and *b* below may be used by the operator to reduce the effects of countermeasures he might encounter.

a. Search Mode AJ Operations. The following AJ measures should be employed when the radar set is under countermeasure attack in the search mode:

- (1) *Against jamming.*
 - (a) Select a narrower sector to scan.
 - (b) Adjust the receiver gain control (RCVR GAIN) to minimize the effects of the jamming. Also establish,

by use of this control, the direction from which the jamming is received.

- (c) Operate the set manually (MAN TRACK VIDEO operation) and, by observing where the jamming signal is strongest, locate the probable azimuth and elevation of the jamming source. Then return to search operation and try to locate targets on the edges of the jammed area as well as within the jammed area.
- (d) As soon as practicable (but not while the countermeasure attack is in progress), select a different radar site, preferably one which will afford a screening crest between the radar and the source of the jamming.
- (e) Keep the radar set on the air. No matter how severe the jamming, there is always a chance of locating targets in breaks in the jamming pattern.

(2) *Against deception.*

- (a) Observe carefully both the visual and aural indications of all targets. The regular strength and uniform spacing of the deception signals on the scope and the aural indications which will differ from those of known types of targets will help to identify the false targets.
- (b) Observe the indications of target movement. Familiarity with the motion of real targets of all types should permit identification of real targets as opposed to false targets.

b. Tracking Mode AJ Operation. When subjected to countermeasures while operating in the tracking mode, use the following AJ procedures:

(1) *Against jamming.*

- (a) Operating the set manually (MAN-TRACK AUDIO operation), adjust the AZIMUTH and ELEVATION cranks to maintain maximum amplitude of the audio display. A gentle rocking of these controls should help the operator to see the target through the jamming.
- (b) Adjust the RANGE crank for maximum audio amplitude on the scope display.
- (c) If the target becomes lost in the jamming, adjust the AZIMUTH, ELEVATION, and RANGE cranks to continue tracking at the same rate and in the same direction in which the target was moving prior to the interference. This may permit acquisition of the target when it moves out of the jamming cover.

- (d) Observing the target path on the plotting board also may aid in tracking through jamming since, for example a vehicle traveling on a road tends to remain on this road.
 - (e) Continue to track and DO NOT turn off the radar. A shutdown will inform the jammer crew that they are being effective.
 - (f) When practicable, site the radar so that a screening crest will protect the radar from jamming that may originate in areas that are not of primary interest.
- (2) *Against deception.*
- (a) Observe the appearance of target indications carefully. A transmission deception signal will maintain a constant strength, while real target indications tend to vary in strength with the movement of the target.
 - (b) In most cases, real target movement will be definite and purposeful where the indications of reflection deception devices probably will remain stationary or evidence erratic or random changes in range and azimuth.

37. Reporting and Recording

The existence of unidentifiable interfering signals should be reported immediately. This enables higher headquarters, through correlation of information from other units operating on various frequencies within a particular portion of the frequency spectrum, to determine whether or not countermeasures are actually being encountered. Prompt, accurate, and complete reporting of countermeasures reception is important. Properly correlated countermeasures information can give warning of impending enemy action in a sector or on a broad front and may provide intelligence on the extent and importance of such action.

a. Initial Report. When countermeasure signals are encountered, they must be reported immediately to higher echelon through the radar operator's immediate communication supervisor. Attempted, as well as successful countermeasures activity also should be reported. The operator must determine as quickly as possible and report the following:

- (1) The frequency being affected and the width of the frequency coverage of the countermeasure signal, if it can be established.
- (2) The type of countermeasure signal (transmission or reflection, jamming or deception) and the type of modulation, if any, when the signal is jamming.

- (3) The time and duration of the interference, including repetition, if any.
- (4) Signal strength and effect on radar operation, including the effect on other radars in the area if such sets can be contacted. Signal strength may be classified as strong, medium, or weak.
- (5) As accurately as possible, the direction both in azimuth and elevation to the origin of the countermeasure signal.
- (6) Unit, name, and grade of the operator making the report.

Note. The items in (1) through (6) above are suggested. Local standing operating procedures should designate the items to be included in the report and their order of priority.

b. Detailed Report. Immediately after the countermeasure attack occurs a detailed report of the reception of countermeasures will be made to the commanding officer by the person in charge of the radar station. The commanding officer will have the report processed through channels as required by the tactical situation.

c. Recording. When operating under countermeasure attack, the radar operator should keep a running record of events. The material for the record may be in the form of notes made by the operator or it may be a verbal account given by the operator to another crew member who, in turn, will make notes for the record. To be recorded are such things as: time of the initial reception of the interference; visual and aural indications of the countermeasure signals; means or operation used to determine type, strength, direction of origin, and effectiveness of the countermeasure signals; progressive steps taken to combat the countermeasures; and the results and effectiveness of each AJ measure as it is applied. Such information may be required for detailed reports, and will be valuable for future use by both operational and higher echelon personnel.

CHAPTER 8

DECONTAMINATION OF EQUIPMENT

38. General

Equipment which has been contaminated by chemical, biological, or radiological agents must be decontaminated in order to reduce the hazard to personnel. Decontamination can be done by covering, removing, destroying or changing into harmless substances the contaminating material. Personnel performing CBR decontamination should wear the mask, and normal clothing buttoned at the neck and tied at the wrists and ankles with string (trousers bloused). For added protection, personnel may wear any other protective items that are available. For details on decontamination see TM 3-220, TM 3-225, FM 10-69 and FM 21-40.

39. Chemical Decontamination

The best method for decontamination of radar equipment is by use of hot air; the next best method is by aeration or weathering. The metal parts exposed to blister and V-agents may be decontaminated with DANC solution; this must be carefully applied since it will affect insulation, promote corrosion and injure many plasters. DS2 is an excellent decontaminant for this equipment. Electrical devices which contain electron tubes or other heat producing units are normally decontaminated by the heat given off during operation.

40. Biological Decontamination

A decontaminant for destroying or removing contamination should be effective against a variety of biological agents. Items currently available are natural decontaminants and chemical decontaminants. Most decontaminants and procedures for chemical decontamination are effective for biological decontamination. Natural decontamination by rain, wind, and sunlight will destroy most biological agents on exterior of equipment within a day. Ethylene oxide or carbonide may be used to decontaminate the interior of equipment.

41. Radiological Decontamination

Decontaminants which have good cleansing characteristics are normally used for radiological decontamination because the contaminants for fallout are usually finely divided particles which adhere closely to materials and tend to settle into pores and crevices. In most military situations, radiological contaminants are satisfactorily removed by flushing with water, by the use of steam and by brushing. The use of DANC and DS2 procedures for chemical decontamination of equipment will also remove most radiological contamination. When speed is not an important factor, aging becomes the most desirable method since it will make laborious decontamination work unnecessary.

CHAPTER 9

DESTRUCTION OF EQUIPMENT

42. General

a. Tactical situations may arise in which it is necessary to abandon equipment in the combat zone. In such a situation all abandoned equipment must be destroyed to prevent its use by the enemy.

b. *The destruction of equipment subject to capture or abandonment in the combat zone will be undertaken only upon authority delegated by a division or higher commander.*

43. Principles

All sections will prepare plans for destroying their equipment in order to reduce the time required should destruction become necessary. The principles to apply are as follows:

a. Plans for destruction of equipment must be adequate, uniform, and easily carried out in the field.

b. Destruction must be as complete as the available time, equipment and personnel will permit. Since complete destruction requires considerable time, *priorities* must be established so that the more essential parts are destroyed first.

c. The same essential parts must be destroyed on all like units to prevent the enemy from constructing a complete unit from damaged ones.

d. Spare parts and accessories must be given the same priorities as the parts installed on the equipment.

44. Methods

To destroy equipment adequately and uniformly, all personnel of the unit must know the plan and priority of destruction.

45. Destruction

For detailed information on destruction of the radar set AN/TPS-25, see TM 11-5840-217-10.

CHAPTER 10

SAFETY PRECAUTIONS

46. Principles

Using personnel will not perform maintenance or inspections on the radar equipment beyond those specifically authorized in this manual and in the appropriate technical manual.

47. Precautions

a. Dangerous voltage is used in the operation of the radar equipment. Be careful when working on or near the 300-watt plate and power supply circuit or on the 115-volt AC line connections. *Extremely high voltages* exist in the following units:

Radar modulator MD-344/TPS-25	3,800 and 7,600 volts DC
Radar receiver-transmitter RT-500/TPS-25	750, — 760, 3,800 and 16,000 volts DC.
Radar set control C-2715/TPS-25	2,000 volts DC
Power supply PP-2166/TPS-25	845 volts AC
Servo data coordinator SN-231/TPS-25	1,000, 2,000 volts DC

b. The engine generator will not be refueled when the radar is transmitting, and gasoline containers in the vicinity of the radar set should not be handled or left open.

c. Radio frequency (RF) energy transmitted by the radar set can produce severe burns. Radiation levels extremely dangerous to personnel exist in the radar beam up to a distance of 40 feet from the antenna.

d. Radioactive material is contained in electron tube types TU-1271, OA2WA, 6627/OB2WA, and 5783WA used in the radar set. These tubes are potentially dangerous to personnel when broken. If handling personnel are cut by a broken tube, emergency medical attention is required. For specific instructions, see TB SIG 225.

e. Selenium rectifiers are used in the receiver-transmitter RT-500/TPS-25. Failure of these rectifiers can result in the liberation of poisonous fumes and the deposit of poisonous selenium compounds. If a rectifier burns out or arcs over, a strong odor is released. Provide adequate ventilation immediately.

Avoid inhaling the fumes and do not handle the damaged rectifier until it has cooled.

48. Electric Shock

Electric shock casualties may stop breathing. A casualty may recover if artificial respiration is applied promptly and efficiently. Principles and procedures for treatment of electric shock are described in FM 21-11.

CHAPTER 11

TRAINING

49. Purpose and Scope

The purpose of this chapter is to present the requirements for training the personnel of a radar section in the performance of their duties. It includes general information on the conduct of training.

50. Objectives

The objectives are to train radar crewmen rapidly in their individual duties and, through drill, to weld them into an effective, coordinated team able to function effectively in combat. Optimum efficiency is attained through frequent drills.

51. Conduct of Training

a. Training will be conducted in accordance with the principles set forth in FM 21-5. The goal of training should be the standards set forth in AR 611-201, and ATP 6-100.

b. Individual training is conducted by noncommissioned officers as far as practicable. Officers are responsible for preparing training plans, for conducting unit training, and for supervising and testing individual training.

c. Throughout training, the application of prior instruction to current training must be emphasized.

d. A record of the training received by each individual should be kept on a progress card by his chief of section. This card should show each period of instruction attended, tests taken, and remarks pertaining to progress. Progress cards should be inspected frequently by the radar officer to make sure that they are properly maintained and to determine the state of training. *Requiring the chief of section to keep these records emphasizes his responsibility toward his section.*

e. The necessity for developing leadership and initiative in noncommissioned officers must be emphasized constantly throughout training.

52. Standards to be Attained

Each member of a radar section must know the duties of other members of the section. Section personnel must be able to perform efficiently in all positions. This goal is attained by rotation of duties during training.

APPENDIX I

REFERENCES

1. Field Manuals

FM 5-15	Field Fortification.
FM 5-20	Camouflage, Basic Principles and Field Camouflage.
FM 5-25	Explosives and Demolitions.
FM 6-2	Field Artillery Survey.
FM 6-10	Field Artillery Communications.
FM 6-20-1	Field Artillery Tactics.
FM 6-20-2	Field Artillery Techniques.
FM 6-40	Field Artillery Cannon Gunnery.
FM 6-125	Qualification Tests for Specialists, Field Artillery.
FM 6-140	The Field Artillery Battery.
FM 10-69	CBR and Nuclear Protection and Decontamination of QM Supplies and Equipment.
FM 21-5	Military Training.
FM 21-11	First Aid for Soldiers.
FM 21-30	Military Symbols.
FM 21-40	Small Unit Procedures in Nuclear, Biological and Chemical Warfare.
FM 21-60	Visual Signals.
FM 22-5	Drills and Ceremonies.
FM 24-150	Electronic Warfare (U).
FM 25-10	Motor Transportation, Operations.

2. Technical Manuals

TM 3-220	Decontamination.
TM 3-225	Radiological Recovery of Fixed Military Installations.
TM 9-1900	Ammunition, General.
TM 9-2002	Launcher, Rocket, 3.5-Inch.
TM 9-2810	Tactical Motor Vehicle Inspection and Preventive Maintenance Service.
TM 9-8022	Truck, Cargo, 2½-Ton, 6x6.

TM 9-8030	Truck, Cargo, 3/4-Ton, 4x4.
TM 11-286	Radio Set, AN/VRC-9.
TM 11-467	Radar System Fundamentals.
TM 11-750	Radar Electronic Counter-Countermeasures for the Operator (U).
TM 11-5840-217-10	Operator's Manual, Radar Set AN/TPS-25.
TM 11-5840-217-20	Organizational Maintenance Manual: Radar Sets AN/TPS-25, AN/TPS-25A.
TM 11-6115-203-12	Gasoline Engine Generator Set PU-450/G. Operation and Organizational Maintenance.

3. Miscellaneous

AR 611-201	Enlisted Military Occupational Specialties.
AR 750-5	Maintenance Responsibilities and Shop Operation.
ATP 6-100	Army Training Program for Field Artillery Unit.
DA Form 468	Unsatisfactory Equipment Report.
DA Pam 310	Index of Military Publications.

INDEX

	Paragraphs	Page
Adjustment, preliminary-----	18	19
Antenna orientation-----	23	23
Antijamming operation-----	36	38
Battlefield surveillance, preliminary procedures-----	30	32
Biological decontamination-----	40	37
Calibration of counters-----	26	30
Cartesian coordinates-----	25	28
Checks, operational-----	20	20
Composition of radar section-----	5	4
Counter-countermeasures-----	34	35
Countermeasures:		
Electronic-----	33	34
Identification-----	35	36
Counters:		
Calibration-----	26	30
Orientation, X and Y-----	25	28
Decontamination:		
Biological-----	40	42
Chemical-----	39	42
General-----	38	42
Radiological-----	41	43
Destruction of equipment-----	42-45	44
Duties:		
Emplacement-----	14	10
General-----	6	4
March order-----	16	17
Electronic countermeasures-----	33	34
Emergency stopping procedures-----	22	23
Emplacement:		
General-----	13	10
Individual duties-----	14	10
Employment:		
Tactical considerations-----	9	7
Technical considerations-----	10	8
Equipment-----	2	2
First aid-----	48	46
General duties of personnel-----	6	4
Individual duties:		
Emplacement-----	14	10
March order-----	16	17

	Paragraphs	Page
Jamming.....	33-37	34
Map and plotting board orientation.....	24	25
March order, individual duties.....	16	17
Modes of operation:		
Battlefield surveillance.....	31	32
Moving ground target detection.....	32	33
Normal stopping procedures.....	21	22
Operational checks.....	20	20
Organization:		
General.....	4	4
Radar site.....	12	10
Orientation:		
Antenna.....	23	23
Map and plotting board.....	24	25
X and Y counter.....	25	28
Personnel:		
General duties.....	6	4
Utilization of.....	28	31
Plotting board orientation.....	24	25
Precautions, safety.....	46-48	45
Preliminary adjustments.....	18	19
Preoperation and performance checks.....	17-26	19
Procedures:		
Battlefield surveillance and moving ground target detection.....	30	32
Starting.....	19	20
Reporting and recording enemy jamming.....	37	40
Safety precautions.....	46-48	45
Selection of site.....	8	6
Starting procedures.....	19	20
Stopping procedure:		
Emergency.....	22	23
Normal.....	21	22
Tactical considerations in employment.....	9	7
Technical considerations in employment.....	10	8
Training.....	49-52	47
Utilization of personnel.....	28	31

BY ORDER OF THE SECRETARY OF THE ARMY:

G. H. DECKER,
General, United States Army,
Chief of Staff.

Official:

J. C. LAMBERT,
Major General, United States Army,
The Adjutant General.

Distribution:

Active Army:

DCSPER (2)	USCONARC (5)
ACSI (2)	Armies (5)
DCSLOG (2)	Corps (3)
DCSOPS (2)	Corps Arty (2)
ACSRC (2)	Div (3)
CRD (2)	Bde (2)
COA (1)	BG (1)
CINFO (1)	USAWC (1)
TIG (1)	USASCS (10)
TJAG (1)	USAAMS (1400)
TPMG (1)	Units org under fol TOE
Tech Stf, DA (1) except	(5 cy ea)
CSigO (2)	6-101
CCmLO (2)	6-201
ARADCOM (2)	6-301
ARADCOM Rgn (2)	6-302
LOGCOMD (1)	

NG: None.

USAR: Same as Active Army except allowance is one copy to each unit.
For explanation of abbreviations used see AR 320-50.

☆ U. S. GOVERNMENT PRINTING OFFICE: 1962-610521

3000015769

