

FM 55-43

Copy 2 S/S by FC 1-54

unclassified/wi m
filed crest

MARTIN-BAKER

MK-J5D

EJECTION SEAT

SEPTEMBER 1982

FM 55-43

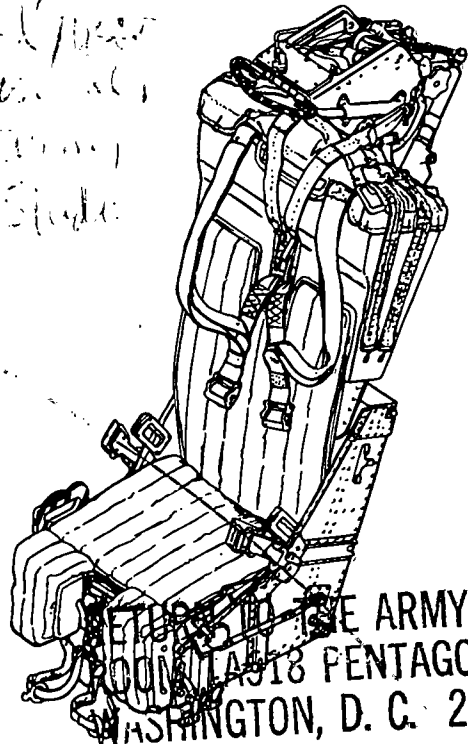

THE ARMY LIBRARY
1318 PENTAGON
WASHINGTON, D. C. 20310

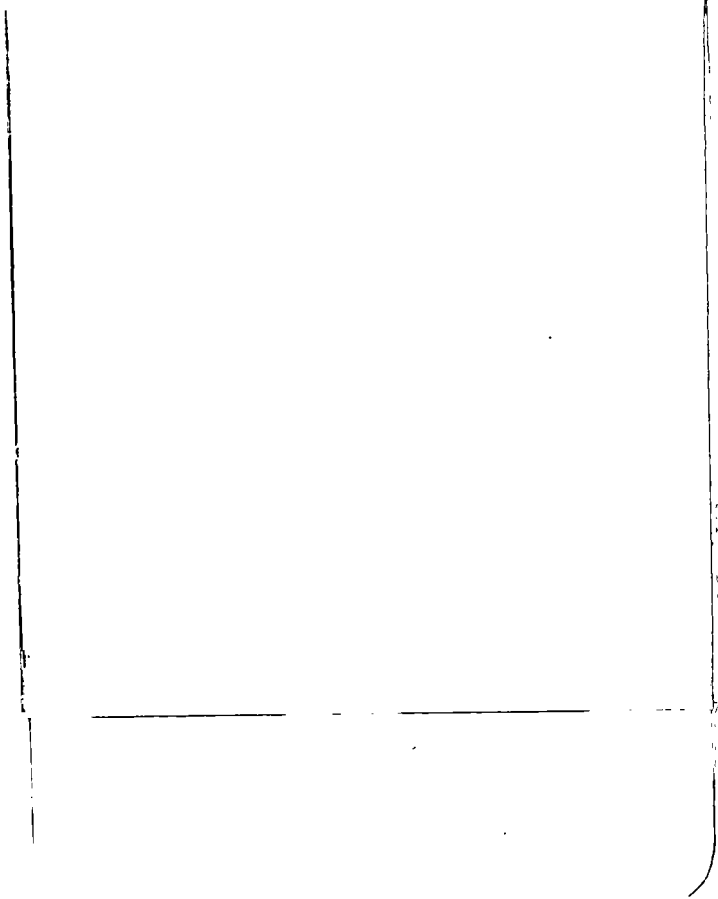

S/S by FC 1-543 ; December 1985

FIELD MANUAL
NO 55-43

unclassified/limited/USGO not done
also Army studies

FM 55-43

HEADQUARTERS
DEPARTMENT OF THE ARMY
WASHINGTON, DC, 3 SEPTEMBER 1982

MARTIN-BAKER MK-J5D EJECTION SEAT

PREFACE

This field manual provides information for all personnel who require familiarization or technical training on the MK-J5D Martin-Baker ejection seat system. It also provides a guide for standardizing unit and individual training on the system. AR 95-1 (Army Aviation: General Provisions and Flight Regulations) directs that training requirements herein be completed by OV-1 (Mohawk) aircraft members, maintenance personnel, and passengers prior to flight in or maintenance on the aircraft. This manual gives individuals a capsule view of the seat system, its operation and servicing, and safety and caution areas.

The OV-1 (Mohawk) operator's manual, TM 55-1510-213-10, and the MK-J5D Martin-Baker ejection seat maintenance manual, TM 55-1680-308-24, were used extensively as references for developing this manual and should be referred to by aviator and maintenance personnel. However, this manual illustrates critical tasks in an easy-to-understand sequence and further assigns responsibilities for training and required frequency of training. The best practical ejection seat training available can be obtained by using this field manual in conjunction with the ejection seat simulator.

Users of this field manual are encouraged to recommend changes or provide comments to improve it. Comments should be keyed to the specific page, paragraph, and line of text in which the change is recommended. Reasons should be provided for each comment to insure understanding and complete evaluation. Comments should be prepared using DA Form 2028 (Recommended Changes to Publications and Blank Forms) and forwarded to the Commandant, US Army Transportation School, ATTN: ATSP-TD-TL, Fort Eustis, Virginia 23604.

The words “he,” “him,” “his,” and “men,” when used in this publication, represent both the masculine and feminine genders, unless otherwise specifically stated.

TABLE OF CONTENTS

CHAPTER 1	THE TRAINING PROGRAM	4
2	SEAT DESCRIPTION	13
3	SAFETY PRECAUTIONS	25
4	EJECTIONS	30
5	MANUAL AND EMERGENCY PROCEDURES	41
6	INSPECTIONS	51
7	EJECTION SEAT SIMULATOR	54
APPENDIX	REFERENCES	59
INDEX	61

CHAPTER 1

THE TRAINING PROGRAM

WHO NEEDS TRAINING?

All individuals with a foreseeable “need to know” should be thoroughly trained on the operation and safety features of the MK-J5D Martin-Baker ejection seat. Commanders controlling aviation assets which use the ejection seat are responsible for training on the system. The following personnel must be trained:

- OV-1 crew members (96H/17L).
- Aircraft maintenance officers.
- OV-1 mechanics (67H).
- OV-1 crew chiefs (67H).
- Fixed-wing technical inspectors (66H).
- Medical personnel involved in crash rescue missions.
- OV-1 enginemen (68B).

REASONS FOR TRAINING

The MK-J5D Martin-Baker ejection seat training program is designed to provide personnel with an in depth coverage of the entire seat, including the survival equipment contained therein, and to train them in its use. Following are some of the primary reasons for this training:

More successful escapes. Scientific studies on escape procedures indicate that well-trained personnel will save more lives, make more successful escapes, and incur fewer injuries than those who have less training.

Self-confidence. Personnel who are well trained in escape procedures develop the self-confidence needed to execute them if necessary. If the training program is properly supervised and the quality of instruction is maintained at a high level, each individual trainee will gain a thorough knowledge of the ejection seat system. During an actual emergency, chances for survival are increased immeasurably when individuals know all the procedures and have the self-assurance that they can perform them if required. Self-confidence in the system will also allow individuals to concentrate on other unrelated emergency procedures which may preclude the need to eject.

Standardization. Ejection seat training should be standardized to insure a uniform program. Thorough initial training, followed up by periodic review and practice, will aid memory retention and insure desired automatic reactions. Standardization in training programs insures that crew members can rely on one another to react properly during actual emergencies. It also allows time for other emergency procedures such as position orientation and planning the rescue or escape efforts.

Maintenance, rescue, and aviation life support equipment (ALSE) personnel, the ultimate specialists who insure safety during maintenance and rescue operations, must maintain the same detailed training standards as crew members. Training courses should be established at the lowest levels so that high training standards can be constantly stressed during all ejection seat training.

Disciplined actions. Actual escape procedures cannot be completely rehearsed; however, well-trained individuals will know what to expect and will be more capable of maintaining their composure during an actual emergency where ejection is unavoidable. During crash operations, the well-trained individual who knows his job is the key to successful extraction of crew members from the aircraft. Thorough training will help to establish a disciplined safety-conscious attitude that will save lives and prevent serious injuries during all operations on or around the ejection seat system.

REQUIRED TRAINING

Initial and annual training requirements on the operation and safety procedures of the MK-J5D Martin-Baker ejection seat are shown in the following table.

Annual Ejection Seat Refresher Training Requirements			
Areas of Emphasis	OV-1 crew chiefs	OV-1 aviators, observers, passengers, and medical personnel	Other OV-1 maintenance personnel
Description and familiarization	1½ hr	1½ hr	1½ hr
Normal (automatic) ejections	½ hr	½ hr
Parachute technique	½ hr	½ hr
Parachute landing techniques	Practical exercises	Practical exercises
Emergency operations	½ hr	½ hr
Daily maintenance inspection	1 hr
Aviator's preflight check	1 hr
Safety precautions for crew chiefs and other maintenance personnel	½ hr	½ hr
Safety precautions for aviators	½ hr
Proper harness adjustments and seating	Demonstration	Demonstration
Ejection drill	Practical exercises	Practical exercises
Ejection in the ejection seat simulator	One successful ejection (initial training only)	One successful ejection (initial training only)

TRAINING RESPONSIBILITIES

The following US Army Training and Doctrine Command (TRADOC) schools provide training in the MK-J5D Martin-Baker ejection seat operation:

The US Army Transportation School, Fort Eustis, Virginia, is responsible for initial ejection seat instruction for students attending the following courses:

- Aircraft Maintenance Officers' Course.
- Fixed-Wing Technical Inspectors' Course.
- All aircraft maintenance specialized courses.

The US Army Aviation School, Fort Rucker, Alabama, is responsible for initial ejection seat instruction for aviators attending the OV-1 (Mohawk) Aviator Transition Course and for OV-1 aviators, observers, crew chiefs, passengers, and maintenance and medical personnel assigned to Fort Rucker.

The US Army Intelligence School/Training Center, Fort Huachuca, Arizona, is responsible for initial ejection seat instruction for OV-1 airborne sensor specialists and passengers assigned to Fort Huachuca.

Upon successful completion of ejection seat training, appropriate records will be completed for each individual as specified in AR 95-1.

**FOR CREW MEMBERS--DA FORM 759,
INDIVIDUAL FLIGHT RECORD AND
FLIGHT CERTIFICATE - ARMY**

**FOR OTHERS LISTED--DA FORM 3015,
FLIGHT EQUIPMENT TRAINING RECORD**

TRAINING PREREQUISITES

Individuals must be physically fit prior to being ejected in the MK-J5D Martin-Baker ejection seat simulator. Written medical approval of a doctor of medicine is required for any individual having a record of back, head, neck, or hemorrhoid injury.

Waivers for training may be granted according to AR 95-1. If an individual does not qualify physically, as stated above, but still has a need to be trained on the seat, commanders may waive the actual firing phase of the training. However, crew members must complete the entire ejection seat training.

SEAT DESCRIPTION

SEAT SIDE BEAM ASSEMBLY

The seat side beam assembly (1) is the primary framework upon which additional major components are mounted. The assembly consists of two vertical side beams fixed in position by three crossbeams (2).

Top crossbeam. The top crossbeam joins the top ends of the main beams. It is a one-piece, cup-shaped fitting with an opening in the top that enables the upper portion of the ejection gun inner tube to protrude. The flange on the inner tube cannot pass through this opening. As the inner tube rises on ejection, it bears against the top crossbeam to transmit the thrust of the ejection gun and lift the seat and the occupant from the airplane. The top crossbeam also mounts the restraining scissor for the drogue shackle.

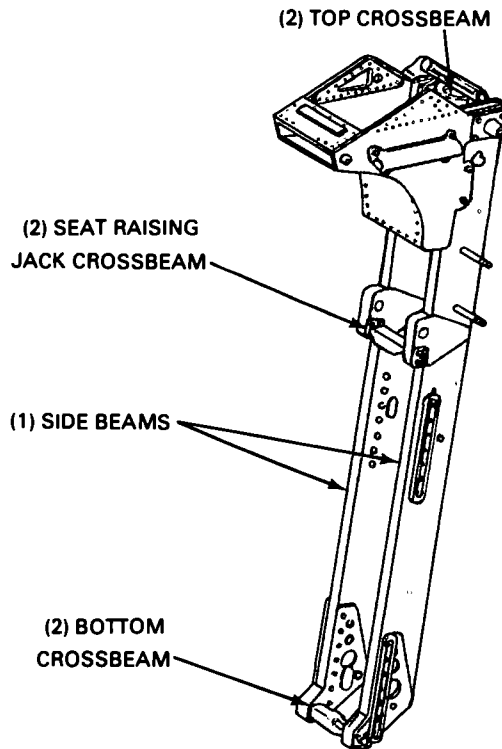

FM 55-43

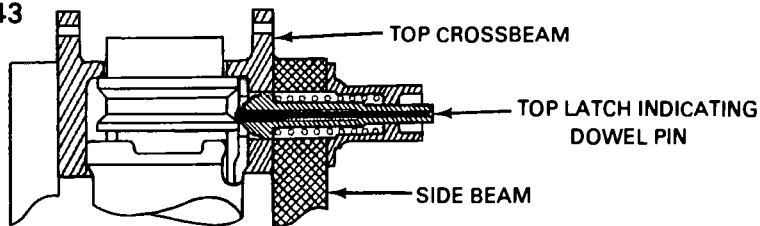

INCORRECT ENGAGEMENT
SEAT UNLOCKED FROM EJECTION GUN —TOP LATCH PLUNGER DIS-ENGAGED FROM PRIMARY CARTRIDGE BREECH GROOVE AND OUTER TUBE SLOT.

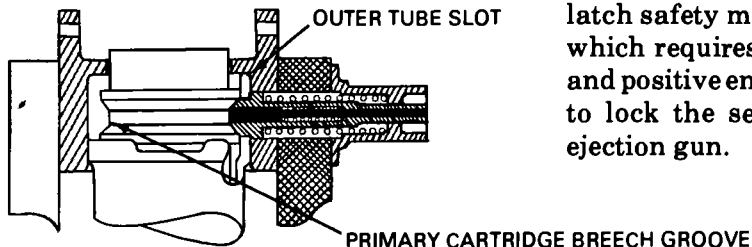

CORRECT ENGAGEMENT
SEAT LOCKED TO EJECTION GUN — TOP LATCH PLUNGER ENGAGED IN PRIMARY CARTRIDGE BREECH GROOVE AND OUTER TUBE SLOT.

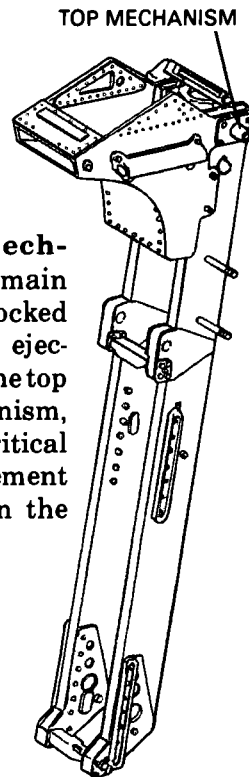

Top latch mechanism. The seat main beam assembly is locked in position on the ejection gun barrel by the top latch safety mechanism, which requires a critical and positive engagement to lock the seat on the ejection gun.

DROGUE GUN

The drogue gun is mounted on the upper portion of the left vertical side beam. The purpose of the drogue gun is to extract the 5-foot drogue parachute, which is housed in a container on top of the ejection seat. After the drogue gun fires (A), a piston is propelled from the drogue gun which extracts the drogue parachute (B). The drogue parachute and drogue shackle are held in place until released by the time-release mechanism; after release, the pull is transmitted to the drogue parachute (C) through a link line which extracts the main personnel parachute (D).

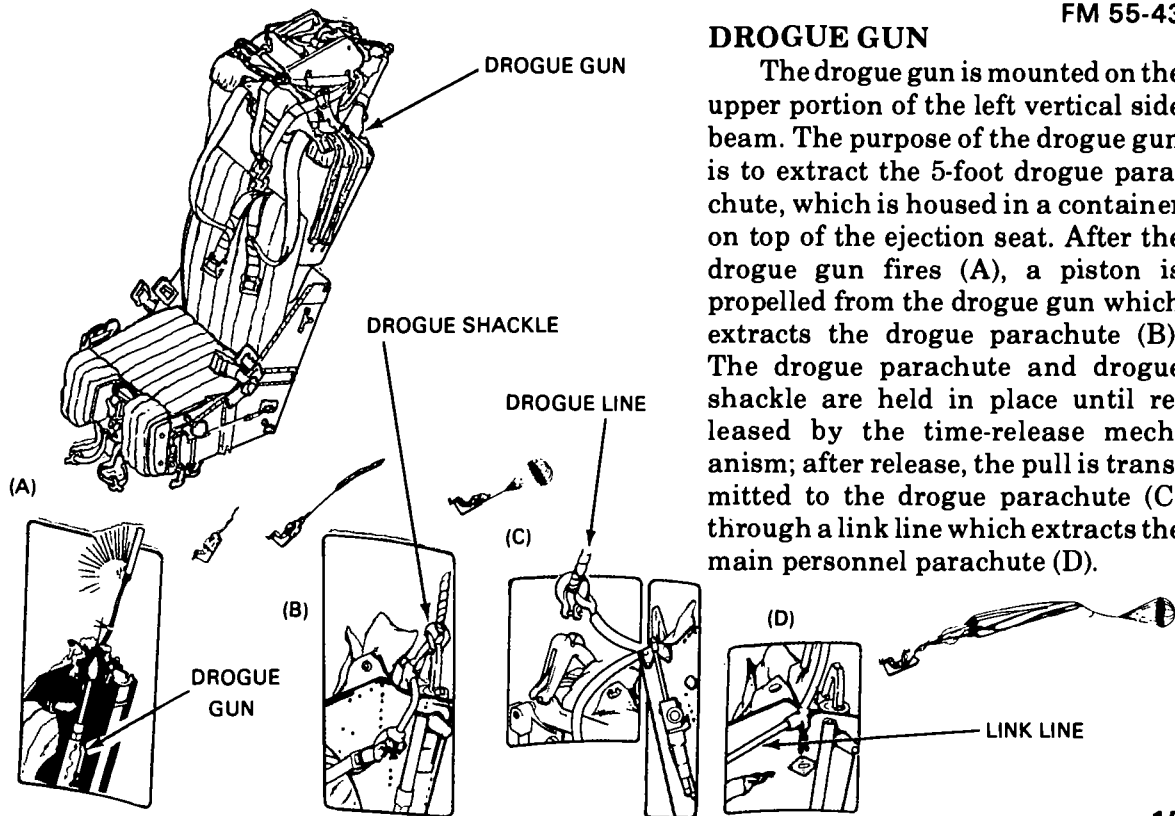

TIME-RELEASE MECHANISM

The time-release mechanism is mounted on the upper portion of the right side beam. It provides a time delay of 1.65 to 1.85 seconds after the ejection seat has started to rise before allowing the scissor shackle to release the 5-foot drogue parachute from the seat. A barostat mounted on the time-release mechanism prohibits the separation of occupant and seat above 15,500 feet. The time-release mechanism also accomplishes the following simultaneous actions by mechanical linkage: It allows the restraining scissor on the ejection seat to open, releasing the drogue parachute which deploys the personnel parachute, and also releases the occupant restraint points, freeing the occupant from the ejection seat and enabling a safe descent by parachute.

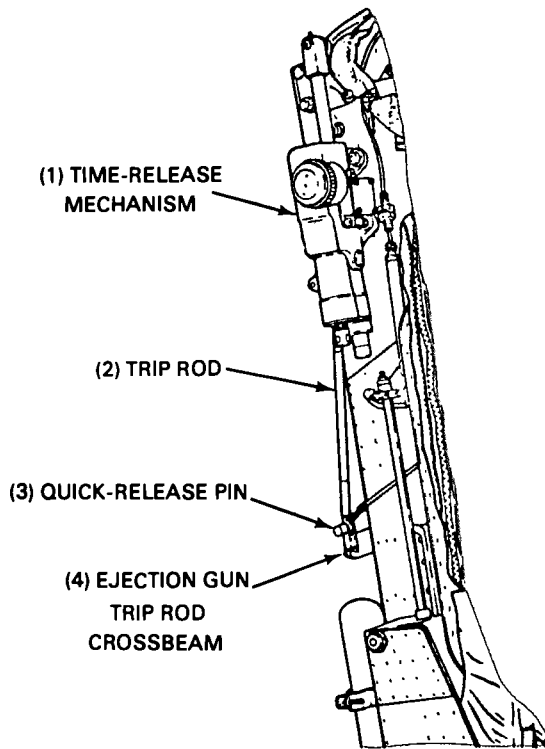

FIRING MECHANISM

The firing mechanism is threaded into the top of the inner telescoping tube and locks the inner tube retainer in place. It consists of a body, compression spring, sear, and firing pin. The wedge-shaped sear is retained in a slot in the top of the firing pin. When the sear is pulled out of the slot, by pulling the face blind firing cable or the lower firing cable, the firing pin spring will cause the firing pin to strike the primary cartridge, starting the ejection process.

The outer tube (ejection gun barrel) is attached to the cockpit floor and sloping bulkhead; it houses the upper and lower auxiliary cartridges. Guide rails (or tracks) on each side of the outer tube provide for proper alignment of the seat during installation and initial seat travel upon ejection.

Quick-release pins connect the drogue gun and the time-release mechanism trip rods to the the ejection gun trip rod bracket.

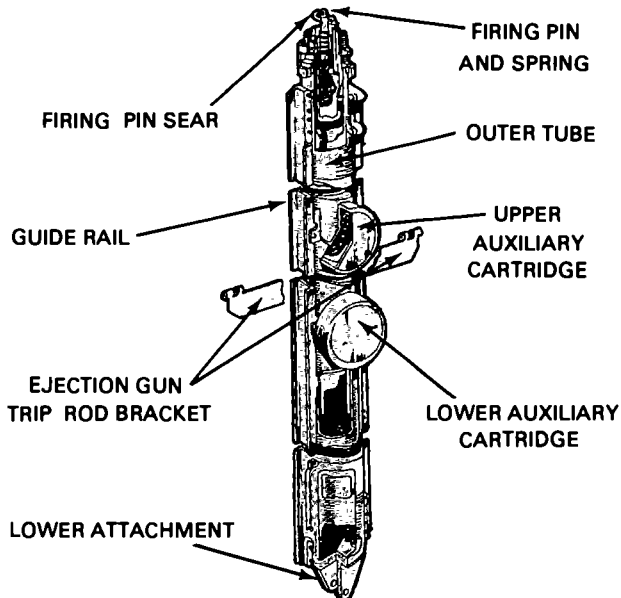

When the primary cartridge is fired (A), the inner tube is forced by the pressure of the generated gases to rise together with the intermediate tube.

The initial movement of the inner tube unlocks the seat by camming the spring-loaded plunger out of the primary cartridge breech groove and outer tube slot.

The inner tube assembly continues to rise through the ejection sequence, forcing the ejection of the seat and occupant.

After a movement of 14 inches, a port is uncovered which enables the pressure and heat to ignite the lower auxiliary cartridge (B).

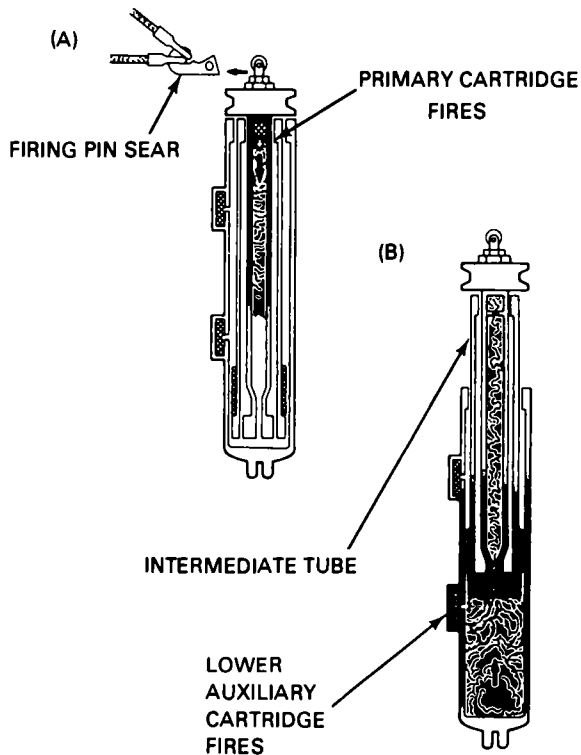

After a total movement of 31 inches, the other port is uncovered and the upper auxiliary cartridge is ignited (C).

UPPER AUXILIARY
CARTRIDGE IGNITES



The two tubes continue rising until the intermediate tube, having extended to its 39-inch stroke, is stopped by a flange on the barrel, the shock being cushioned by 12 gas-filled pressure rings (D).

PRESSURE RINGS



The inner tube continues rising from its 33-inch stroke still carrying the seat until it finally leaves the intermediate tube; the piston strikes the inner tube guide bushing (E).

PISTON STRIKES
INNER TUBE
GUIDE BUSHING

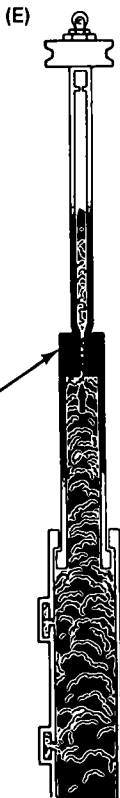

Shearing off the rivets of the guide bushing, the power of the charges propels the occupant and seat up and out of the aircraft (F).

SHEARING OFF THE
RIVETS OF THE
GUIDE BUSHING

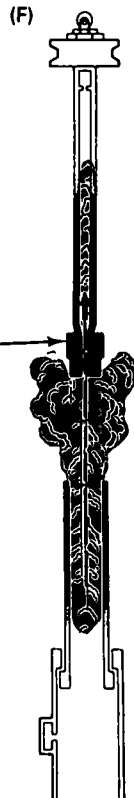

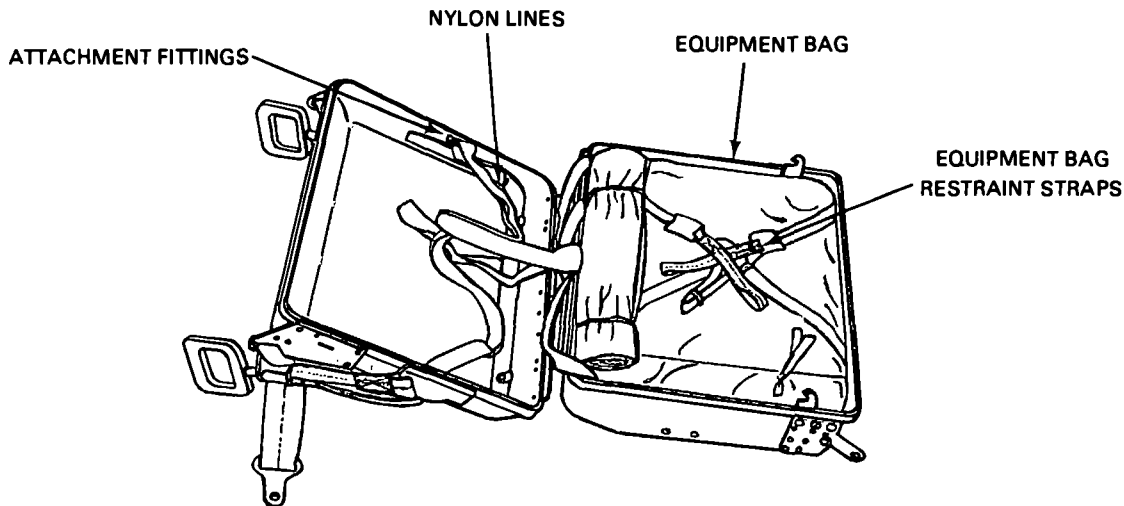

THE RIGID SEAT SURVIVAL KIT

Attached to the occupant's parachute harness is the seat survival kit, which also acts as a seat during parachute descent. The survival kit is housed in a fiberglass case. To open the case and release the survival kit, the occupant must squeeze and pull either survival kit grip. The three types of survival kits include hot climate, cold climate, and over water. Refer to TM 55-8465-212-10, TM 55-8465-213-10, and TM 55-8465-214-10 for contents of these kits as well as servicing.

THE AUTOMATIC EMERGENCY OXYGEN SYSTEM

The emergency oxygen bottle, located on the right side of each seat, supplies about 10 minutes of oxygen to the occupant upon ejection, regardless of altitude, and is actuated during the initial upward movement of the seat.

When the occupant separates from the seat, a lanyard attached to the right retention harness assembly pulls on the quick-disconnect fitting to disengage the hose from the seat. Since this separation does not occur until a safe altitude is reached on descent, the occupant is furnished enough oxygen during high altitude ejections until a dense altitude is reached and the emergency oxygen is no longer needed.

A manually actuated green knob (called the "green apple") located on the right side of the seat bucket is connected to the actuating bellcrank by a cable. This knob provides a means of selecting the emergency oxygen system in lieu of the regular oxygen system of the airplane. Pulling on this knob will result in deflection of the bellcrank and activation of the ejection seat oxygen system. A pressure gage on the stem of the bottle indicates the quantity of oxygen remaining in the bottle. (The bottle is charged with oxygen at 1,800 to 2,000 psi at a temperature of 25° C (77° F).)

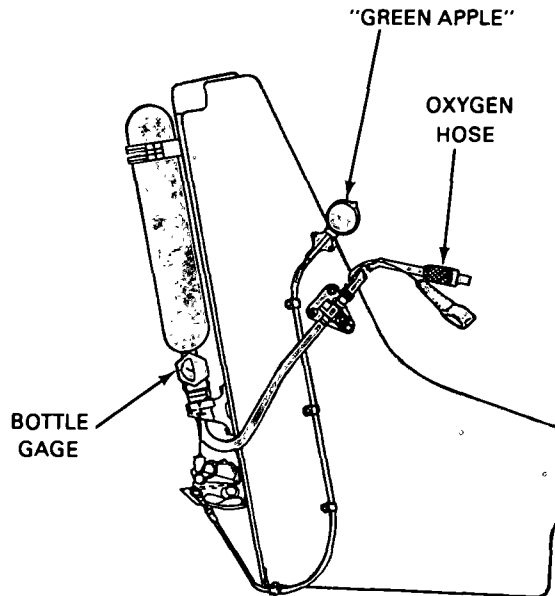

SEAT HEIGHT ADJUSTMENT SWITCH

When the seat height adjustment switch is pushed forward, it lowers the ejection seat by activating the seat-actuating jack mechanism. When the seat height adjustment switch is pulled aft, the ejection seat is raised. The switch is spring loaded and will return to the center (neutral) position when released. The total vertical travel capability of the MK-

J5D ejection seat is 4.7 inches. A white line is painted on the side of the ejection seat at eye level to guide the occupant in adjusting seat height.



WARNING: Do not operate the seat raising actuator more than 1 minute (max) during any 8-minute period of time. Extended operation will shorten the seat raising actuator service life.

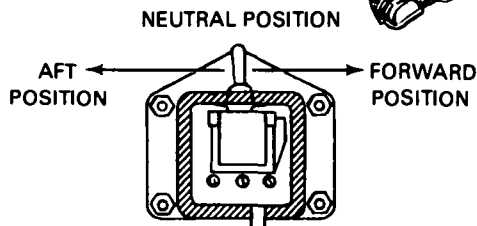

CHAPTER 3

SAFETY PRECAUTIONS

GENERAL

Safety precautions must be strictly observed when working in and around the cockpit of an aircraft equipped with Martin-Baker MK-J5D ejection seats. Only authorized personnel are permitted to work on the seat, and work must be performed in an authorized area.

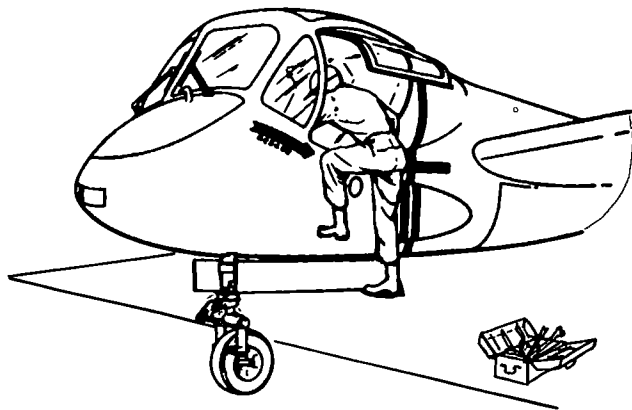

WARNING: Accidental operation of the firing mechanism in the ejection gun or drogue gun can result in death or serious injury to any persons leaning over the cockpit or standing near the airplane.

INSTALLING GROUND SAFETY PINS

Seven safety pins attached to the ends of a ground safety lock are provided for each seat and must be inserted when the airplane is on the ground. The ground safety lock consists of safety pins and one positioning (bucket pin) clip. The safety pins provide protection against the inadvertent firing of any charges in the ejection seat. Sequence for safety pin installation follows on the next two pages.

WARNING: Never remove the safety pins or the ground safety lock assembly unless preparing the aircraft for a mission or performing authorized maintenance on components of the ejection seat requiring removal of safety pins.

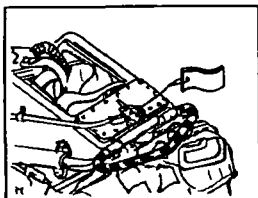

②

PLACE PIN IN FACE BLIND
LOCKING MECHANISM

①

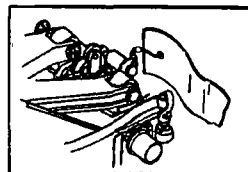

PLACE PIN IN EJECTION
GUN FIRING PIN SEAR

③

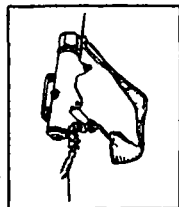

PLACE PIN IN
DROGUE GUN
LOCKING PIN

④

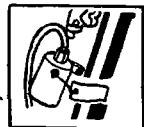

PLACE PIN IN
TIP-OFF COMPENSATING ROCKET DISPENSER

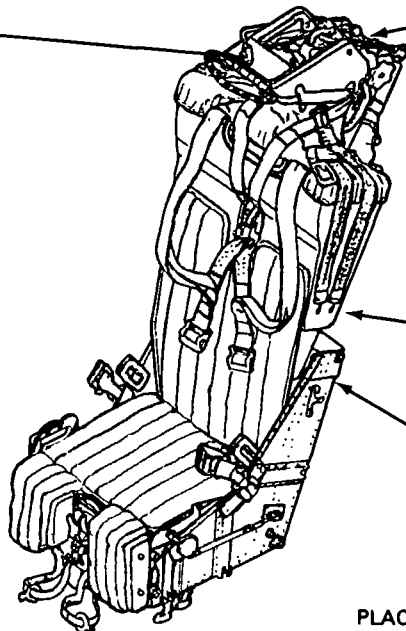

WARNING: Keep head clear of drogue gun projectile path while removing or installing pins.

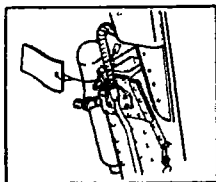

5

PLACE PIN IN
BUCKET PIN

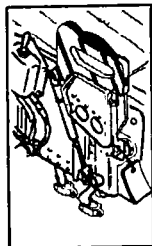

6

PLACE PIN IN MANUAL
OVERRIDE HANDLE

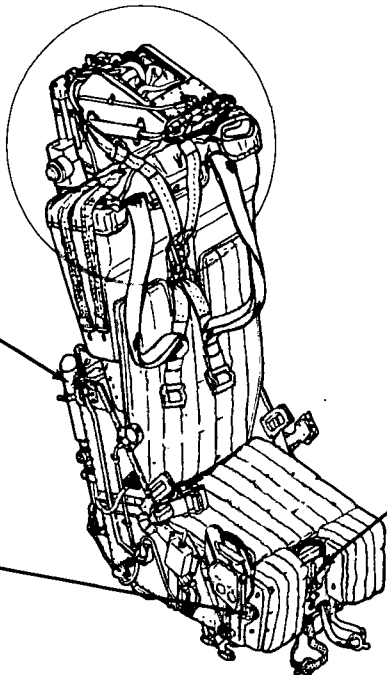

7

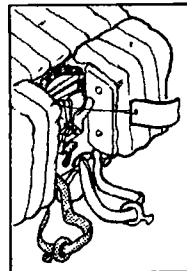

PLACE PIN IN
LOWER FIRING
HANDLE

Ground safety pins will be removed by reversing the above sequence.

PRECAUTIONS PRIOR TO SERVICING THE SEAT

FM 55-43

If extensive servicing of the seat is required, it is mandatory to remove the ejection seat, guillotine initiator cartridge, primary cartridge, and drogue gun cartridge. After removal, store cartridges as specified in TM 9-1300-206, Ammunition and Explosive Standards.

WARNING: Before proceeding with the investigation of an aircraft accident or incident, make sure the ejection seat safety pins are installed. If the seat has been separated from the aircraft, have a qualified seat person remove the seat cartridges before continuing investigation.

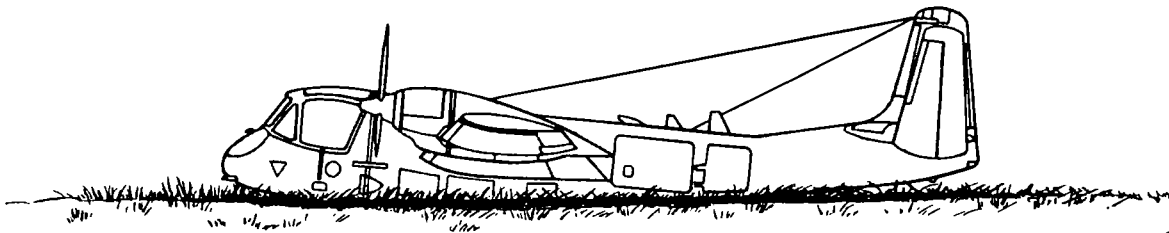

CHAPTER 4 EJECTIONS

EJECTING THROUGH CANOPY

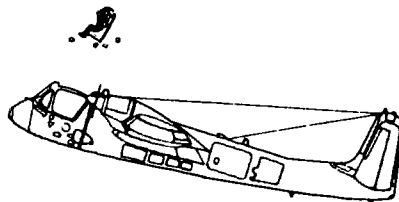

JETTISON THE CANOPY

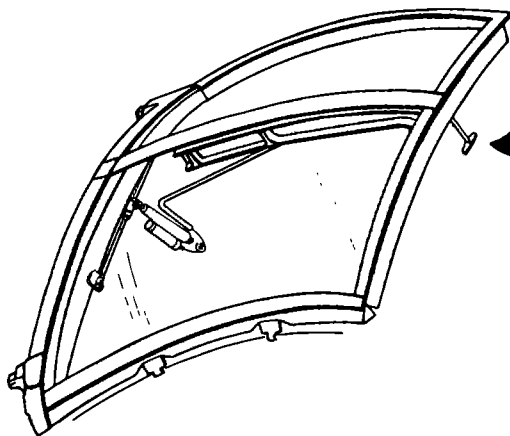
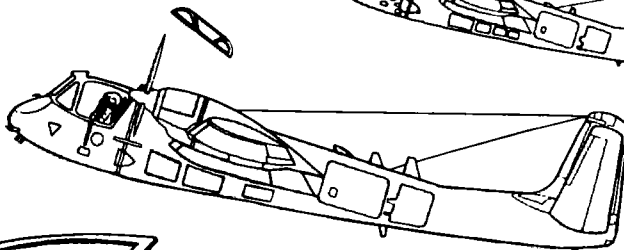

JETTISON HANDLE

INTRODUCTION

The primary means of escape is to eject through the escape hatch cover (canopy). Time permitting, the aircraft is placed in a shallow climb and the overhead canopy is jettisoned by rotating the jettison handle 90° in a clockwise position.

EJECTION COMMAND AND SIGNAL

The aviator is responsible for communicating to the crew member/passenger the decision to eject. The aviator's command is "EJECT." If radio communication in the cockpit is lost, or crew members/passengers, are unable to act, the acceptable signaling procedure is for the aviator to strike the individual on the chest. The established procedure is that the observer/passenger ejects first.

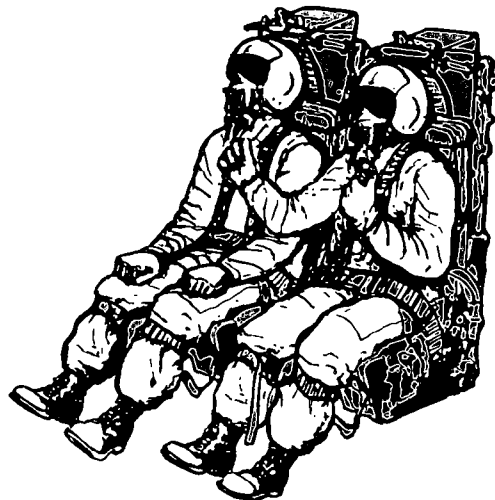

CREW MEMBER/PASSENGER EJECTS FIRST

PULL FACE BLIND
HANDLE FIRST.



HOLD FACE BLIND;
PULL LOWER
HANDLE



EJECTION BY PULLING THE FACE BLIND HANDLE

The body is positioned with the head held back against the headrest. Legs are extended forward to insure contact of the bottom of the thighs with the seat cushion. The face blind handle is grasped over the head with both hands, palms down; then the blind is pulled sharply out and down over the helmet and face. When pulling the face blind handle the occupant must keep his elbows as close to his body as possible to prevent injury.

EJECTION BY PULLING THE LOWER FIRING HANDLE

If pulling the face blind handle does not eject the seat, leave one hand grasping the face blind handle and pull the lower firing handle with the free hand. Inadvertent release of the face blind in this situation could cause facial injury because of face blind flailing in the wind upon ejection; also, release of the face blind with both hands will allow it to trail over the drogue parachute pack and may cause fouling of the drogue parachute system during deployment.

AUTOMATIC OPERATION

For occupants to safely eject, the aircraft must have attained a speed of at least 60 knots. Ejection can take place from ground level to maximum ceiling of the aircraft.

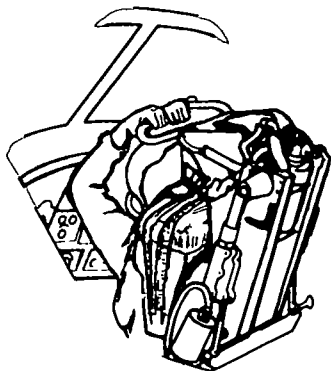
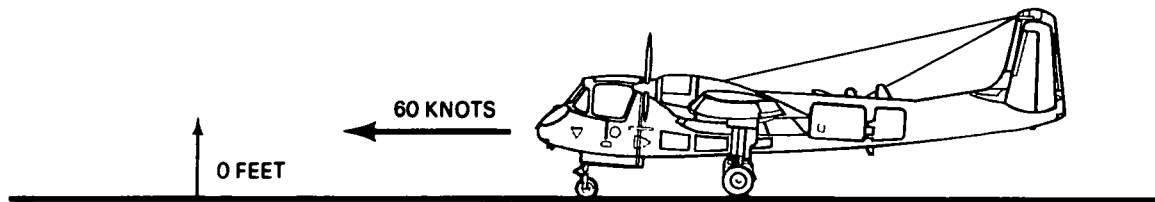

The operation of the ejection seat is divided into four phases. Ejection is initiated when the occupant pulls the face blind handle or the lower firing handle.

This action withdraws the primary firing pin sear from the firing mechanism in the ejecting gun. Withdrawal of the sear allows the firing pin to strike the primary cartridge in the ejecting gun tube, initiating the ejection sequence.

Phase I, clearing the airplane safely. As the seat moves upward, five separate events are initiated. The drogue gun sear is pulled from the gun by a trip rod attached to the ejection gun crossbeam; the time-release mechanism sear is pulled from the mechanism by a trip rod which is also attached to the ejection gun crossbeam; dual leg restraint

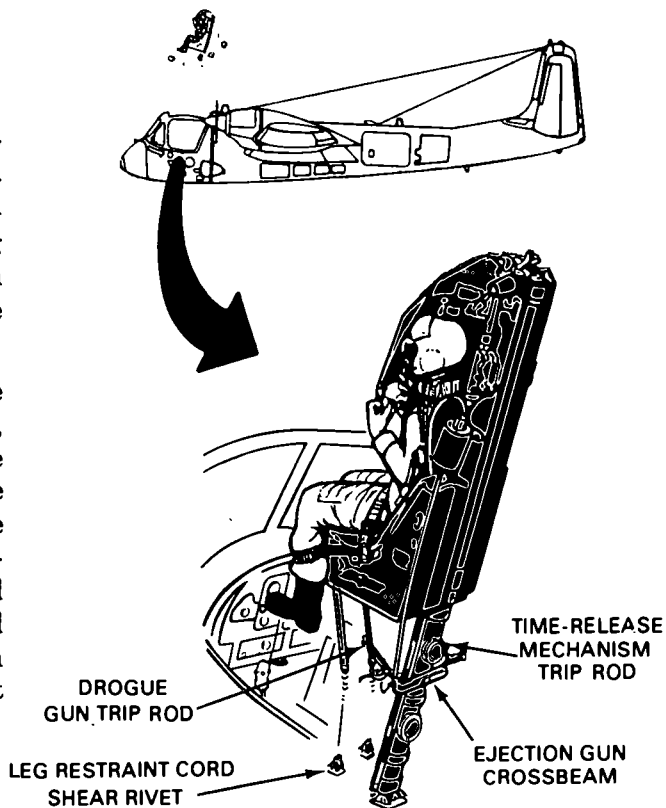

cords tighten, pulling the occupant's legs aft and together against the seat bucket to prevent injury as the ejection seat leaves the flight compartment; the emergency oxygen system

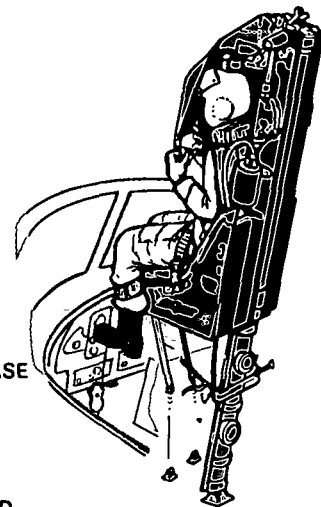
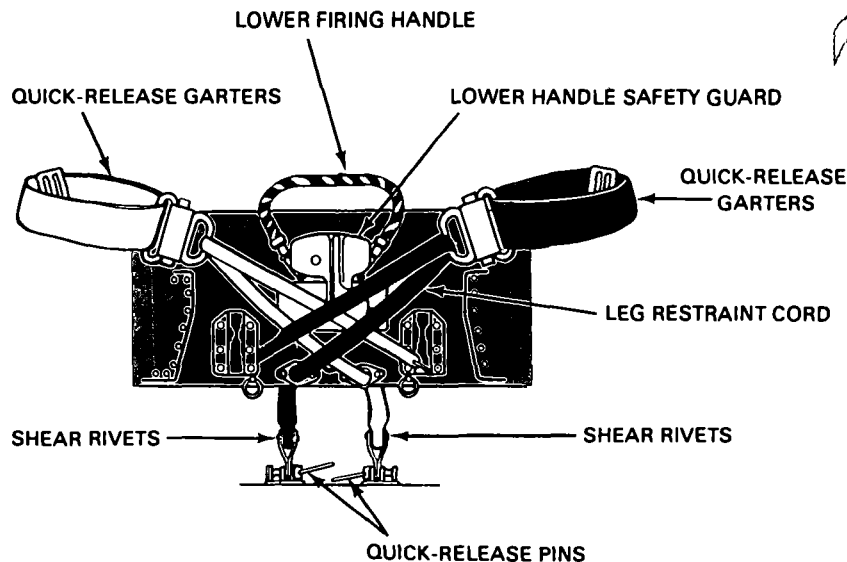

is activated, whether needed or not; and the tip-off compensating rocket fires after the seat has risen to within 9 inches of full ejection gun extension. The tip-off compensating rocket positions the ejection seat in the correct attitude for rapid unrestricted deployment of the drogue parachute and increases seat trajectory height.

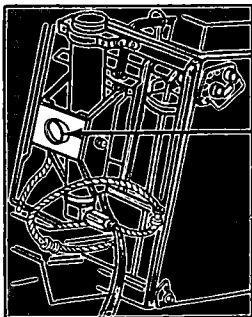

TIP-OFF
COMPENSATING
ROCKET

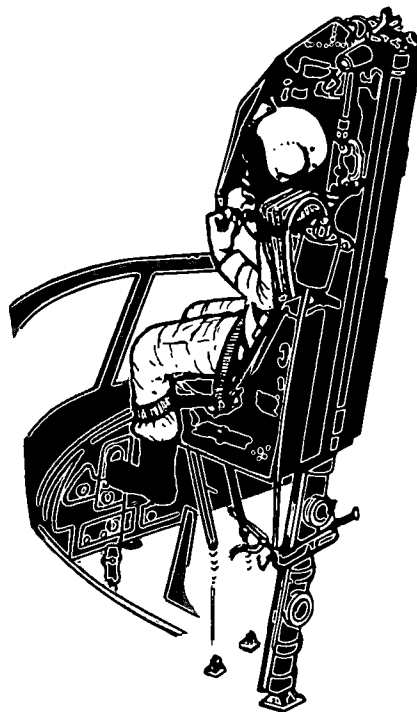

Phase II, stabilization and deceleration of seat and occupant. During ejection the occupant is held securely in the seat by the loop strap, parachute harness, lapbelt and survival kit assembly, and leg restraints. After the tip-off compensating rocket has positioned the seat, the drogue gun fires, forcibly extracting the 5-foot drogue parachute.

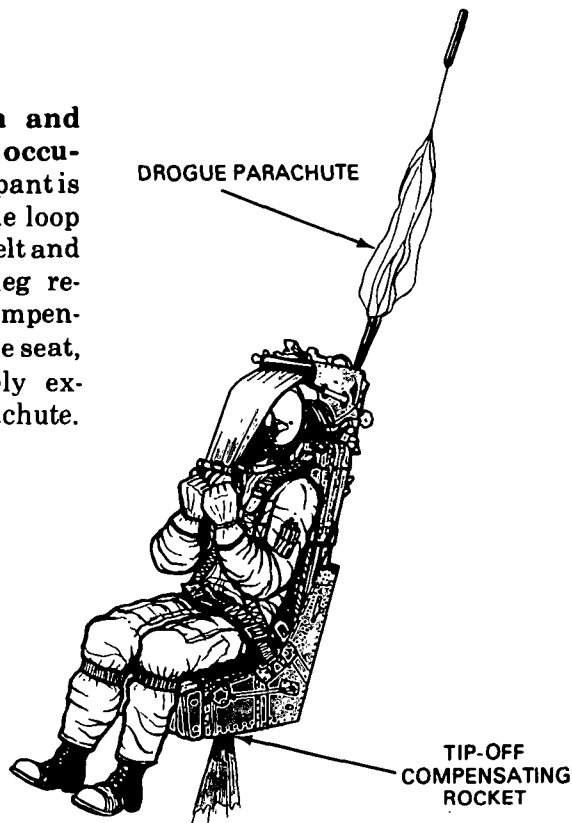

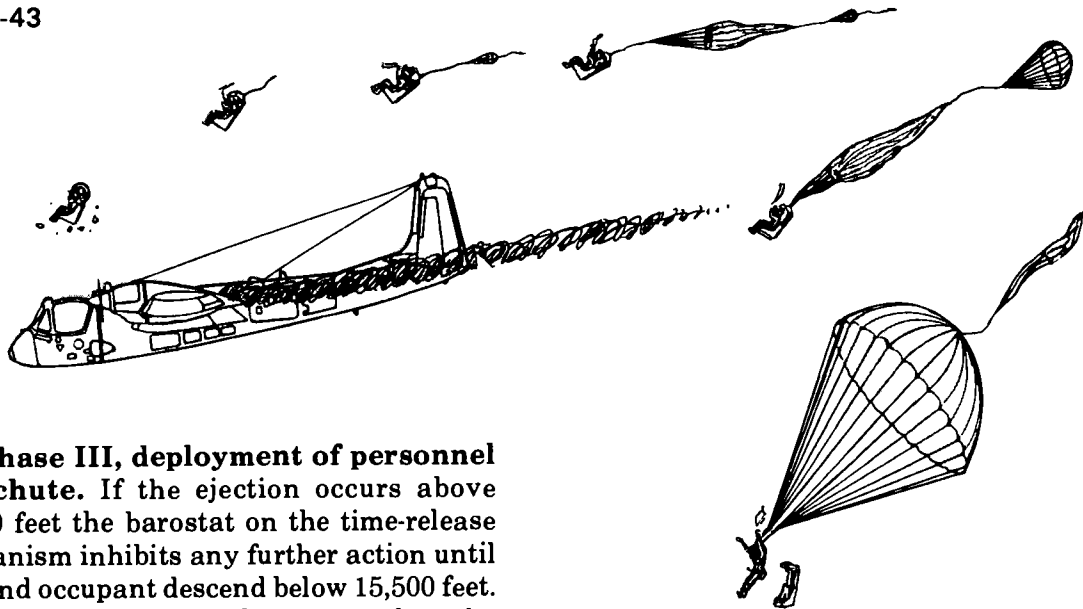

Phase III, deployment of personnel parachute. If the ejection occurs above 15,500 feet the barostat on the time-release mechanism inhibits any further action until seat and occupant descend below 15,500 feet. If the ejection occurs below 15,500 feet, the automatic series of events continues. The scissor holding the drogue shackle to the ejection seat opens, releasing the drogue parachute. The drogue parachute pull is

transmitted through the link line to the personnel parachute, extracting it from its pack for deployment.

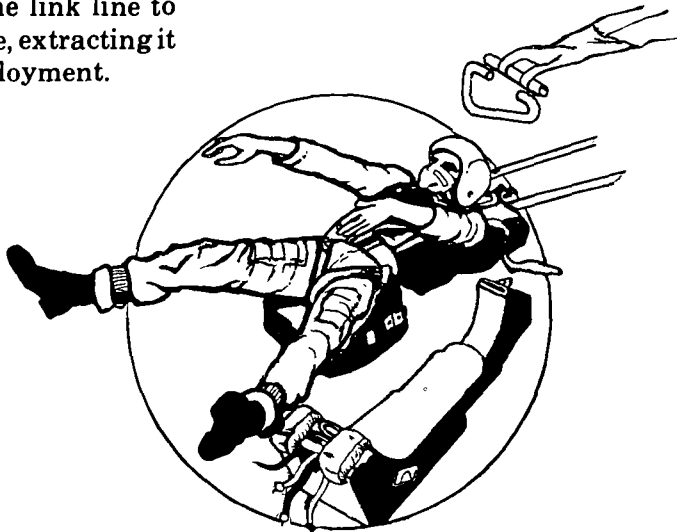

Phase IV, separation of seat and occupant. When the personnel parachute opens, the seat and occupant are separated. This separation action automatically disconnects the emergency oxygen hose from the occupant at the oxygen quick-disconnect fitting.

Parachute technique. Landing injury can be prevented by insuring that the quick-fit harness is adjusted tightly and by pulling the personnel parachute ripcord D-ring if an after-ejection emergency occurs.

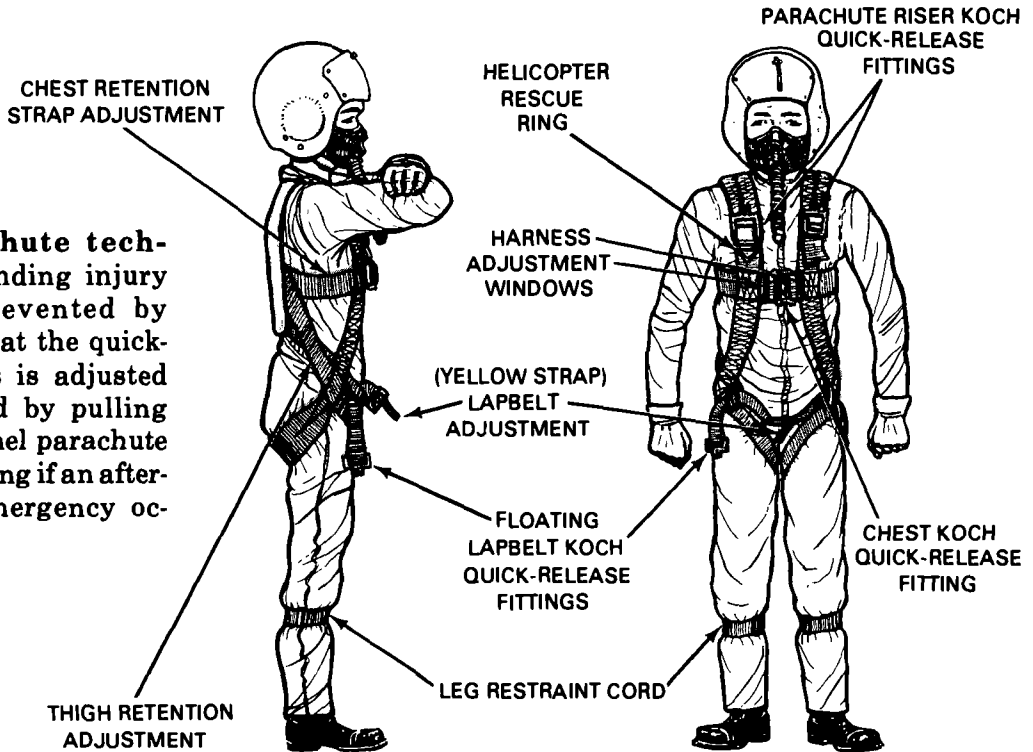

CHAPTER 5

FM 55-43

MANUAL AND EMERGENCY PROCEDURES

MANUAL OVERRIDE SYSTEM

The manual override system is to be used in the case of automatic system malfunctions, such as the following:

1. Ejection gun fails.
2. Ejection gun fires, but drogue gun fails.
3. Ejection and drogue guns fire, but time-release mechanism fails.
4. Ejection and drogue guns fire, time-release mechanism functions, but scissor fails to open.

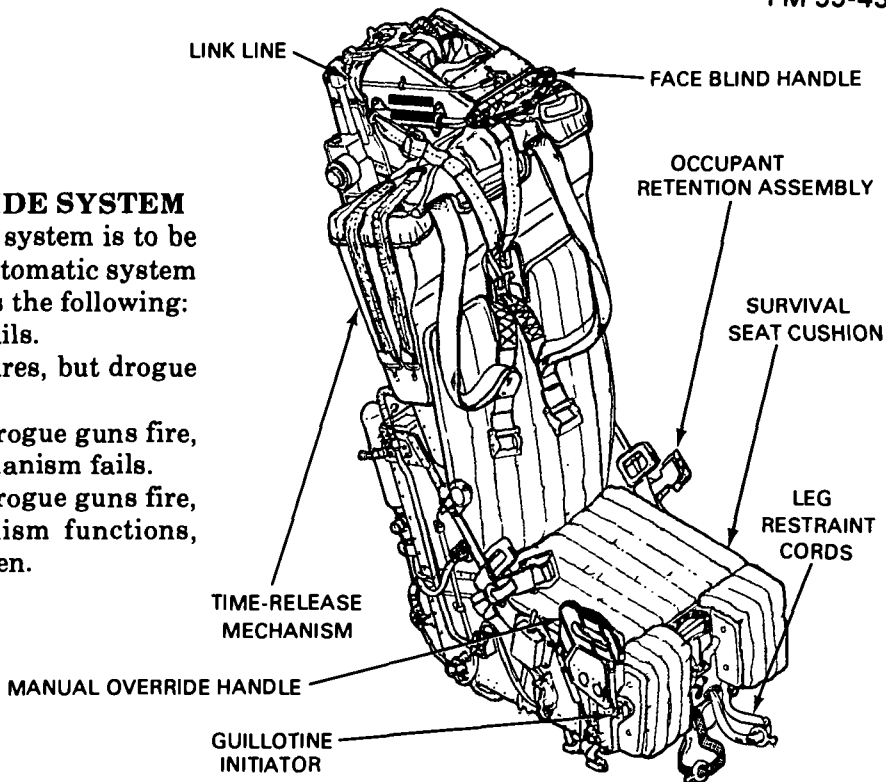

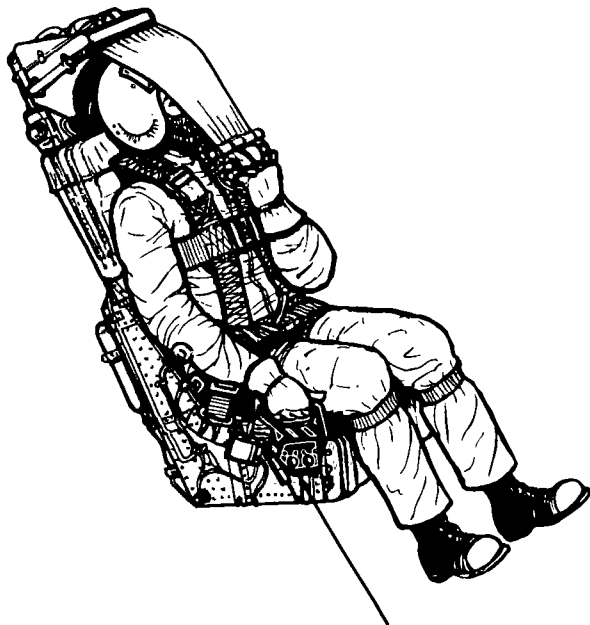

MANUAL OVERRIDE HANDLE

EMERGENCY PROCEDURE

If ejection is initiated at or below 14,000 feet mean sea level, and the personnel parachute does not deploy within 2 seconds after the seat leaves the aircraft, the manual deployment procedure must be used:

1. Grasp the manual override handle located on the right side of the seat bucket and lift the lever up and aft. This action releases the rigid seat survival kit assembly, shoulder harness loop strap, and leg restraint cords from the seat. The guillotine on the left side verticle beam cuts the drogue line and frees the personnel parachute from the drogue parachute.

2. Roll forward and push violently away from the seat. This action overcomes the spring tension of the sticker clips.

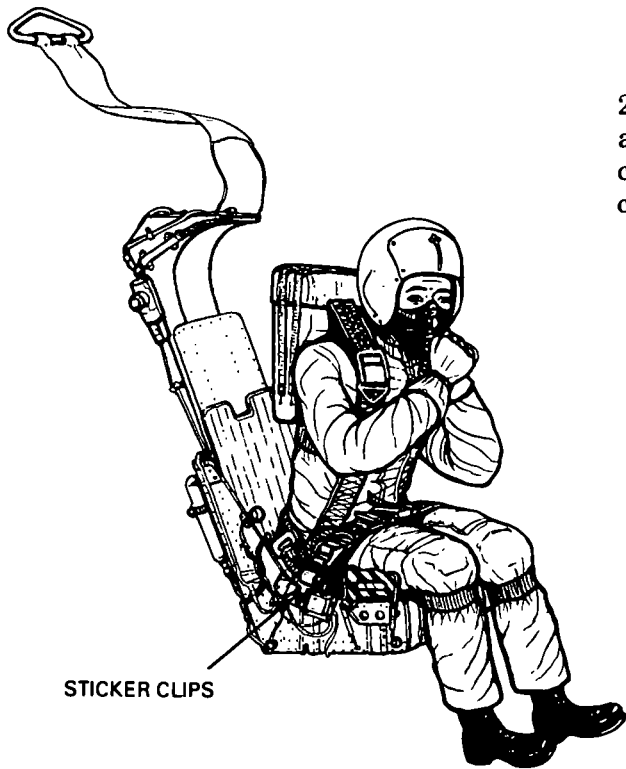

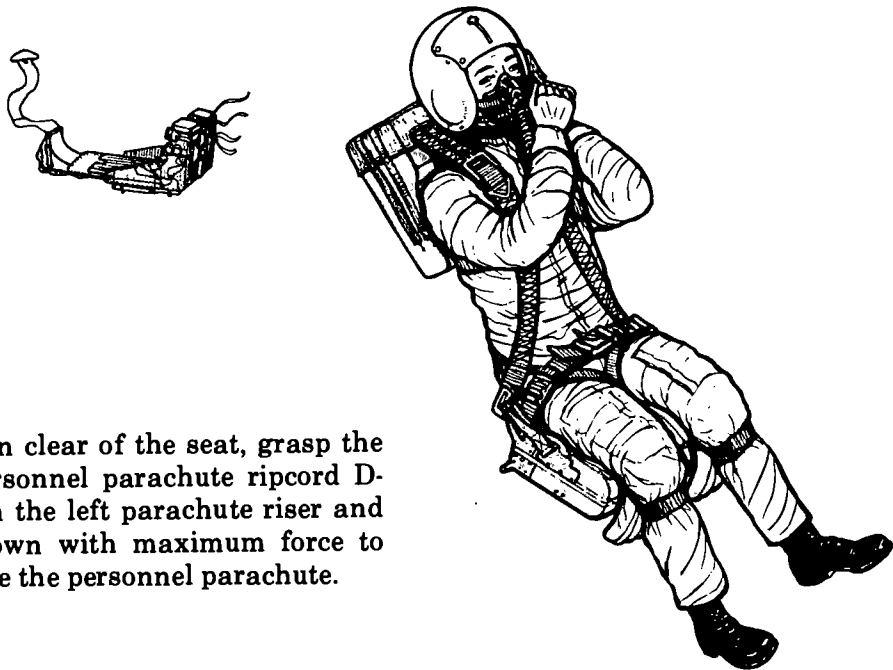

3. When clear of the seat, grasp the personnel parachute ripcord D-ring on the left parachute riser and pull down with maximum force to activate the personnel parachute.



DESCENT INTO WATER

Use the following procedure when descending into water:

1. Release rigid seat survival kit handle about 50 feet before touch-down. The life raft will automatically inflate on deployment.

2. Release parachute quick-disconnect fittings only after feet have touched the surface.

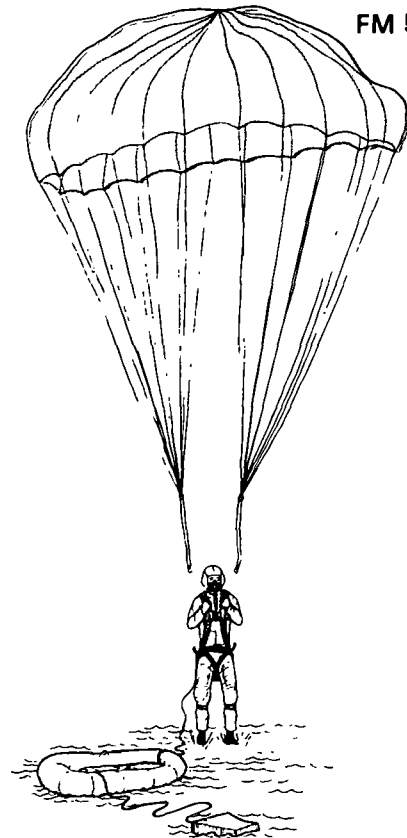

WARNING: Do not release parachute until feet touch water.

3. Inflate your personal life jacket before you enter the water. Enter the life raft head first from the small end.

INFLATE LIFE JACKET.

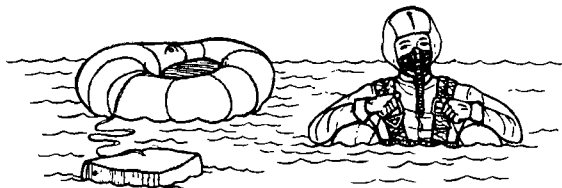

ENTER FROM SMALL END OF RAFT.

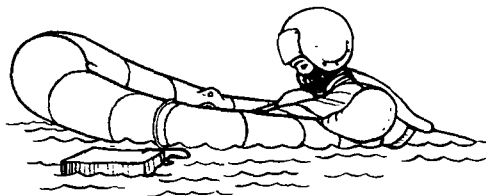

SECURE COMFORTABLE POSITION IN RAFT.

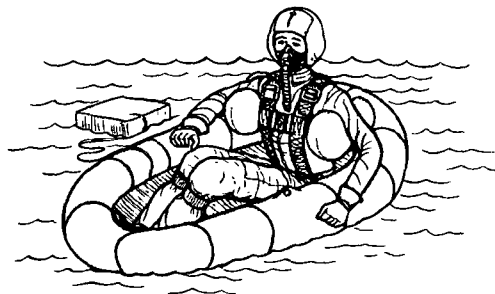

Crash landing-ditching procedure. Follow crash landing-ditching procedure in TM 55-1510-213-10 with emphasis on the following check-points:

Before impact

Lock shoulder harness and jettison escape hatch.

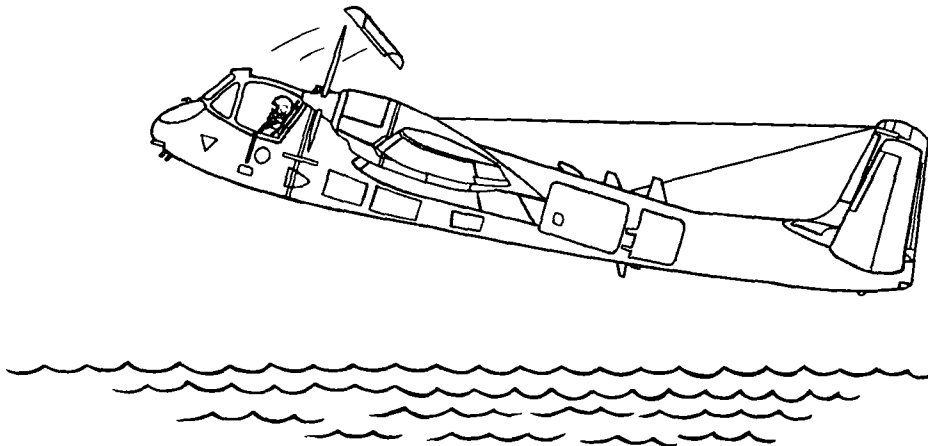

FM 55-43

After impact

Pull manual override. This releases the leg restraint cords, releases rigid seat survival kit retention lock from the seat, safeties the face blind and lower firing handles, and fires the guillotine, freeing the personnel parachute from the drogue parachute.

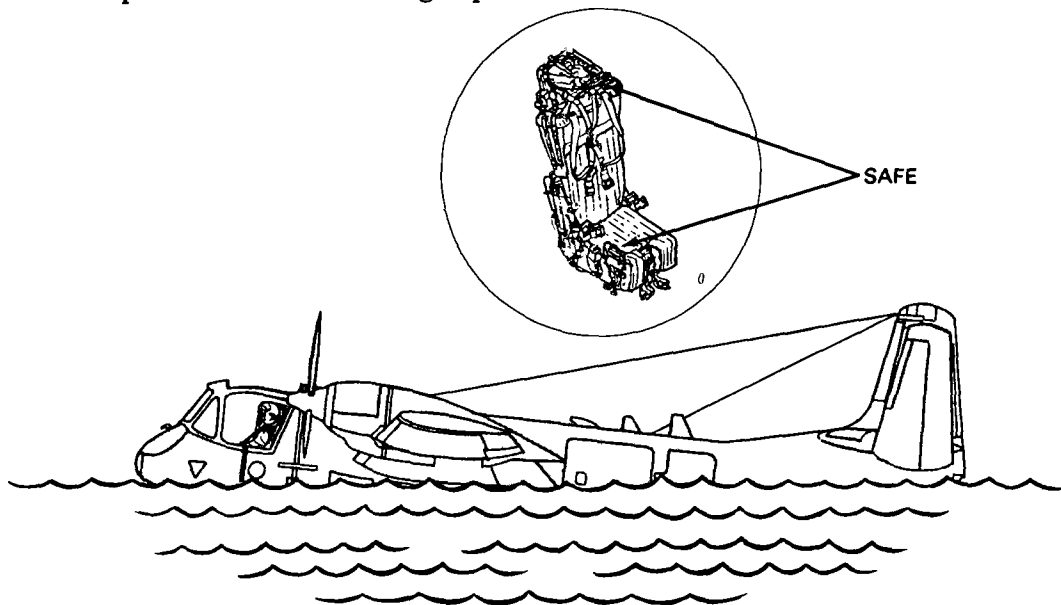

Exiting the aircraft. Use procedures outlined below when exiting the aircraft.

RELEASE PARACHUTE RISER QUICK-DISCONNECTS



STAND UP AND EXIT AIRCRAFT OVER WINDSHIELD

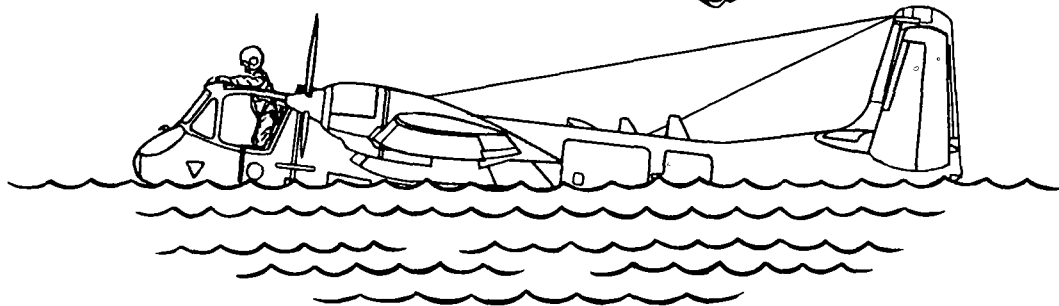

WARNING: Do not pull rigid seat survival kit release handle until clear of aircraft.

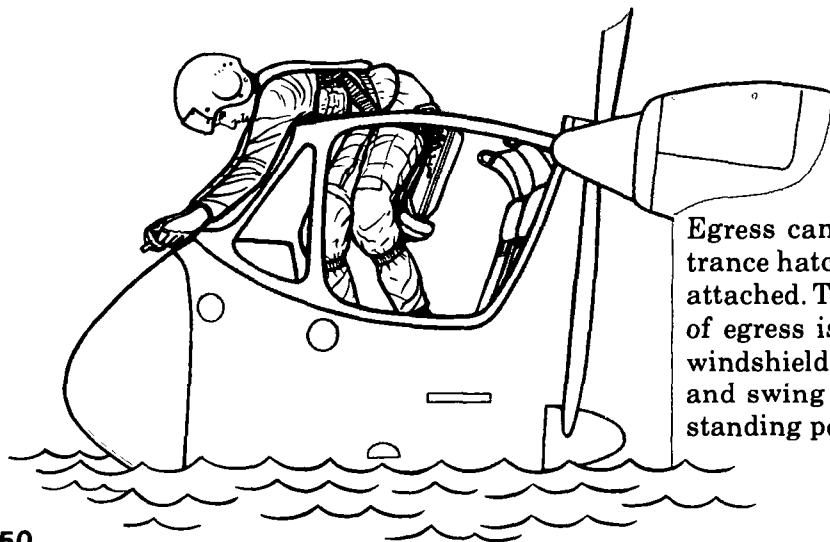

Egress cannot be done through entrance hatches with seat survival kit attached. The most expedient method of egress is with head down across windshield. Grasp pitot tube mount and swing feet downward to regain standing position.

INSPECTIONS**CHECKLISTS**

All required inspections on the MK-J5D ejection seat are contained in the applicable inspection checklists. This chapter only points out the checks with which a crew member or passenger should be familiar in order to monitor other individuals who are properly designated to perform them.

DAILY MAINTENANCE INSPECTION

The crew chief will use TM 55-1510-217PMD for daily inspections.

AVIATOR/CREW MEMBER PRE/POST FLIGHT INSPECTIONS

Use TM 55-213-10 or TM 55-1510-204-CL/2/3/4 when performing preflight/postflight inspections, with emphasis on checkpoints indicated below.

Before exterior check:

1. Ejection seats - safe. Check that face blind handle is locked (red tab up) and lower firing handle is locked (guard up).
2. Ground-lock safety pins - removed (seven pins).
3. Top latch mechanism - indicating dowel pin flush with plunger face, plunger flush with housing.
4. Personnel parachute D-ring - handle must be installed in spring clip.
5. Personnel parachute withdrawal line - withdrawal line, complete with Teflon cover, must pass through guillotine spring gate.
6. Guillotine cutter blade - blade must not contact withdrawal line cover.

7. Drogue gun cartridge installation (barrel) - lockwired and lead sealed.
8. Drogue gun mechanism trip rod - connected to ejection gun cross-beam fittings, and indicating collars flush or not more than one-half inch from outer barrel. Pins secured.
9. Tip-off compensating rocket dispenser cable - end fitting must be connected to drogue gun trip rod.
10. Personnel parachute restraint straps - properly routed and secured.
11. Personnel parachute risers - risers must not be twisted; roller yokes must not be separated.
12. Seat survival kit container - pull up on lapbelt harness vigorously to insure security; visually check sticker clips.
13. Leg restraint cords - secure, and check garters for condition.
14. Manual override handle - handle must be full down and connecting rod attached to guillotine sear.
15. Guillotine cartridge installation (breech) - lockwired and lead sealed.
16. Emergency oxygen bottle - disconnect lanyard connected to lapbelt half; check for pressure (1,800 psi).
17. Time-release mechanism trip rod - connected to ejection gun cross-beam fitting, and indicating collars flush or not more than one-half inch from outer barrel. Pip pin secure.
18. Time-release mechanism barostat - lockwired and lead sealed.

During exterior check (fuselage top):

Ejection seats (top) - check --

1. Firing cables - installed and attached to sear (thick on top, thin on bottom).
2. Scissor shackle - bolt head down.
3. Upper firing mechanism - lockwired and lead sealed.
4. Drogue withdrawal line - connected to drogue gun projectile and routed over all other lines at top of seat; withdrawal line connection pointed forward.
5. Drogue flap securing pin - safetied.
6. Drogue flap - check for deterioration.

Before takeoff:

Ejection seats - armed.

After landing:

Ejection seats - safe; face blind handle locked (red tab up) and lower firing handle locked (guard up).

Before leaving the aircraft:

Ground-lock safety pins - installed.

CHAPTER 7

EJECTION SEAT SIMULATOR

DESCRIPTION

The ejection seat simulator is a training device that simulates gravity forces encountered during ejection and provides ground training in emergency aircraft exit by means of the MK-J5D Martin-Baker ejection seat. The simulator manual is TM 55-6930-205-13&P.

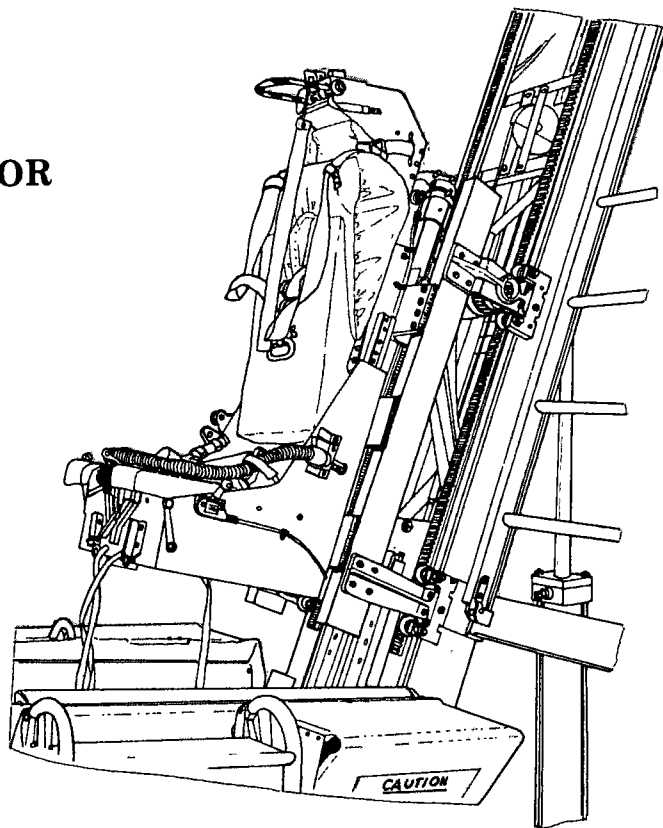

RECOMMENDED SIMULATOR CREW

The minimum crew recommended to safely and efficiently conduct ejection seat simulator firings includes one experienced NCO and one trained ejection seat instructor.

Appropriate checklists for operating the ejection seat simulator should be used at all times.

The following points are highlighted when the instructor demonstrates donning the prezized or adjustable harness and getting into the ejection seat.

1. The tight adjustment required for all restraining straps.
2. Operation of the quick-release fittings.
3. Fastening of the lapbelt buckle.
4. Operation of the inertia reel.
5. Operation of the seat adjustment switch.
6. Operation of the firing handle locks.

WARNING: Tight adjustment of the quick-fit harness is necessary to prevent separation of occupant from harness should jackknifing occur during ejection.

THE EJECTION DRILL

The trainee wears a protective helmet during ejection training. The following commands and responses are given:

Ready!

Student grasps the face blind firing handle with both hands with palms down, elbows in, knees close but not touching.

Fire!

Student pulls face blind firing handle sharply out and down. Head must be held back against the seat.

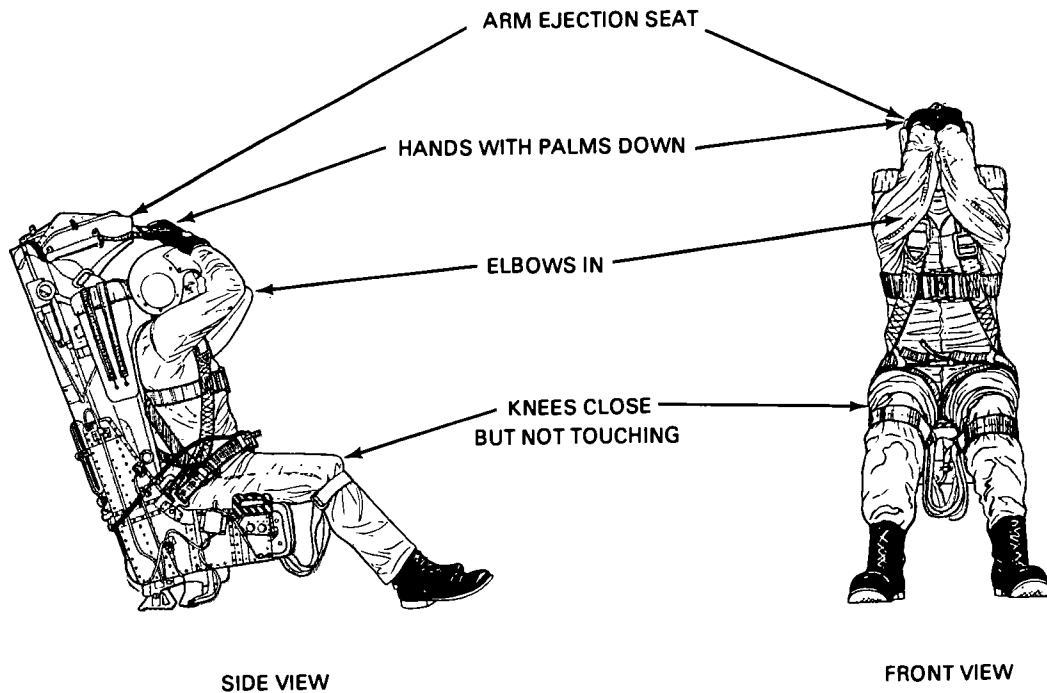

APPENDIX

REFERENCES

ARMY REGULATIONS

AR 95-1

Army Aviation; General Provisions and Flight Regulations

AR 310-50

Catalog of Abbreviations and Brevity Codes (microfiche only)

TECHNICAL MANUALS

TM 9-1300-206

Ammunition and Explosives Standards

TM 55-1510-204-CL/2/3/4

Operators' and Crewmembers' Manuals: Army Models OV-1A, OV-1B, and OV-1C, Airplane Observation STOL; Pilots' Checklist

TM 55-1510-213-10

Operator's Manual: OV-ID/RV-ID Aircraft

TM 55-1510-217 PMD

OV-1B, OV-1C, OV-1D, and RV-1D Aircraft; Preventive Maintenance Daily

TM 55-1680-308-24

Organizational, Direct Support, and General Support Maintenance Manual: Ejection Seats, Model MK-J5D (Martin-Baker)

FM 55-43

TM 55-6930-205-13&P	Operator's, Organizational and Direct Support Maintenance Manual including Repair Parts and Special Tools List; Ejection Seat, Training, Device 9E2A
TM 55-8465-212-10	Operator's Manual: Survival Kit, Cold Climate, Individual
TM 55-8465-213-10	Operator's Manual: Survival Kit, Hot Climate, Individual
TM 55-8465-214-10	Operator's Manual: Survival Kit, Overwater, Individual

DA PAMPHLETS

DA PAM 310-1	Consolidated Index of Army Publications and Blank Forms
---------------------	--

INDEX

Automatic Emergency Oxygen System	22	Ejection Seat Simulator	
Drogue Gun		Ejection Drill	57, 58
Firing Mechanism	17	Seat Height Adjustment	23
Inner and Intermediate Tubes ...	18 thru 20	Simulator Crew	55
Rigid Seat Survival Kit	21	Inspections	
Time-Release Mechanism	16	Daily Maintenance	51
Top Crossmember	13	Pre/Post Flight	51, 52, 53
Top Latch Mechanism	14	Manual and Emergency Procedures	
Ejections		After Impact	48
Automatic Operation	33	Before Impact	47
Command and Signal	31	Descent into Water	45
Deployment of Personnel Parachute ...	38	Emergency Procedures	42 thru 44
Face Blind Handle	32	Exiting the Aircraft	49
Lower Firing Handle	34	Manual Override System	41
Parachute Techniques	40	Mechanisms	
Separation of Seat and Occupant	39	Firing	17
Stabilization and Deceleration of		Time-Release	16
Seat and Occupant	37	Safety Precautions	
		Installing Ground Safety Pins ...	26 thru 28
		Prior to Servicing the Seat	29

FM 55-43

3 SEPTEMBER 1982

By Order of the Secretary of the Army:

E. C. MEYER
General, United States Army
Chief of Staff

Official:

ROBERT M. JOYCE
Major General, United States Army
The Adjutant General

DISTRIBUTION:

Active Army, USAR, and ARNG: To be distributed in accordance with DA Form 12-11A, Requirements for Army Aviation Organizational Aircraft Maintenance (Qty rqr block no. 2); plus: DA Form 12-31, Requirements for Section 1, Fixed Wing Aircraft (OV) (Qty rqr block no. 13 and 23).

Additional copies may be requisitioned from the US Army Adjutant General Publications Center, 2800 Eastern Boulevard, Baltimore, MD 21220.

3000021315

PENTAGON LIBRARY

DEFENSE INFORMATION AGENCY

MARTIN BAKER MK-J5D EJECTION SEAT
