

2M 54-6
copy 1

D/S Mar 72
2M 54-7

Reference

FM 54-6

Reference

DEPARTMENT OF THE ARMY FIELD MANUAL

THE AREA SUPPORT COMMAND

THE ARMY LIBRARY
WASHINGTON, D. C.



HEADQUARTERS, DEPARTMENT OF THE ARMY
MAY 1969

THE ARMY LIBRARY,
WASHINGTON, D. C.

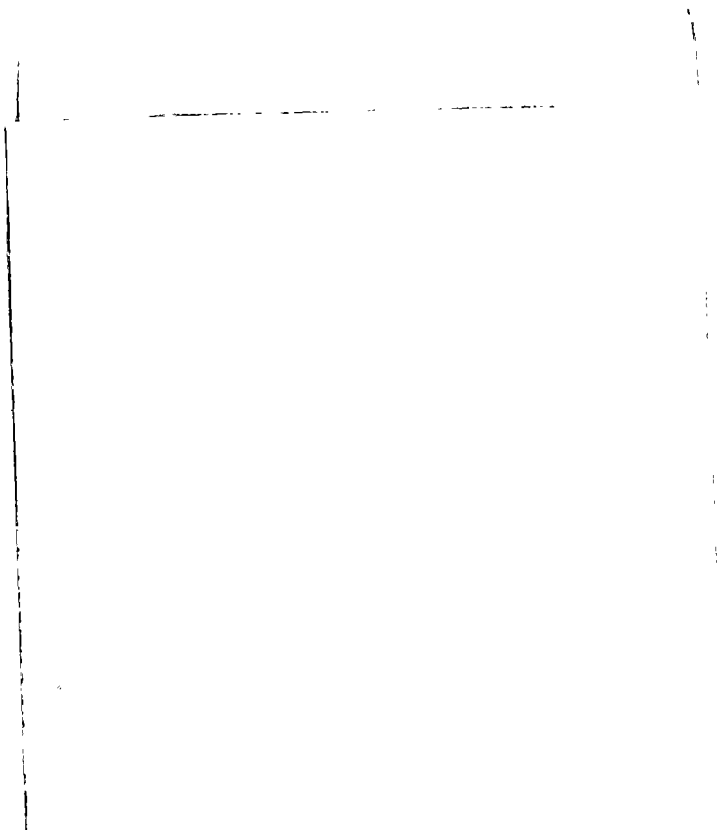

THE AREA SUPPORT COMMAND

	Paragraph	Page
CHAPTER 1. INTRODUCTION	1-1-1-7	1-1
2. AREA SUPPORT COMMAND HEAD- QUARTERS AND HEADQUARTERS SUPPORT UNITS		
Section I. Area support command headquarters	2-1, 2-2	2-1
II. Responsibilities and duties of ASCOM staff	2-3-2-14	2-2
III. Automatic data processing unit	2-15, 2-16	2-5
IV. Maintenance management detachment	2-17, 2-18	2-5
V. Personnel and administration battalion	2-19, 2-20	2-6
VI. Signal operations company (medium head- quarters)	2-21, 2-22	2-6
VII. Explosive ordnance disposal	2-23, 2-24	2-7
VIII. RAP	2-25, 2-26	2-8
CHAPTER 3. AREA SUPPORT GROUP		
Section I. General	3-1	3-1
II. ASGP headquarters	3-3, 3-4	3-1
III. Personnel services	3-5, 3-6	3-5
IV. Maintenance services	3-7-3-9	3-6
V. Transportation service	3-10-3-12	3-7
VI. Supply and services	3-13-3-15	3-8
VII. Installation support	3-16-3-18	3-9
VIII. Military police support	3-19, 3-20	3-10
IX. Finance direct support	3-21, 3-22	3-10
X. Other support services	3-23-3-25	3-11
CHAPTER 4. MILITARY INTELLIGENCE GROUP, COUNTERINTELLIGENCE		
Section I. General	4-1, 4-2	4-1
II. Military intelligence detachment, central records facility	4-3, 4-4	4-2
III. Military intelligence company, counterin- telligence	4-5, 4-6	4-3
CHAPTER 5. CIVIL AFFAIRS BRIGADE, AREA SUPPORT COMMAND	5-1-5-5	5-1
6. MILITARY POLICE SUPPORT	6-1-6-6	6-1
APPENDIX A. REFERENCES	A-1-A-4	A-1
B. TROOP LISTS, AREA SUPPORT COM- MAND	B-1-B-6	B-1
INDEX		Index-1

*This manual supersedes FM 54-6-1 (Test), 12 May 1967.



.

.



.

.



CHAPTER 1

INTRODUCTION

1-1. Purpose

This manual provides guidance on the organization and operation of an area support command (ASCOM) for personnel who need information relative to the combat service support provided to military forces in the communications zone (COMMZ). Related information may be found in the publications referenced in appendix A.

1-2. Scope

a. This manual describes the ASCOM headquarters and units subordinate to the ASCOM; responsibilities peculiar to the headquarters; and command relationships between the ASCOM headquarters, theater army support command (TASCOM), and other major subordinate headquarters of the TASCOM. The manual also describes the organizational elements of the ASCOM and the system or methods by which these elements provide combat service support in the COMMZ.

b. The contents of this manual are applicable to—

(1) General war, to include a consideration of the employment of and protection from nuclear, biological, chemical, and radiological (CBR) munitions; and operations in CBR environments.

(2) Limited war.

(3) Cold war, to include stability operations.

1-3. Recommended Changes

Users of this manual are encouraged to submit recommendations to improve its clarity or accuracy. Comments should be keyed to the specific page, paragraph, and line of the text in which the change is recommended. Reasons will be provided for each comment to insure

understanding and complete evaluation. Comments should be prepared using DA Form 2028 (Recommended Changes to Publications) and forwarded direct to the Commanding General, U.S. Army Combat Developments Command Institute of Combined Arms and Support, Fort Leavenworth, Kansas 66027. Originators of proposed changes that constitute a significant modification of approved Army doctrine may send an information copy, through command channels, to the Commanding General, U.S. Army Combat Developments Command, Fort Belvoir, Virginia 22060, to facilitate review and followup.

1-4. References

Users should employ this manual in conjunction with FM 54-7, FM 100-10, FM 101-5, field manuals of the 101-10 series, and other field manuals listed in appendix A, as appropriate.

1-5. Mission and Functions

a. Mission. ASCOM provides direct support (DS) service (less medical and ammunition) to the TASCOM, to units passing through or located in the COMMZ, and to other forces as directed by the TASCOM commander. The ASCOM is also responsible for planning, coordinating, and executing rear area protection (RAP) operation within the COMMZ.

b. Functions. ASCOM has responsibility for the following functions throughout its area as directed by TASCOM:

- (1) Personnel.
- (2) Legal.
- (3) Military intelligence support.
- (4) Civil affairs (CA) psychological operations (PSYOP).
- (5). Explosive ordnance disposal (EOD).

- (6) RAP.
 - (7) Decontamination.
 - (8) Military police.
 - (9) Local transportation.
 - (10) Receipt, storage, and issue of supplies and equipment (except medical and ammunition).
 - (11) Collection, classification, and salvage and disposal of supplies and equipment (less medical and ammunition).
 - (12) Field services.
 - (13) Installation support, to include real property maintenance activities (RPMA), construction planning, construction equipment maintenance and DS construction supply, and real estate services.
 - (14) Direct and limited general support (GS) maintenance services (except medical and ammunition).
 - (15) Labor service supervision.
 - (16) Comptroller services.
 - (17) CBR services and support as outlined in FM 3-1 (Test).
 - (18) Cryptologistics.
 - (19) Chemical and biological (CB) technical escort services.
- c. Automatic Data Processing.* The automatic data processing unit (ADPU) provides a large capacity automatic data processing center (ADPC) for the ASCOM and the engineer command (ENCOM). The ADPU also provides alternate automatic data processing equipment (ADPE) support for other TASCOM computer centers. ASCOM functions that may utilize ADP services include—
- (1) Unit readiness reporting.
 - (2) RAP.
 - (3) Personnel management.
 - (4) Maintenance management.
 - (5) Supply management.
 - (6) Labor management.
 - (7) Military police services.
 - (8) Budget, finance, and fiscal accounting services.
 - (9) Records administration.

d. Combat Service Support. The combat service support doctrine presented in this manual requires the availability of ADPE and associated communications systems to permit its

full application. Many of these items are under development; therefore, those tasks described in the manual to be performed by ADPE require a transition period during which current methods will be replaced as equipment becomes available.

1-6. Organization

(fig. 1-1)

a. The ASCOM consists of—

(1) A headquarters and headquarters company and special troops.

(2) Headquarters support activities:

(a) ADPC.

(b) Maintenance management center (MMC).

(c) Personnel service center.

(d) Signal operations company, medium headquarters (attached from the theater army signal group, U.S. Army Strategic Communications Command (USASTRATCOM) (theater)).

(3) Major subordinate organizations:

(a) Military police brigade.

(b) CA brigade (when assigned).

(c) Area support groups (ASGP).

(d) Military intelligence group, counterintelligence.

b. U.S. Army Security Agency (USASA) (theater) support of ASCOM operations is provided as arranged by theater army headquarters. These arrangements may include support of ASCOM communications, CA, security, stability, and/or RAP operations.

c. Special troops consists of units or elements attached for the support of the headquarters. Such attached units normally include, as an example, the signal operations company.

1-7. Command Relationships

The ASCOM is a major subordinate command of the TASCOM and is coequal with the other TASCOM commands.

a. With Higher Headquarters. TASCOM headquarters provides the ASCOM policy direction, broad guidance, and general supervision on area support and RAP planning for the entire COMMZ.

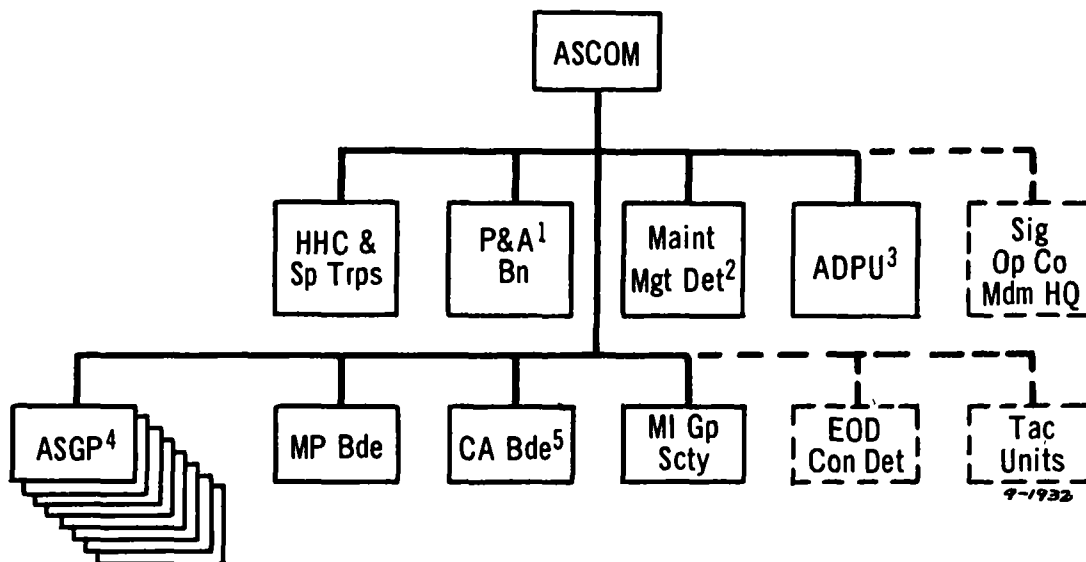

LEGEND

 Attached as required.

- ¹Provides personnel to operate the personnel service center.
- ²Provides personnel to operate the maintenance management center (MMC).
- ³Provides equipment and personnel to operate the ADPC.
- ⁴As required (up to 8 groups).
- ⁵When assigned.

Figure 1-1. Area support command.

o. With Other TASCOM Organizations. The ASCOM exercises area control within the COMMZ as designated by the TASCOM. ASGP of the ASCOM have a host-tenant relationship with units of other commands within the group area. The ASGP provides direct combat service support services (less medical and ammunition) to tenant units and is responsible for RAP planning and execution. Informal liaison is maintained directly with the coordinat-

ing staffs of other TASCOM subordinate commands on technical matters.

c. With Field Army. The ASCOM maintains coordination with field army support command (FASCOM) on backup CA support to field army as directed when ASCOM has CA responsibility. ASCOM, on direction of TASCOM, will provide marshaling support to theater army or field army airborne forces.



CHAPTER 2

AREA SUPPORT COMMAND HEADQUARTERS AND HEADQUARTERS SUPPORT UNITS

Section I. AREA SUPPORT COMMAND HEADQUARTERS

2-1. Mission and Functions

a. Mission. Area support command (ASCOM) headquarters—

(1) Commands, controls, and supervises all assigned and attached units.

(2) Provides direct support (DS) services (less medical and ammunition) on an area basis, through subordinate operating groups, to military forces in the communications zone (COMMZ) as directed by theater army support command (TASCOM).

(3) Plans, coordinates, and supervises intelligence, physical security, and rear area protection (RAP) (rear area security and area damage control) activities within the COMMZ.

b. Functions. ASCOM headquarters—

(1) Develops and provides policies and planning guidance in its areas of responsibility.

(2) Develops and provides priorities and allocations for DS services in accordance with policies and directives of higher headquarters.

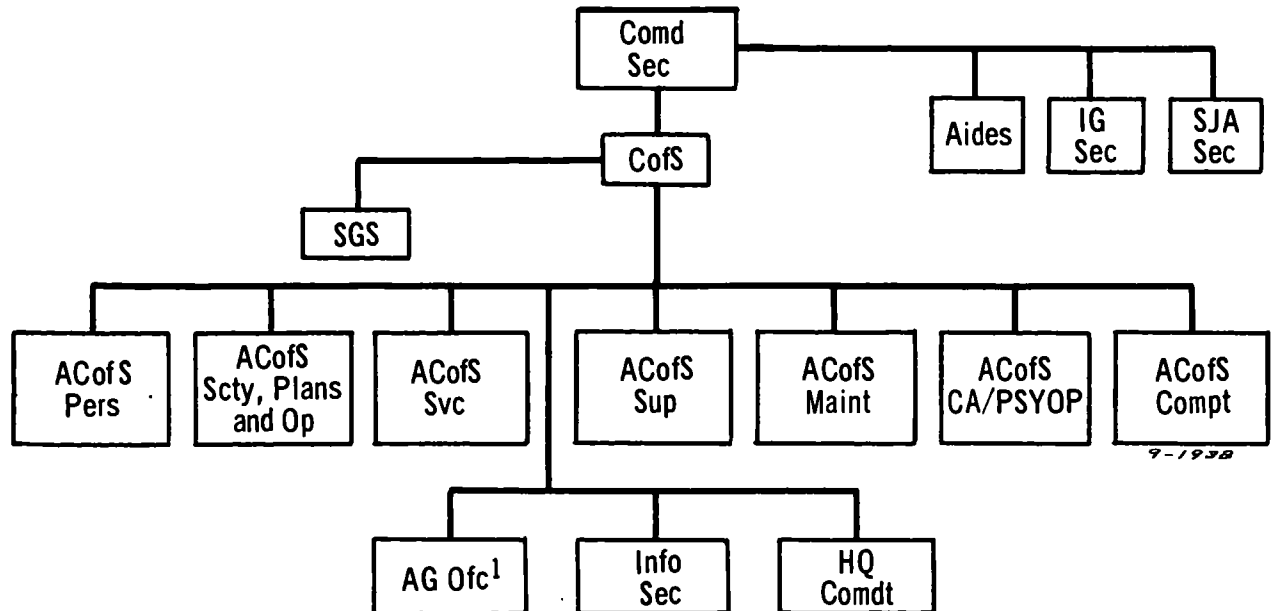

¹Provides internal administrative support to the HQ under the staff supervision of the ACofS, pers.

Figure 2-1. Area support command headquarters.

(3) Coordinates and exercises management control over combat service support activities of subordinate units.

(4) Advises the TASCOM commander, his staff, and other commands on matters falling within the ASCOM areas of responsibility.

(5) Serves as a supporting unit for ele-

ments over which higher headquarters retains operational control.

2-2. Organization

ASCOM headquarters (fig. 2-1) is organized along general staff lines with most special staff elements integrated into appropriate general staff sections.

Section II. RESPONSIBILITIES AND DUTIES OF ASCOM STAFF

Note. Responsibilities and duties of staff officers as described in FM 101-5 apply to the ASCOM staff.

2-3. Chief of Staff

The chief of staff (CofS) directs and supervises the activities of the staff elements. He establishes priorities for the use of automatic data processing (ADP) facilities.

2-4. Assistant Chief of Staff, Personnel

The assistant chief of staff (ACofS), personnel—

a. Processes personnel and administrative actions that by regulation or policy require action by the ASCOM commander.

b. Supervises the personnel services center.

c. Supervises the staff chaplain functions.

2-5. ACofS, Security, Plans and Operations

The ACofS, security, plans, and operations—

a. Prepares broad planning guidance, policies, and programs pertaining to command organizations, operations, communications, and functions.

b. Supervises and controls the operations of the military intelligence group, counterintelligence.

c. Provides staff supervision and centralized control of explosive ordnance disposal (EOD) services in the COMMZ.

d. Develops policies, reviews plans, and exercises staff supervision over RAP operations throughout the COMMZ.

e. Provides the commander estimates of damage resulting from nuclear attack and estimates of contamination resulting from chemical or biological (CB) attack. In postattack recovery operations, he recommends priorities

and coordinates reconstruction operations with supporting construction forces through the ACofS, services.

f. Maintains close coordination with the cryptologistics activities located in the area support groups (ASGP), and exercises staff supervision over all communications security (COMSEC) activities/operations.

g. Prepares, authenticates, and publishes operation plans and orders for the command, using input from other staff sections.

2-6. ACofS, Services

The ACofS, services—

a. Develops policies and plans. He coordinates construction, transportation, and field services.

b. Develops and coordinates requirements for real estate and field installations for the command and prepares plans for their acquisition, allocation, and use. He furnishes real estate and services needed for tactical unit marshaling areas, as directed.

c. Supervises installation support operations including real estate, fire protection, utilities operation, and the repair of real property.

d. Coordinates traffic control activities with other staff sections and with the transportation command (TRANSCOM).

e. Supervises communications operations.

2-7. ACofS, Supply

The ACofS, supply—

a. Develops policies, plans, and programs and coordinates and supervises supply activities, including salvage and property disposal.

b. Recommends action on requisitions for re-

gulated items submitted by subordinate commands.

c. Prescribes, as authorized by TASCOM headquarters, distribution of supply levels among the ASGP.

d. Has staff responsibility for the supply of construction materials, equipment, and parts for that equipment necessary to perform the installation support mission. This office normally is not concerned with project stocks of construction materials other than to monitor throughput from depot to user since the volume of these requirements normally precludes retail treatment.

2-8. ACofS, Maintenance

The ACofS, maintenance—

a. Serves as principal staff adviser and coordinator on all matters pertaining to the maintenance support mission. He also serves as the command materiel readiness officer.

b. Maintains liaison with TASCOM headquarters on matters relating to long-range resource requirements (e.g., personnel, materiel, and maintenance troop units) and with the supply and maintenance command (SMCOM) headquarters on matters relating to evacuation of workload overflow, scrap, and items requiring higher category maintenance.

c. Exercises general staff supervision and normally has operational control of the ASCOM maintenance management center (MMC) and provides policies, data and report requirements, and general guidance on which maintenance data collection and processing are based. He analyzes reports generated as a result of data processing and takes or recommends necessary remedial action. The ACofS, maintenance, insures that subordinate ASGP receive feedback information generated as a result of data collection, processing, and analysis.

d. Recommends the allocation and deployment of units and the allocation of materiel and personnel to accomplish the ASCOM maintenance support mission. This function includes recommendation for use of auxiliary

labor and local procurement of facilities, supplies, and services, as necessary.

e. Coordinates and controls, as necessary, the workload of subordinate ASGP maintenance units and items requiring further evacuation.

f. Develops the maintenance inspection plan and programs inspections of subordinate units. He provides policy and procedural guidance to the command maintenance management inspection teams organized from maintenance personnel resources for this purpose.

g. Determines the requirement for recurring or special reports to satisfy the informational and management needs of ASCOM or TASCOM headquarters. ASCOM MMC provides data and reports that are required from ASCOM by the MMC of the SMCOM for overall maintenance management within the theater. The ACofS, maintenance collects and evaluates these reports and takes action on the basis of their information.

h. Establishes and publishes for the command, policies and procedures for maintenance support operations based on policies and directives of the TASCOM and ASCOM commanders. These policies and procedures include such information as maintenance standards and inspection standards (when not published in other regulatory media); deviations from such standards, when necessary; type and frequency of reports required; priorities for repair of materiel; criteria for control of operational readiness floats; modification work order implementation procedures; and limitations on the time to be expended in the maintenance of specific types of items by the various maintenance categories.

i. Coordinates and supervises the collection, evacuation, classification, or destruction of U.S. and foreign materiel, as required.

j. Provides requirements to the TASCOM and SMCOM for secondary reference and secondary transfer calibration support and effects necessary coordination with the activity/unit responsible for providing this support.

k. Coordinates with the SMCOM on requirements for the evacuation of unserviceable materiel.

l. Provides information to the ACofS, supply, on repair parts problem areas and coordinates them with him.

2-9. ACofS, Civil Affairs/Psychological Operations

The ACofS, civil affairs/psychological operations (CA/PSYOP)—

- a. Is the principal staff assistant on matters pertaining to the civil population, its government, economy, and institutions.
- b. Prepares CA policies, plans, orders, and directives.
- c. Coordinates CA activities with other staff sections.
- d. Supervises CA operations in the COMMZ.
- e. Develops plans and policies for PSYOP.
- f. Exercises staff supervision over PSYOP.
- g. Recommends allocation of PSYOP units.

2-10. ACofS, Comptroller

The ACofS, comptroller—

- a. Analyzes ASCOM funding programs and budget guidance and recommends courses of action. He coordinates and develops a command position on budgetary matters and prepares budgetary reports. The ACofS, comptroller, performs periodic analysis of fund utilization. He provides guidance to the command on financial matters.
- b. Conducts internal reviews of ASCOM headquarters and subordinate elements. He also conducts internal reviews of other COMMZ elements as required.
- c. Provides general staff supervision over ADP activity. He schedules, monitors, reviews, and evaluates ADP systems and recommends to the CofS appropriate changes.

2-11. Inspector General

The inspector general (IG) inquires into matters pertaining to the performance of the mission, state of discipline, efficiency, and economy by conducting inspections, investigations, surveys, and studies as directed by the commander and as prescribed by law and Army regulations. He reports thereon. The IG—

- a. Advises staff sections concerning matters noted during inspections and furnishes these

section with copies of extracts of inspection reports of direct interest to the staff section.

b. Receives, investigates, and reports on allegations, complaints, and grievances of individuals and agencies.

c. Recommends action to correct deficiencies and delinquencies noted in inspections or investigations.

2-12. Staff Judge Advocate

a. The staff judge advocate (SJA) is the legal adviser to the commander. He is responsible for—

- (1) Administering claims matters, including the adjudication and certification for payment of claims in appropriate cases.

- (2) Providing legal opinions on international law problems (e.g., Hague regulations, the Geneva Conventions of 1949, status-of-forces agreements).

- (3) Examining procurement contracts and furnishing advice in connection therewith.

- (4) Administering war crimes matters within the command.

- (5) Furnishing legal assistance to military and other authorized personnel of the command concerning personal legal problems of a civil nature.

- (6) Exercising technical supervision of judge advocate general service operations (JAGSO) teams, when attached.

b. The ASCOM commander, the ASGP commander, and the military police brigade commander normally are authorized to convene general courts-martial. Commanders of groups and battalions are authorized to convene special and summary courts-martial. The SJA supervises the administration of military justice in the command.

2-13. Adjutant General's Office

This office operates under the general staff supervision of the ACofS, personnel. It provides internal administrative services for the ASCOM headquarters to include a distribution center, reproduction facilities, central classified document control and repository, forms management, and library service for headquarters correspondence and publications. It coordinates

with the servicing Army Post Offices for receipt and dispatch of official mail.

2-14. The Information Officer

The information officer's functions and duties are described in FM 101-5.

Section III. AUTOMATIC DATA PROCESSING UNIT

2-15. General

This unit provides a large capacity automatic data processing center (ADPC) for the ASCOM and the engineer command (ENCOM). It also provides alternate automatic data processing equipment (ADPE) support for other TASCOM computer centers. It can—

a. Install, operate, and maintain general purpose data processors, including associated devices and data transmission terminals.

b. Maintain a computer program library and adapt it to local requirements for data processing.

2-16 Assignment

The automatic data processing unit (ADPU) (fig. 2-2) is assigned to ASCOM headquarters on the basis of one per ASCOM. The ADPU is not involved in the management of the combat service support functions. It simply provides machine services. It uses computer programs developed centrally in the continental United

States (CONUS) based on centrally developed functional systems. Programmers and ADP analysts in the ADPC are permitted to make only minor modifications to these systems. There is a limited capability for design and programming.

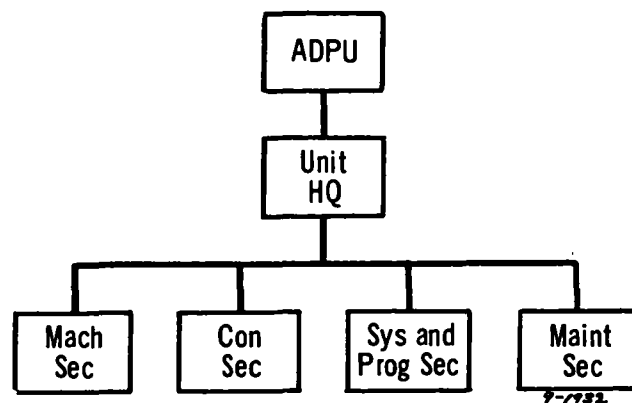

Figure 2-2. Automatic data processing unit.

Section IV. MAINTENANCE MANAGEMENT DETACHMENT

2-17. General

The maintenance management detachment operates the MMC, a functional control center, for the ASCOM. It performs routine maintenance management functions for the ACofS, maintenance, ASCOM headquarters. The MMC collects, sorts, and analyzes maintenance data, reports, and listings that subordinate units of the command and the supporting ADPC provide, to include data emanating from supported units or commands. The MMC influences the performance of maintenance and maintenance-related operations of subordinate units of the command through review and analyses of maintenance data and reports as a basis for recommendations to the ACofS, maintenance.

The MMC also prepares instructions for subordinate units on the types and frequency of reports required for routine maintenance management and provides functional guidance to the supporting ADPC on the processing of data submitted by subordinate units of the command. In addition, it provides the ACofS, maintenance, higher headquarters, and other commands with summary management data, such as printouts, graphical data, and reports.

2-18. Operations

The ASCOM MMC exercises routine management over certain activities of subordinate maintenance units. FM 29-20 provides complete details on the functions and method of operations of the MMC.

Section V. PERSONNEL AND ADMINISTRATION BATTALION

2-19. General

DS personnel and administrative support activities are centralized within the ASCOM. A personnel service center is formed to provide this support to all nondivisional troops in the COMMZ. The personnel and administration (P&A) battalion operates the personnel service center under the staff supervision of the ACofS, personnel, ASCOM. The personnel service center is supported by the servicing ADPU. Requests for action are acted on by the P&A battalion within the policy of the respective headquarters supported. FM 12-2 provides a detailed discussion of command relationships, operational concepts, and organization and capabilities.

2-20. Organization

The P&A battalion is assigned to the ASCOM. Figure 2-3 shows the organization of this battalion.

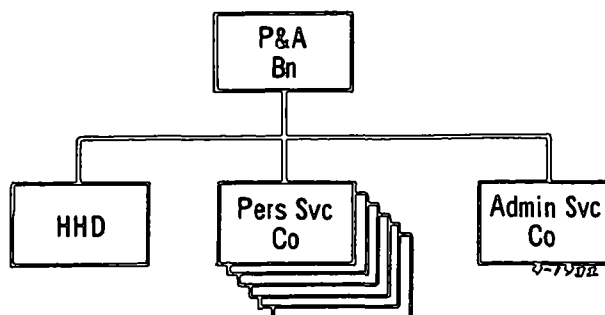

Figure 2-3. Personnel and administration battalion, ASCOM.

Section VI. SIGNAL OPERATIONS COMPANY, MEDIUM HEADQUARTERS

2-21. General

The signal operations company, medium headquarters (TOE 11-127) (fig. 2-4), provides internal signal communications facilities and photographic service. It depends on signal units of the area communications system for trunking circuits and carrier termination facilities for integration into the area communications system. This company—

a. Installs, operates, and maintains, on a 24-hour basis, communications facilities for ASCOM headquarters to include—

- (1) Manual telephone central office and local telephone system.
- (2) Circuit control and information services.
- (3) Secure tape relay and teletypewriter circuits.
- (4) Secure radio teletypewriter circuits.

b. Establishes and operates a message center that provides—

- (1) Message handling facilities.
- (2) Facsimile and data transceiver facilities.
- (3) Motor messenger service within the supported headquarters complex and to its subordinate headquarters and to message relay

stations operated by the signal messenger companies.

c. Performs photographic service on a 24-hour basis to include—

- (1) Still and motion picture coverage (except airphotography).
- (2) Operation of photographic laboratory for processing ground and airphotographic coverage (except air combat surveillance), as required.

d. Performs organizational and DS maintenance of organic signal equipment.

e. Provides unit administration, supply and mess facilities, and organizational maintenance of organic arms, vehicles, and power equipment.

f. Depends on TOE 11-500 teams for additional communication capabilities.

2-22. Assignment

The signal operations company, medium headquarters, is assigned to the theater army signal group, U.S. Army Strategic Communications Command (USASTRATCOM) (theater), and is under its operational control. It is attached to the ASCOM headquarters for administrative support.

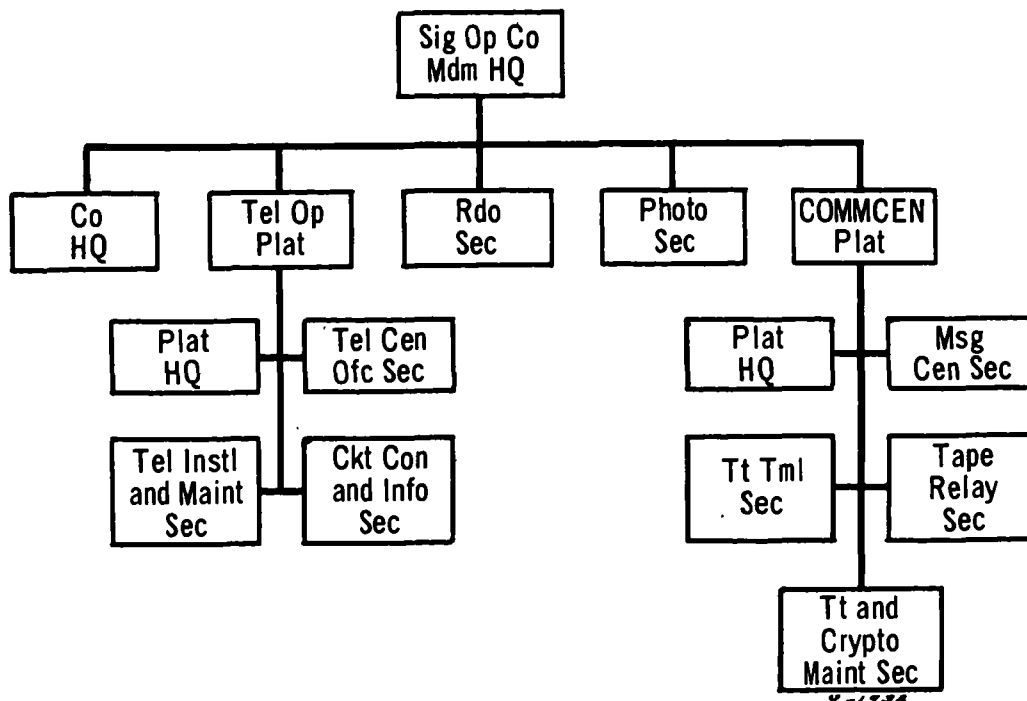

Figure 2-4. Signal operations company, medium headquarters.

Section VII. EXPLOSIVE ORDNANCE DISPOSAL

2-23. General

EOD support activities are controlled and supervised at the ASCOM headquarters by the ACofS, security, plans, and operations. The EOD branch of the ACofS, security, plans, and operations section, executes the EOD support plan through the EOD control detachment and the required number of EOD detachments. EOD detachments are authorized on the basis of one per ASGP.

2-24. Operational Concepts

a. The EOD branch—

- (1) Provides staff supervision of EOD service in the COMMZ.
- (2) Prepares directives governing COMMZ EOD service.
- (3) Provides guidance to subordinate units relative to EOD service.
- (4) Monitors, coordinates, and controls

EOD support activities and the conduct of the explosive ordnance reconnaissance program.

(5) Advises the ACofS, security, plans, and operations, on apportionment of personnel, units, special equipment, and the assignment of EOD incident priorities, as required.

b. Requirements for EOD service are reported to the rear area operations center (RAOC) at ASGP'S. RAOC reports the requirement to the control detachment attached to ASCOM. The control detachment assigns the requirement to the disposal detachment designated to provide EOD service in that geographical area or to the nearest available unit. Within the limits of established policy, EOD requirements may be reported directly to disposal detachments.

c. FM 31-45 contains details of the mission, responsibilities, functions, and method of operation for COMMZ EOD units.

Section VIII. RAP

2-25. General

RAP includes those actions taken before, during, or after attacks to avoid or reduce the effects of enemy actions, major accidents, or natural disasters. RAP includes rear area security and area damage control measures and associated political considerations.

a. Rear area security measures include all actions to prevent, neutralize, or destroy enemy attacks on units, activities, and installations in rear areas. These measures do not include active air defense operations or actions against enemy threats large enough to endanger the command. Attacks so great as to endanger the command as a whole are part of the main battle requiring use of reserves or combat units from forward areas and are beyond the scope of rear area security.

b. Area damage control includes those measures taken before, during, and after attack by nuclear or other weapons, or by natural disaster, to avoid and reduce their effects and to aid in the continuation or reestablishment of combat service support.

2-26. Command Relationships

The ASCOM commander is responsible for planning, coordinating, and executing RAP in the COMMZ. Normally, he further delegates responsibility for coordination and execution of RAP within an ASGP area to the ASGP commander. The ASGP commander accomplishes these functions through the assigned RAOC. Organization and functions of a RAOC are explained in detail in chapter 3 and in FM 19-45.

CHAPTER 3

AREA SUPPORT GROUP

Section I. GENERAL

3-1. Introduction

a. Mission and Functions. Area support groups (ASGP) are assigned areas of responsibility dependent on densities of military units and materiel to be supported, as well as political boundaries and identifiable terrain features. Normal assignment of the ASGP is to area support command (ASCOM) on the basis of one per 15,000 to 30,000 troops to be supported in the communications zone (COMMZ). ASGP provide direct combat service support (less medical and ammunition) to units located in or passing through the COMMZ. They depend on other organizations for transport, security, personnel administration, and communication support. The ASGP are organized for specific missions that theater army support command (TASCOM) headquarters assigns through ASCOM headquarters. They will assist those supported installations of the other TASCOM commands in matters within the purview of the ASGP's responsibility. Functions to be performed include—

- (1) Personnel services (less centralized personnel and administrative services).
- (2) Legal services.
- (3) Maintenance services (except ammunition and medical).
- (4) Transportation services.
- (5) Supply and services (except ammunition and medical supply).
- (6) Installation support.
- (7) Military police support.

- (8) Military intelligence support.
- (9) Explosive ordnance disposal (EOD).
- (10) Rear area protection (RAP).
- (11) Collection, classification, and salvage of supplies and equipment.
- (12) Comptroller services.

b. Organization. Figure 3-1 depicts the organization of the ASGP, ASCOM.

c. Command Relationships.

(1) *With ASCOM.* The ASGP is a major subordinate command of the ASCOM.

(2) *With units of other commands located within the group area.* A host-tenant relationship exists between the ASGP and supported units in the area.

3-2. Concept of Operation

a. The operating units of the ASGP provide direct combat service support (less medical and ammunition) for the TASCOM commands and other designated forces in the COMMZ. Elements of the ASGP's deploy near forces and materiel supported where practicable; however, requirements for dispersion and security are observed.

b. The ASGP provide direct support (DS) services (less medical support, ammunition, and centralized personnel and administrative services) to approximately 15,000 personnel. This capability can be expanded to support up to 30,000 personnel by adding units or employing nonmilitary labor.

Section II. ASGP HEADQUARTERS

3-3. General

a. Mission. ASGP headquarters provides command and control of assigned and attached

combat service support units forming a composite, multifunctional organization.

b. Functions.

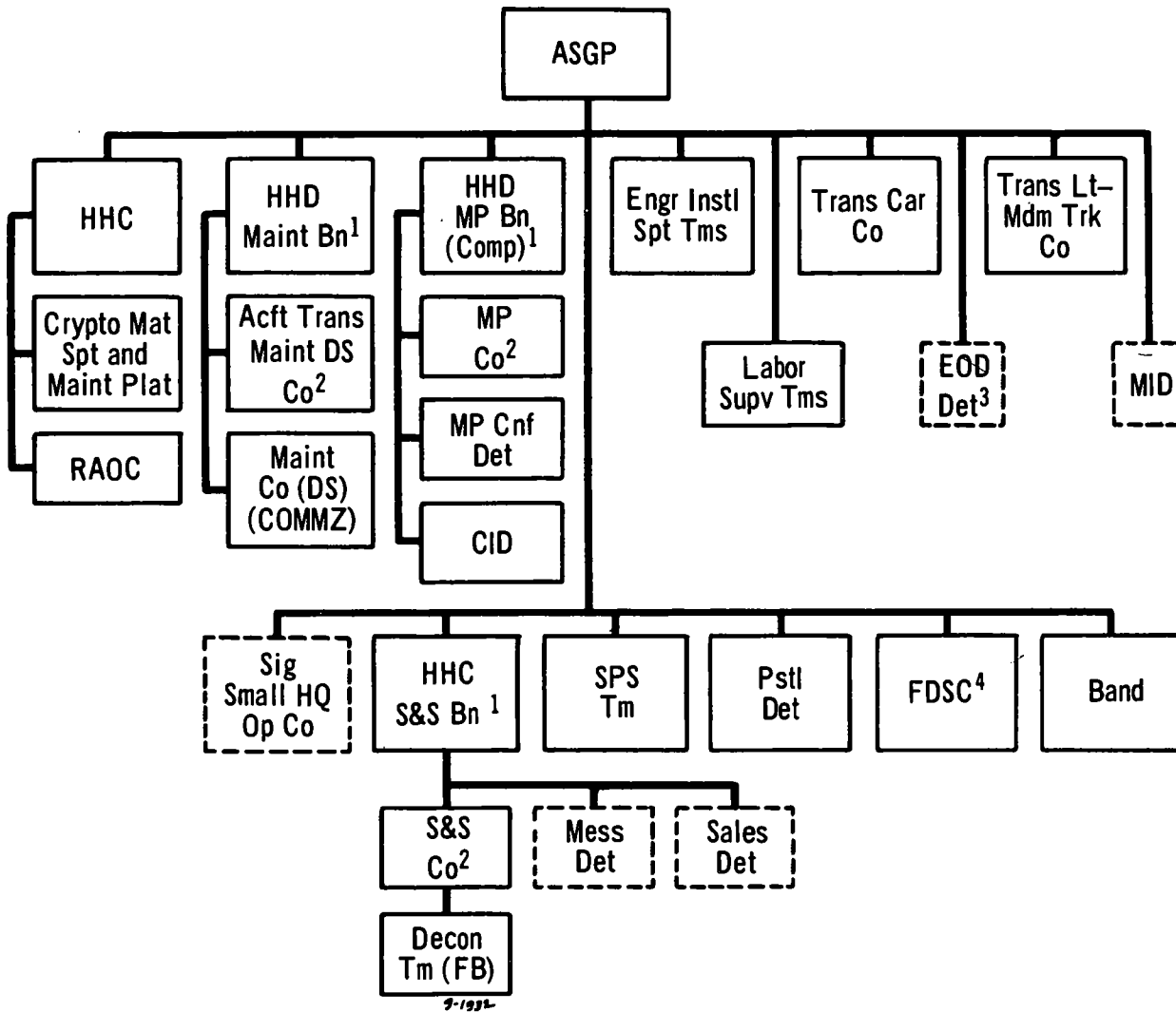

LEGEND

 Attached units.

- ¹Assigned as required when 3 or more subordinate elements are employed.
- ²Assigned as required.
- ³Attached as required.
- ⁴Finance direct support company.

Figure 3-1. Area support group, ASCOM.

(1) ASGP headquarters provides the organizational structure, personnel, and equipment required for command, control, staff planning, and supervision of assigned or attached units.

(2) The functional areas that the directors of personnel and administration (P&A); security, plans, and operations; installations; services; supply; and maintenance supervise generally parallel those in the general staff

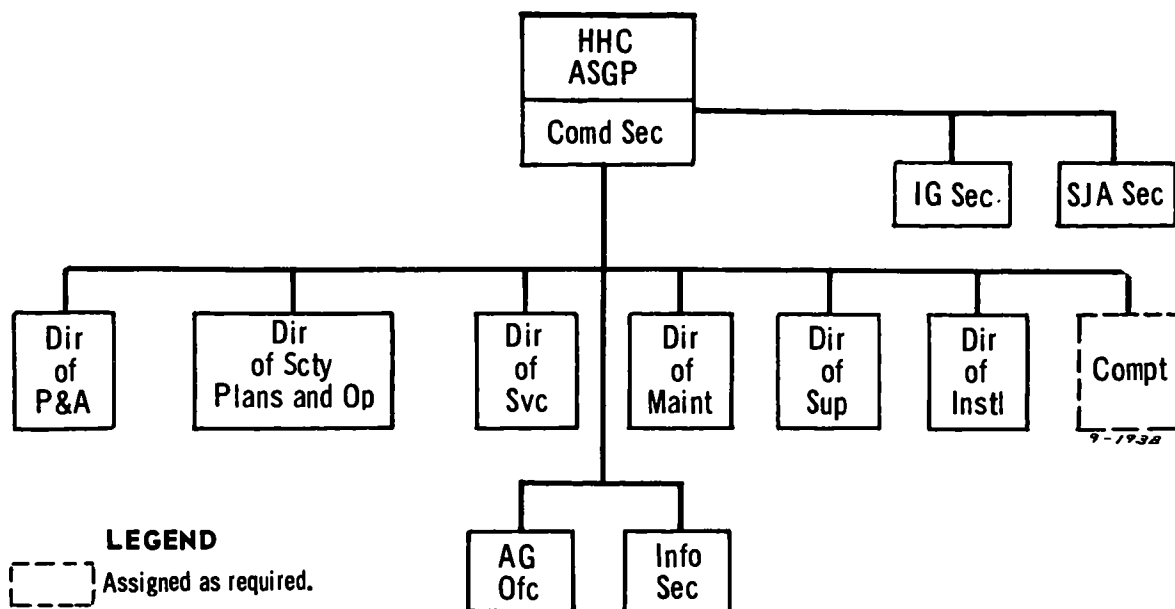

Figure 3-2. Headquarters and headquarters company, area support group.

sections of the ASCOM headquarters. The ASGP commander may delegate operational control authority to his principal staff officers (directors) over subordinate units that perform combat service support missions within their functional areas of staff responsibility.

c. Organization. Figure 3-2 depicts the organization of headquarters and headquarters company, ASGP.

d. Command and Staff Relationships. Command and staff relationships as described in FM 101-5 apply to ASGP headquarters.

3-4. Responsibilities and Duties of the ASGP Staff

ASGP headquarters analyzes missions; plans and allocates resources to subordinate units and directs deployment of units and installations; coordinates RAP matters; and, in general, insures the most efficient control and employment of personnel, materiel, and facilities in providing combat service support to designated forces. The staff elements of this headquarters perform the following functions. (Responsibilities and duties of staff officers as described in FM 101-5 apply to the ASGP staff and generally are not repeated in this section.)

a. The director of P&A—

(1) Analyzes personnel management data received from the supporting personnel services company and takes appropriate action.

(2) Coordinates group personnel actions with the supporting personnel services company.

(3) Assumes the following functions when a comptroller is not authorized in the ASGP:

(a) Reports control.

(b) Staff supervision over finance service.

b. A comptroller is added to the ASGP staff when higher headquarters determines it necessary. The comptroller advises and assists the commander on matters pertaining to finance service, management engineering, programing and budgeting, and internal review matters.

c. The director of security, plans, and operations—

(1) Provides guidance for RAP operations within the ASGP's jurisdiction and EOD and exercises operational control over them. RAP operation is covered in greater detail in FM 19-45.

(2) Provides staff guidance and planning for physical security activities.

(3) Supervises the operations of the rear area operations center (RAOC).

(4) Maintains liaison with civil affairs (CA) units operating in the ASGP area.

(5) Prepares, authenticates, and publishes operation plans and orders for the command, using input from other staff sections.

d. The director of installations—

(1) Advises and assists the ASGP commander in all matters pertaining to engineer support and directs the operations of engineer units assigned or attached.

(2) Prepares, coordinates, and implements plans and policies for real property maintenance activities (RPMA) including operation of utilities, maintenance and repair of real property, minor construction, and other engineering support (fire prevention and protection, refuse handling, and engineering management services).

(3) Plans and coordinates requirements for installation support operating stocks.

(4) Prepares and coordinates the group construction program, including approved requests from using units, for submission through command channels to TASCOC.

(5) Prepares, coordinates, and implements TASCOC plans and policies for minor new construction. (The limits of minor new construction will be stated in the theater construction program. Only that minor new construction which does not affect the established programs and priorities will be undertaken.)

(6) Plans, coordinates, and directs real estate operations to include survey, inventory, recording, and disposition.

(7) Provides liaison with supporting construction units and performs technical inspection of completed construction as a precondition to acceptance by the ASGP.

(8) Recommends changes to the engineer troop basis.

e. The director of services—

(1) Exercises staff supervision over communication service as it applies to operations.

(2) Exercises staff supervision over transportation and construction services.

f. The director of supply—

(1) Exercises supervision over supply

support operations of the group in accordance with ASCOC plans, programs, and policies.

(2) Establishes supply levels based on directives of higher headquarters.

(3) Implements policies, priorities, allocations, and criteria for controlled items.

(4) Coordinates and controls small local purchases and coordinates with other TASCOC commands, as appropriate, on local procurement.

g. The director of maintenance—

(1) Exercises supervision over maintenance support operations of the group, including repair parts supply to supported units, in accordance with ASCOC plans, programs, and policies.

(2) Recommends realignment of support missions of the maintenance battalion units as necessary to compensate for excessive workloads.

(3) Recommends increases in group maintenance capability or changes in the support mission of the group as necessary to balance workloads.

(4) Assists subordinate maintenance units in determining standards to employ in the establishment of appropriate production and quality control techniques and in the resolution of problem areas that develop, to include those related to facility, personnel, repair parts, and special equipment requirements.

(5) Insures conformance with priorities established for operational readiness support and issuance of operational readiness float stocks.

h. The adjutant general's office provides internal administrative services to the ASGP headquarters to include a distribution center, reproduction facilities, central classified document control and repository, forms management, and library service for headquarters correspondence and publications. It coordinates with the servicing Army Post Office (APO) for receipt and dispatch of headquarters official mail and coordinates and provides liaison with the servicing central records library for difficult or specialized records not retrievable by headquarters staff sections with their input-output devices. It operates under the staff supervision of the director of P&A.

Section III. PERSONNEL SERVICES

3-5. General

a. Mission and Functions. The director of P&A supervises activities that provide the following support: chaplain, postal, band, special services, law and order, labor, and miscellaneous personal services.

b. Director of P&A. Besides coordinating routine group personnel actions (the primary source of personnel service support is the ASCOM P&A battalion) and internal administrative services for the ASGP headquarters, the director of P&A is the coordinating staff officer for separate TOE units that perform the functions listed in *a* above and exercises supervision thereof.

3-6. Concept of Operation

a. Chaplain Services. The staff chaplain advises the commander and staff on all matters of religion, morals, and morale as affected by religion and operates a religious program for the group and such other chaplain support activities as directed.

b. Postal Services. The ASGP APO (TOE 12-550) operates under the supervision of the director of P&A. The APO locates its teams throughout the area supported. The mail processing team receives bulk mail from and dispatches bulk mail to personnel command (PERSCOM) general support (GS) postal units. The mail processing team processes incoming mail for units served. Troop units receive their mail from the incoming APO mail processing team. Outgoing continental United States (CONUS) mail is not sorted by the mail processing team (sorting mail by zip code is accomplished in CONUS). Postal finance teams provide postal services other than mail handling for units and individuals served. The APO headquarters team is responsible for accounting for postal moneys and postal effects.

c. Army Band. The band (TOE 12-107) provides band music for military ceremonies and special services activities conducted within the ASGP area. It also provides support to

units on the on-call basis and provides "combos" for special services rest areas.

d. Special Services. A service team of the special services detachment (TOE 12-18) provides a rest area. The rest area, supervised by one team, can provide facilities for rest and relaxation for a maximum of 750 personnel. Additional special services teams are assigned to the ASGP on an as-required basis. Other units must support the team to provide such additional support as chaplain, finance, postal, exchange, bath, and medical.

e. Law and Order. The headquarters and headquarters detachment, military police battalion, and its assigned or attached units maintain law and order by providing—

- (1) Control of traffic.
- (2) Crime prevention.
- (3) Criminal investigation.
- (4) Circulation control of individuals.
- (5) Assistance in RAP.
- (6) Confinement facilities for military personnel.

f. Labor Service. Although staff supervision of labor service rests primarily with the director of P&A, all other staff sections are concerned with the use of labor within their functional areas. The labor service organization and functions include—

(1) Teams (TOE 20-20) to provide command, administration, and labor supervision of non-U.S. labor elements which are assigned to the ASGP.

(2) Procurement of labor, training, relocation, housing, safety standards, policies regarding wages and hours of work, unemployment subsidies, compensation for injuries, and like matters which are governed by higher headquarters and the applicable provisions of law.

(3) First-line supervision, transportation to and from worksite, and provision of work tools which are responsibilities of the using unit.

Section IV. MAINTENANCE SERVICES

3-7. General

A maintenance battalion normally performs the DS maintenance and repair parts supply portion of the group mission. This battalion contains a headquarters and headquarters detachment; one or more maintenance support companies, COMMZ; and, if required, one or more transportation aircraft maintenance DS companies. These units provide DS maintenance and repair parts support to units in or passing through the COMMZ. When less than three maintenance companies are assigned to an ASGP, a battalion-type organization using a battalion headquarters and headquarters detachment is not employed. Instead, the maintenance companies operate directly under the supervision of the ASGP director of maintenance. Maintenance elements provide DS maintenance services by performing the following functions:

- a. Equipment repair, to include automotive, construction, electrical generation, refrigeration, air compressor, electronic, chemical, small arms, materials handling equipment, office machines, and heavy canvas and leather items.
- b. Direct exchange (DX) of serviceable for unserviceable components.
- c. Issue of repair parts.
- d. Technical inspection of equipment and materiel.
- e. Evacuation of unserviceable equipment to designated supply and maintenance command (SMCOM) field depots.
- f. Classification and evacuation of unserviceable items.
- g. Technical assistance and advice to supported units.

3-8. Concept of Operations

a. The maintenance workload of group maintenance units is predicated on mission assignments that group headquarters directs. The ASCOM assigns group responsibility for providing maintenance support to all units within or passing through a specified area. Each maintenance battalion deploys its subordinate units in a manner best designed to sat-

isfy support requirements in its area and assigns support missions to the maintenance companies. However, instructions and guidance that affect the operations of maintenance support companies are provided through command channels (e.g., ASCOM to ASGP, to maintenance battalion, to maintenance support company).

b. The director of maintenance and his staff exercise supervision of group maintenance operations.

c. Maintenance management guidance relative to recurring and special reports, the army equipment records system (TAERS) data usage, and related maintenance management information is available to operating maintenance units from the maintenance management center (MMC). A direct line of communications exists between the maintenance battalion of the ASGP and the ASCOM headquarters MMC and the automatic data processing center (ADPC).

3-9. Organizations and Capabilities

a. A maintenance battalion (fig. 3-3) and assigned or attached maintenance units provide DS maintenance support within the ASGP. This support is furnished on an area basis to units located in the COMMZ or passing through it. Medical materiel, ammunition, cryptomateriel, U.S. Army Security Agency (USASA) materiel, airdrop equipment, and light textiles and footwear are excluded from this support.

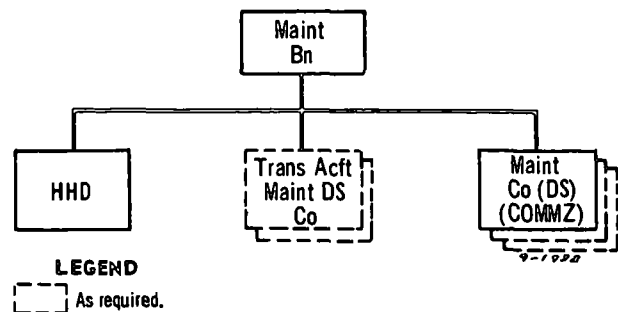

Figure 3-3. Maintenance battalion, area support group.

b. Headquarters and headquarters detachment, maintenance battalion (TOE 29-136), provides command and control and technical, administrative, and operational supervision of assigned or attached units. It can command and direct the operations of from three to seven maintenance companies which will include any required combination of maintenance DS companies, COMMZ, and transportation aircraft DS maintenance companies. This headquarters is assigned on the basis of one per ASGP when three or more maintenance companies are assigned to an ASGP.

c. The maintenance company (DS) (COMMZ) (TOE 29-427) provides DS maintenance of all equipment except medical, ammunition, cryptomaterial, aircraft, airdrop equipment, light textiles, and footwear. This company can perform equipment repair, DX of unserviceable components, issue of repair parts, technical inspection of equipment and materiel, evacuation of unserviceable equipment, and

classification of salvage items. These units are attached to the headquarters and headquarters detachment, maintenance battalion, when required, or operate directly under the ASGP headquarters.

d. The transportation aircraft DS company (TOE 55-457) provides DS Army aircraft maintenance, supply, and recovery support. Assignment to an ASGP is predicated on equipment density. When used, this company may be attached to a headquarters and headquarters detachment, maintenance battalion; or it may operate directly under the ASGP headquarters. Support provided includes DS maintenance, supply and aircraft recovery support; on-call mobile maintenance teams for onsite support of aircraft; and maintenance of the prescribed supply level of aircraft parts for types of aircraft supported.

e. FM 29-22 contains details on organization and operations of ASCOM maintenance support units.

Section V. TRANSPORTATION SERVICE

3-10. General

The transportation service organization provides motor transport for the ASGP to meet local routine and recurring requirements. In fulfilling its mission, the transportation service organization provides motor transport to accomplish the following functions:

a. Intragroup shipments of cargo and personnel.

b. Daily distribution of supply to supported units and other transportation when required.

3-11. Concept of Operation

a. Transportation service is furnished the ASGP from two sources:

(1) A light-medium truck company and a car company attached to the ASGP. The light-medium truck company and the car company provide motor transport to meet local routine and recurring requirements in support of the entire ASGP. These companies provide a means for intragroup shipment of cargo and personnel and daily distribution of supplies to

support units. These units are not employed for intradepot operations. The light-medium truck company and the car company are employed under the staff supervision of the ASGP director of services. He receives transport requirements for local transport from all activities of the group and commits the capabilities of the companies to accomplish the moves. The director of services relays requirements for local transport in excess of the ASGP's capabilities to the transportation movements office (TMO) located in the group area for accomplishment.

(2) The transportation command (TRANSCOM) which furnishes motor, rail, and air transport service, as required. The motor, rail, and air transport capabilities of the TRANSCOM provide backup support for the ASGP. Requirements for backup motor, rail, or air transport are placed on the local TMO by the shipping activity. The TMO determines the type of support to be furnished based on the characteristics and priorities of the shipment.

b. Normally, only the main highway supply routes and certain essential feeder routes are regulated in the COMMZ. The TRANSCOM highway traffic headquarters exercises control of the routes. Requests for movement over those routes are made to this headquarters through local TMO's or highway regulating points.

3-12. Organizations and Capabilities

a. The transportation car company (TOE 55-19) consists of three platoons, equipped with sedans, 1/4-ton trucks, 3/4-ton trucks, and

trailers. When augmented, this unit provides drivers for 24-hour operation. Assignment of one company per ASGP provides support to these headquarters and other units on an area basis.

b. The transportation light-medium truck company (TOE 55-67) is equipped with sixty 2 1/2-ton trucks and ten 5-ton tractors with twenty 12-ton semitrailers to provide general transport for personnel and equipment. The availability of two trailers per tractor provides flexibility in supporting shippers and receivers. It is assigned on the basis of one per ASGP.

Section VI. SUPPLY AND SERVICES

3-13. General

The supply and service organization provides DS supply and services (less classes V and VIII and those items associated with COMSEC, marine and rail peculiar-type equipment, and items peculiar to airdrop) by performing the following functions:

- a. Supply distribution.
- b. Clothing supply (to include storage and issue of impregnated chemical, biological, and radiological (CBR) protective clothing).
- c. Army exchange sales.
- d. Laundry and emergency impregnation of protective clothing.
- e. Renovation.
- f. Bath.
- g. Food service.
- h. Petroleum, oil, and lubricants (POL) distribution.
- i. Graves registration.
- j. Bakery services.
- k. Decontamination services.
- l. Disposal and salvage.
- m. Chemical and biological (CB) technical escort services.

3-14. Concept of Operation

The supply and service organization is determined by the nature of the mission of the particular ASGP to which the supply and service elements are assigned.

a. *Supply Operations.* The assigned DS supply and service companies provide supply of class I, II, III, IV, VI, and VII items. The

SMCOM provides ammunition support. Ammunition DS units may be assigned to the ASGP if consumption rates warrant such assignment. The commanding officer of the supply and service company is responsible for maintaining these levels through requisitions on the SMCOM. The supply and service company initiates requisitions and transmits them to the SMCOM inventory control center (ICC).

b. *Service Functions.* The DS supply and service company provides laundry, bath, renovation, graves registration, and salvage as its major service functions. A decontamination team and a salvage and service platoon provide the additional functional capabilities, as required. The decontamination capability is provided by the attachment of one or more FB decontamination teams from TOE 3-500.

c. *Local Procurement.* SMCOM provides central procurement of supplies and nonpersonal services, except those that are the responsibilities of other commands. DS procurement of supplies and nonpersonal services is limited to small, local purchases supported by an imprest fund or petty cash account. Suitable staffing is provided for a purchasing and contracting element in the director of supply section, ASGP headquarters. The real estate division of the director of installations section, ASGP headquarters, accomplishes the local procurement of real estate.

d. *Property Disposal.* Reportable excess personal property is evacuated through supply channels to designated field depots. All other

excess personal property will be given local area screening by the SMCOM ICC prior to disposal in accordance with the ASCOM standing operating procedure (SOP). When contractual services are involved in any disposal action, the group purchasing and contracting officer, with legal service provided by the judge advocate, provides contracting services.

3-15. Organizations and Capabilities

a. Headquarters and headquarters company, supply and service battalion (TOE 29-146), supervises two or more supply and service companies and other service-type units. The headquarters and headquarters company, supply and service battalion, is assigned to the ASGP, when required. It can provide support for from 15,000 to 30,000 nondivisional troops, depending on the number of subordinate operational units assigned or attached or both. The battalion headquarters may exercise centralized control of supply operations by consolidating supply personnel and equipment of com-

pany supply offices in the battalion operations section.

b. The supply and service company (TOE 29-147) is the basic operational element in the supply and service structure. It may be attached either directly to an ASGP or to a supply and service battalion. The company is designed to provide DS supply and service for nondivisional troops in either the field army or the COMMZ. The company contains a headquarters; a supply office; a supply platoon, to include a bakery section; a laundry, renovation, and bath platoon; a petroleum platoon; a graves registration section, an organizational section; and when employed in the COMMZ, an attached decontamination team FB and a salvage and service platoon. The company operates supply points to receive, store, issue, and distribute class I, II, III, IV, and VII supplies except communications security (COMSEC), airdrop items, and aircraft.

Section VII. INSTALLATION SUPPORT

3-16. General

a. *Engineer Installation Support.* Engineer installation support in the COMMZ is accomplished by engineer service teams (TOE 5-500 series) attached to the ASGP. This support is designed to provide a completely flexible post engineer planning and operational capability that can be reinforced or reduced in strength in response to varying requirements. By concentrating the more or less static engineer tasks under the ASGP, the necessity to divert engineer construction units for this work is eliminated and results in more effective use of engineer resources.

b. *Mission and Functions.* In providing support to units that the ASGP services, the installation support organization furnishes the following services:

- (1) Operation and maintenance of utilities.
- (2) Repair and minor alterations of buildings, grounds, and utilities within the ASGP area.
- (3) Fire protection service.

- (4) Sewage and trash disposal.
- (5) Installation water supply.
- (6) Real estate services.

3-17. Concept of Operation

The ASGP performs installation support functions through a director of installations, who is delegated responsibility and operational control to plan and execute assigned tasks.

a. The director of installations section operates with varying numbers of engineer service teams to maintain, repair, and make minor alterations to buildings, grounds, and utilities within the area of the ASGP and to provide real estate services.

(1) The administrative services division provides office services to the director and may also process work order requests that exceed the capabilities or authorization of the utilities teams.

(2) The engineering and plans division is the engineering and master planning office for the director. Many job order requests pass through this office for design work before re-

turn to the field. Construction plans to meet known or anticipated area support requirements are also prepared here for transmission to TASCOM and the engineer command (ENCOM). This office also prepares plans for alterations to existing structures for the utilities teams to execute.

(3) The operations division prepares orders, directives, and policies for installation support in all phases including repair and maintenance of streets, railroads, local Army air-landing facilities, buildings, and utilities; operation of water supply, sewage disposal, and electric power distribution; and fire prevention and protection. This division provides staff supervision of all these activities.

b. Construction Support.

(1) The ENCOM provides both general and direct construction support to the ASCOM in accordance with TASCOM directives and policies. Construction forces operating in the area of responsibility of an ASGP receive installation support in the same manner as other operating units, taking over only those self-support activities mutually agreeable to the area commander and the ENCOM.

(2) Installation support involves frequent requirements in an active theater for construction or rehabilitation of facilities that exceed the capabilities of the engineer utilities organizations. These are over and above those construction tasks contained in the theater construction program and may arise for a variety

of reasons. Decisions are made to categorize those construction tasks which arise and are not part of the theater construction program. If categorized as minor new construction or rehabilitation, they may be accomplished by the engineer units in GS. If the tasks exceed the limits of minor new construction or rehabilitation, as prescribed by the theater commander, a construction project request must be submitted for approval and subsequent inclusion in the theater construction program as discussed in (3) below.

(3) ASGP headquarters is responsible for preparing the construction program for all facilities in the group area. Therefore, this headquarters serves as the focal point or channel through which all actions concerning the construction program must pass. Regardless of the command channels involved, all requests for construction in the group's area of responsibility are forwarded to ASGP headquarters, where the director of installations takes necessary staff action in accordance with policies established by higher headquarters. Such an arrangement requires the director of installations to closely monitor construction needs and activities throughout the group's area of responsibility.

3-18. Organizations and Capabilities

FM 101-10-2 and appendix B of this manual contain details of the installation support teams.

Section VIII. MILITARY POLICE SUPPORT

3-19. Mission and Functions

In accomplishing its primary mission of the maintenance of discipline, law and order, the military police support organization conducts the following operations in each ASGP: military police stations, consisting of a military police desk, a radio net control station, and a con-

finement facility; patrols and posts; criminal investigation; traffic control; circulation control of individuals; and assistance of RAP.

3-20. Organization

Detailed discussion of military police organization in the ASGP appears in chapter 6.

Section IX. FINANCE DIRECT SUPPORT

3-21. General

The ASCOM, using finance direct support companies (FDSC) (TOE 14-17), provides finance

support to nondivisional units located in the COMMZ. FDSC are assigned to the ASGP's under ASCOM headquarters and provide

finance service on an area/population basis. FM 14-3 provides a detailed discussion on the mission, functions, and command relationships of the FDSC.

3-22. Concept of Operation

a. The company is employed to provide finance service to nondivisional elements of a field army, a corps, a special task force, or a

COMMZ within a specific geographical area or installation. Forward service teams (FST) may be organized under a mobile team concept to provide onsite financial service to organizational elements located at varying distances from the FDSC.

b. Provision for the continuing support of the FDSC remains a responsibility of the command to which assigned.

Section X. OTHER SUPPORT SERVICES

3-23. Communication Support

a. General.

(1) *Mission and functions.* The signal small headquarters operations company (TOE 11-147G) provides internal signal communication facilities and photographic service for the ASGP headquarters. Functions performed include installation and operation of manual telephone central office and local telephone systems; provision of secure radio teletypewriter, cryptographic facilities, and a message center; operation of ground messenger services; still and motion picture coverage (except air); and processing of ground and air still photographic coverage (except air combat surveillance).

(2) *Command relationships.* The theater army signal group, U.S. Army Strategic Communications Command (USASTRATCOM) (theater), exercises command and operational control over supporting signal units. The supporting signal operations company is attached for administrative support to the ASGP.

b. *Concept of Operation.* The signal small headquarters operations company installs, operates, and maintains a terminal-type communications facility at the supported headquarters. This company performs organizational and DS maintenance of its organic signal communication and photographic equipment. This unit depends on other signal units for trunking facilities (long lines) and on TOE 11-500 teams for additional signal communication capabilities, when required.

3-24. Medical Service

a. *General.* The ASGP has no medical units assigned or attached and must receive medical

support (to include dispensary service, evacuation, and hospitalization) from medical command (MEDCOM) facilities on an area basis. This concept of medical service involves the delineation of support responsibility by geographical area. It includes the provision of unit-level medical service to organizations that have no organic medical service personnel and the provision of required higher levels of support. Medical support under this concept is referred to as "area medical service" and is the method normally used for the support of COMMZ troops. Medical units required for this service are allocated based on troop strength and are established when troop concentration dictates. The senior medical commander located within the boundaries of an ASGP will normally provide medical staff advice for the ASGP commander.

b. *RAP Medical Support.* The senior surgeon located within the boundaries of an ASGP normally is responsible for designating a medical liaison representative to develop medical RAP plans to furnish the medical support for the ASGP commander's RAP plan. Once developed, the medical RAP plans are coordinated with the MEDCOM to insure availability of adequate medical means to accomplish all assigned missions.

3-25. Military Intelligence Support

a. *General.* A military intelligence detachment attached to each ASGP operates under the director of security, plans, and operations, receiving technical assistance and supervision from the military intelligence group headquarters normally collocated with ASCOM headquarters. Certain military intelligence opera-

tions concerning the entire COMMZ, e.g., movement control of suspected enemy agents, are freely coordinated among all headquarters to insure expeditious and timely coverage. Maximum cooperation/coordination with the military police units is maintained through direct liaison.

b. Organizations and Capabilities. Chapter 4 contains a discussion of the organizations and capabilities of military intelligence support in the ASGP.

3-26. BOD Support

a. General.

(1) *Mission and functions.* EOD detachments are designed to locate, identify, render safe, remove, and destroy explosive ordnance, including munitions containing chemical or biological agents or nuclear fission material, both domestic and foreign, that constitutes a hazard or detriment to military and civilian operations and personnel.

(2) *Organization.* EOD support for the ASGP is provided by an EOD detachment (GA) (TOE 9-520).

(3) *Command relationships.* Staff supervision and operational control of the EOD detachments are exercised by the EOD control detachment (GB) assigned to the ASCOM. Normal staff relationships exist with other headquarters and units.

b. Method of Operation. Requirements for EOD service are reported to the group RAOC. RAOC reports the requirement to the EOD control detachment. The control detachment reports the requirement to the disposal detachment responsible for providing support in that geographical area. Within the limits of established policy, requirements may be reported directly to the disposal detachment. FM 31-45 contains detailed information.

3-27. RAP

a. RAP, encompassing the functions of rear area security (RAS) and area damage control (ADC) and the associated political considerations, is the responsibility of the ASCOM commander. The ASGP accomplishes these functions through the assigned RAOC.

b. The RAOC is under the general staff supervision of the director of security, plans, and operations and keeps the ASGP commander informed of the current situation and of the resources available (RAP potential) to cope with emergencies. The RAOC provides the ASGP commander a planning and operational employment capability for forces designated to execute RAP missions.

c. The RAOC (TOE 29-408G) is organized as follows:

(1) A center headquarters directs, coordinates, and supports the activities of the other organizational elements.

(2) An administrative and logistic section provides the necessary command and supervision for the center's enlisted personnel and facilitates unit-level support to include administration, mess augmentation, organizational support and maintenance, security, training, and communication support for the operations center.

(3) A security, plans, and operations section is designed and staffed to provide the ASGP commander with current information of the situation in his area and of the resources available to cope with RAP emergencies. It provides the area headquarters, all tenant units, and adjoining RAOC's with pertinent information and assistance. This section supervises and coordinates plans and operations concerned with RAS/ADC activities. It implements the RAP policy and plans of the supported headquarters.

(4) A RAS task force command section provides for planning and control for RAS emergencies. It also supervises all RAS functions. This section includes a task force commander who, when directed, assumes operational control over activated RAS potential.

(5) An ADC task force command section provides for ADC planning and coordination and for control, training, and rehearsing of ADC forces. It provides for inspection and supervision of all ADC functions. This section includes the task force commander who, when directed, assumes operational control over ADC potential.

d. FM 19-45 provides the basic reference and detailed discussion of RAP.

CHAPTER 4

MILITARY INTELLIGENCE GROUP, COUNTERINTELLIGENCE

Section I. GENERAL

4-1. General

a. Mission and Functions. The military intelligence group, counterintelligence, is assigned to area support command (ASCOM). It provides military intelligence specialist support to theater army support command (TASCOM) for the security of U.S. personnel and installations within the TASCOM area. The group accomplishes its mission by—

(1) Supporting TASCOM, ASCOM, and its subordinate area support group (ASGP) by providing specialized assistance in the field of counterintelligence.

(2) Commanding, controlling, and supervising operational, administrative, and logistic functions of subordinate elements.

(3) Planning operations against a hostile clandestine threat whose activities transcend ASGP boundaries for the purpose of achieving maximum security for army units and installations within the TASCOM area and to achieve maximum neutralization of hostile espionage activities.

(4) Exercising centralized control and management of special operations in the areas of counterespionage, countersabotage, and countersubversion within the TASCOM area.

(5) Supervising the operation of a central record facility on personnel intelligence interest for TASCOM and other elements within the theater army.

(6) Exercising technical direction and supervision over centralized group intelligence operations.

(7) Providing liaison with parallel U.S., host government, and allied nation intelligence and police activities.

(8) Exercising control of security investigations to include personnel security investiga-

tions (PSI) and complaint-type investigations (CTI).

(9) Supervising and coordinating security services to include counterintelligence surveys and inspections, security education and training programs, and technical surveys and inspections.

(10) Providing intelligence security support for army nuclear weapon systems and facilities.

(11) Coordinating the allocation of intelligence personnel resources, based on ASCOM priorities, functional requirements, and disposition of army units and hostile elements.

b. Organization. Figure 4-1 depicts the organization of the military intelligence group, counterintelligence.

4-2. Concept of Operations

a. The military intelligence group, counterintelligence coordinates its operations through direct liaison with the military intelligence battalion, field army; the military intelligence group, theater army; and the intelligence units supporting theater air force and theater navy. This group maintains liaison with intelligence and police services of host governments, allied nations, and the United States, and particularly with military police and civil affairs (CA) units that are primary sources of intelligence information. Host government agencies are responsible for clearance actions on indigenous labor force personnel requested by a TASCOM unit.

b. The military intelligence group, counterintelligence, is organized and trained to operate against the hostile clandestine threat. It exercises centralized control and management of counterespionage, countersabotage, and coun-

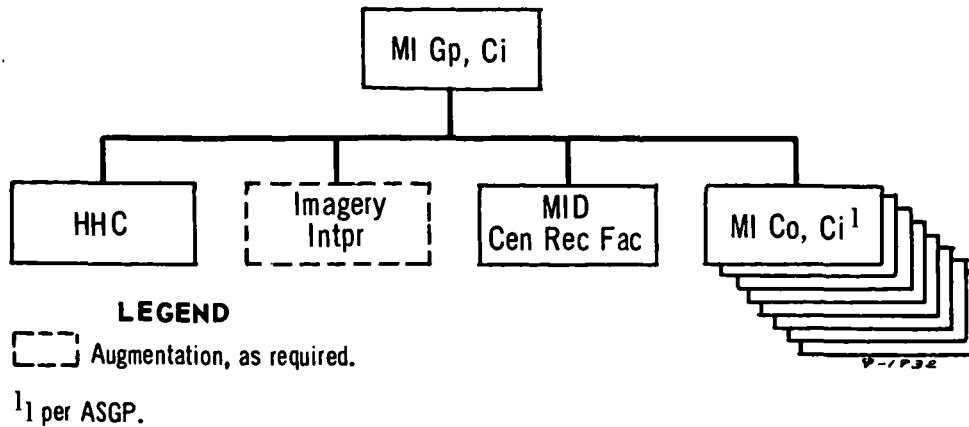

Figure 4-1. Military intelligence group, counterintelligence, ASCOM.

tersubversive operations within TASCOM. Further, this group is responsible for unified planning and operations against hostile elements whose activities transcend ASGP boundaries. As a result of these operations, this group can collect intelligence information on guerrilla forces; however, it cannot conduct reconnaissance against such forces.

c. The military intelligence group, counterintelligence, provides a single point of control for personnel security cases, which require a large number of investigations throughout theater army and continental United States (CONUS). This group exercises centralized control and management of personnel security actions within TASCOM. This group also assists TASCOM unit commanders in the exercise of their security responsibilities. The military intelligence group headquarters depends on the theater common-user signal system for communication with subordinate elements and on

the personnel and administration (P&A) battalion, ASCOM, for the production of P&A reports and the maintenance of P&A records.

d. The military intelligence group, counterintelligence, has no imagery interpretation capability. When an air reconnaissance and surveillance unit is assigned to ASCOM, a cellular-type (TOE 30-600) military intelligence detachment with appropriate imagery processing and interpretation capabilities is assigned.

e. The military intelligence group, counterintelligence, has no technical intelligence functions. Technical intelligence processing and intelligence production have been retained at theater army for the centralized support of all elements of theater army. ASCOM issues instructions to COMMZ elements on the notification procedure and evacuation of items of technical intelligence interest.

Section II. MILITARY INTELLIGENCE DETACHMENT, CENTRAL RECORDS FACILITY

4-3. General

This detachment maintains files on personnel of intelligence interest for theater army and provides direct support (DS) to theater army intelligence units. The detachment performs its mission by—

a. Receiving, screening, extracting, and filing reports from detachments of the military intelligence group, counterintelligence, and other intelligence units for theater army.

b. Opening new dossiers and updating existing dossiers with incoming reports.

c. Maintaining a central index and a dossier file.

d. In response to queries from within the group and from other theater army intelligence units, conducting file searches and providing DS to counterespionage, countersabotage, and countersubversive operations.

e. Maintaining operational files for the head-

quarters, military intelligence group, counter-intelligence.

4-4. Concept of Operations

The military intelligence detachment central records facility, normally is in the immediate vicinity of the headquarters of the group and

depends on the group for its administrative communication and combat service support. The detachment operates under the direct supervision of the group S3. It maintains its own message center and teletype terminal and provides its own control of classified documents.

Section III. MILITARY INTELLIGENCE COMPANY, COUNTERINTELLIGENCE

4-5. General

The military intelligence company, counterintelligence, conducts operations that will enhance personnel and installation security of U.S. personnel and facilities in the TASCOM area and reduce the hostile clandestine threat thereto. The company accomplishes its mission by—

- a. Conducting PSI's and CTI's.
- b. Conducting counterintelligence surveys, inspections, and technical inspections.
- c. Conducting counterespionage, countersabotage, and countersubversive operations.
- d. Processing requests for clearance of indigenous labor force personnel.
- e. Assisting ASGP in security education programs.
- f. Assisting in the screening of indigenous personnel for intelligence operational leads and for suspected guerrillas.

4-6. Operational Concepts

a. The military intelligence company, counterintelligence, is attached to ASGP for administrative support. It provides security support for ASGP and army units or facilities located within the ASGP area. Subordinate elements

of the company are located within the ASGP area with the larger groupings of service support units or at locations that facilitate counterintelligence operations. The disposition of personnel resources is based on requirements of the military intelligence group, counterintelligence, and the ASGP.

b. The company headquarters is in the immediate vicinity of ASGP headquarters. The military intelligence counterintelligence, company, depends on ASGP for normal combat service support. It coordinates with the director of security, plans, and operations in developing the command's security education program and develops schedules for participation. The director of security, plans, and operations levies installation security requirements on the companies. He also determines requirements for interrogation personnel and approves the disposition thereof. Unit requests for counterintelligence surveys, inspections, and technical inspections go to ASGP for approval and designation of priorities for accomplishment by the company. Resulting reports go directly to the requesting unit with information copies to ASGP.

c. Field manuals of the 30-series contain additional details for this company.



CHAPTER 5

CIVIL AFFAIRS BRIGADE, AREA SUPPORT COMMAND

5-1. Introduction

a. Civil affairs (CA) is a command responsibility and involves the relationship between the military commander and his forces and the civil authorities and people of a foreign country. CA operations cover the full spectrum of civil-military relationships ranging from advice, assistance, and civic action performed in a friendly country to military government operations in an occupied territory.

b. The nature of CA operations varies widely with the intensity of combat, the attitudes and status of the population in the area of responsibility, and the requirements of the tactical commander. In limited and general war, CA operations normally support the tactical situation directly. In stability operations, however, CA may be the primary mission of the military force because the ultimate objective is to gain the support of the populace for its government. CA input, with emphasis on execution, is a part of the planning for every military operation. This planning should consider the inherent capability, which every army unit possesses, to conduct CA operations. Planning should also provide for the employment of CA specialists and units to augment and support this inherent unit capability.

c. A CA brigade, when assigned to theater army support command (TASCOM), normally provides CA support in the communications zone (COMMZ). The TASCOM commander is delegated CA authority for the COMMZ. He may use the CA brigade headquarters as a TASCOM civil affairs command (CACOM), or he may further delegate the CA authority to the area support command (ASCOM) commander and assign the CA brigade to ASCOM. The CA brigade, regardless of assignment location, provides area support in the COMMZ and backup support to the field army CA units.

This brigade's subordinate units are assigned areas of responsibility dependent on densities of civil population, strength of indigenous government, and geographic or political boundaries. These units are normally the point of contact for relations with the local authorities and people. FM 41-10 and FM 100-15 contain more detailed discussions of CA in TASCOM.

5-2. Organization, Missions, and Functions

a. The CA brigade conducts operations that support the tactical situation and U.S. national objectives, including—

(1) Adequate control over the civil populace, displaced persons, and refugees.

(2) The location, protection, and control of civilian resources required for military operations and essential civilian support.

(3) Close liaison between tactical units and local authorities.

(4) The transfer of responsibility for CA functions, where appropriate, from the military commander to agencies of the local government.

b. CA is administered on a functional basis and should provide sufficient flexibility to fit the special requirements of any area or situation. Usual areas of specialization are those functions normally related to government, economics, public facilities, control of the populace and local resources, and social institutions. FM 41-10 further defines and explains the CA functions.

c. The following are the objectives of CA support—

(1) Establishment and control of local governments or provision of advice and assistance to them.

(2) Development of mutual understand-

ing and cooperation between the local populace and the U.S. forces.

(3) Execution of governmental, economic, and social programs to improve the lot of the indigenous population.

(4) Maintenance of law and order.

(5) Prevention of civilian interference with civilian support for U.S. military operations and the fostering of civilian support for these operations.

(6) Prevention of disease and unrest among the population.

d. When CA authority is delegated to the ASCOM commander, CA units assigned to the ASCOM provide CA support in the COMMZ. When three or more groups are attached to the ASCOM, a CA brigade may be established to facilitate command and control of CA operating units. These units also provide backup support to field army support command (FASCOM) CA units. ASCOM CA units may contain specialties not found in field army CA units. CA units in the COMMZ are assigned areas of responsibility depending on the military situation, densities of civil populations, self-sufficiency of indigenous governments, and geographic or political considerations. Initially, they have a minimum capability to achieve priority CA objectives. However, the assignment of additional CA teams or units as required and as the situation permits may and should expand this capability. CA companies, battalions, and groups are flexible and can be structured to accommodate the force supported, the area of deployment, and the specific operational environment. Teams from TOE 41-500 may supplement these units as the situation requires. Once established, the CA area support organizational structure within the ASCOM remains relatively stable to insure continuity of coordinated CA plans and operations of the ASCOM commander.

5-3. Command Relationships

The ASCOM commander normally will be delegated CA responsibility and authority. When this is the case, he exercises operational control over the CA units in his area. When the ASCOM commander has not been delegated CA authority, his responsibility consists of liaison

with CA units in this area and administrative support thereof. The CA brigade exercises command, or command less operational control, as designated, over all subordinate CA units.

5-4. Organizational Concepts

a. The organization of CA units is flexible and adaptable to the local military, political, economic, and sociological conditions encountered. Control of CA units may be centralized or decentralized depending on the type of operation being conducted. Operational control of CA units and teams normally is decentralized to the commander having area responsibility.

b. These units provide—

(1) Efficient command and control.

(2) Maximum use of technological skills.

(3) Flexibility with associated economy of personnel.

(4) Pooling of specialist personnel at the highest echelon of command consistent with the mission of the support force.

c. In normal employment, the CA brigade has attached three or more CA groups as its major operating units. The number of groups may be adjusted as required; however, when more than six groups are required, an additional brigade is organized for each four groups or major fraction thereof.

d. The headquarters, CA brigade (TOE 41-201) (fig. 5-1), controls all assigned and attached CA units conducting operations in the COMMZ.

e. Headquarters and headquarters detachment, CA group (TOE 41-500), provides a command and control element for the supervision and support of attached CA battalions and functional teams. Normally, from three to six battalions are attached to each CA group. Additional battalions may be attached as required; however, when more than six battalions are required, an additional group is organized for each four battalions or major fraction thereof. The CA group is a subordinate unit of the CA brigade. This group conducts CA operations in its designated area of responsibility, which may or may not coincide with that of an area support group (ASGP), depending on population densities, operational environment, and political or military bounda-

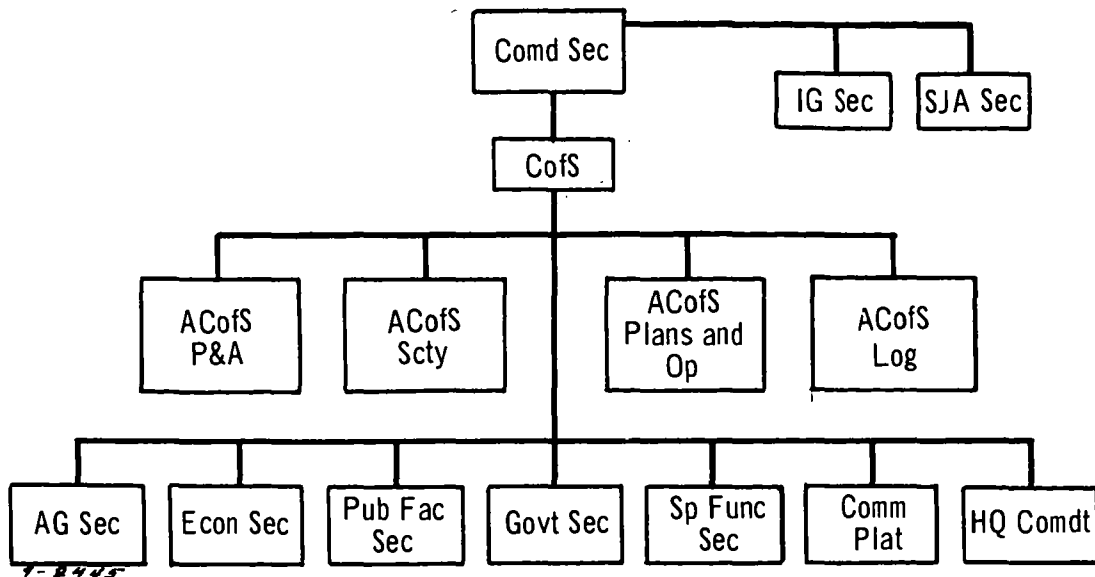

Figure 5-1. Typical staff, civil affairs brigade, ASCOM.

ries. However, one or more ASGP administratively support the CA group. This group's battalions normally are assigned areas of responsibility within the group's overall area of responsibility. When directed, the group can assume responsibility for dealing directly with heads of government at the state or provincial level or with government officials in large municipalities. When used in a province, its functional teams advise, assist, supervise, or direct, as appropriate, the departments of the provincial government. The group conducts CA operations in accordance with policies and directives from higher headquarters.

f. Headquarters and headquarters detachment, CA battalion (TOE 41-500), provides a command and control element for the supervision and support of attached CA companies and functional teams for battalion operations. Normally, from three to six CA companies are attached to each battalion. Additional companies may be attached as required; however, when more than six companies are required, an additional battalion is organized for each four companies or major fraction thereof. The CA battalion is a subordinate unit of the CA group. The battalion conducts CA operations in its designated area of responsibility. Compa-

nies are normally assigned areas of responsibility within the battalion's overall area of responsibility. The battalion may be assigned responsibility for CA area operations in a large city or a major subdivision of a province or it may function as part of a group. When directed, the battalion can assume the responsibility for dealing directly with indigenous government officials in its area of operations or in large cities, counties, districts, etc. The battalion conducts CA operations in accordance with policies and directives from the headquarters to which it is assigned or attached.

g. The CA company (TOE 41-500) provides a command and control element for supervision and support of attached CA platoons and functional teams for company operations. Normally, from three to 10 platoons are attached to each company. Additional platoons may be attached as required; however, when more than 10 platoons are required, an additional company is organized for each six platoons or major fraction thereof. The CA company is a subordinate unit of the CA battalion. This company conducts CA operations in its designated area of responsibility. It may be assigned responsibility for CA area support operations in districts, counties, and smaller cities or it

may function as part of a battalion. Platoons generally are located in small towns or with comparable levels of government.

h. Additional CA units and/or functional teams are requisitioned as required from the next higher headquarters in the chain of command.

5-5. Operational Concepts

a. Certain activities such as restoring public order and safety, controlling refugees and displaced persons, and furnishing emergency relief to the indigenous population have received primary attention during a fluid situation. They share importance with such functional activities of government as public works and utilities, civilian supply, civil information, and labor once a CA unit has taken over. It is essential to establish a stable government at all levels and to confirm its exercise of authority as soon as possible.

b. The degree of control exercised by the military commander over the indigenous population, its government, and economy of an area in which military operations are conducted depends on the nature of the operation, its objectives, U.S. national policy, and the effectiveness and acceptability of the existing civil administration. It may depend primarily on CA agreements or other agreements entered into on a nation-to-nation level. When civil government and its agencies are efficient, the military commander seeks to avoid interfering in government matters not having an immediate bearing on the tactical situation. On the other hand, if the civil administration has collapsed or is near collapse, the appropriate military commander may have to assume complete responsibility for the civil administration of his area. In such circumstances, the commander assumes a military government role within his assigned area of responsibility.

c. As the situation requires, the appropriate tactical or combat service support commander may direct subordinate units to provide support to CA operations. Specific assistance may include—

(1) Engineer support for rehabilitation of public health facilities, construction of dis-

placed persons' camps, or maintenance of essential civilian transportation facilities.

(2) Medical support for the control of disease, to include supply of medical items.

(3) Military police support for protecting critical facilities, controlling movement of civilians, enforcing curfew, and quelling riots.

(4) Transportation support to move critical supplies, to transport civilians, and to assist in reestablishing civilian transportation facilities.

(5) Signal support in rehabilitating civilian communication facilities.

d. When an area support CA unit replaces a command support CA unit, the commanders of the units concerned take necessary actions to familiarize the relieving unit with the current situation in its area of operation. These actions include—

(1) Informing the commander and staff of the relieving unit of the designations, locations, and commanders of higher, adjacent, subordinate, and supporting units in the area.

(2) Informing the commander and staff of the relieving unit of the characteristics and peculiarities of the area.

(3) Providing copies of current operational directives, orders, proclamations, standing operating procedures (SOP), and policy checklists.

(4) Providing copies of reports and records summarizing previous activities in the area of the unit being relieved.

(5) Describing activities in progress and their relative importance and pointing out additional measures to take.

(6) Documenting commitments made to civilians or civilian officials.

(7) Providing a list of individuals in office and those not appointed as officials who have been, and may continue to be, of value to the CA effort.

e. CA in the COMMZ should be attuned to the diverse sociopolitico-economic situations of the civilian communities within the area. The supporting CA unit of a military command is normally the point of contact for relations with the local authorities and people in the name of the military commander.

f. In all stability operations, plans include an

integrated and coordinated civil-military approach designed to progressively reassert governmental control and to gain the trust, confidence, and active cooperation of the population. The total effort should be conducted within a host-guest environment and must be

designed to support and strengthen the local government without usurping the powers and prerogatives of that local government.

g. FM 41-10 cites functions of staff sections and details of operational concepts and functions in CA units.



-

.



3

.



CHAPTER 6

MILITARY POLICE SUPPORT

6-1. General

FM 19-4 and FM 29-6 contain discussions of prisoner of war, civilian internee, crime laboratory, and stockade and rehabilitation operations.

a. Area Support Command. A military police brigade, as shown in figure 6-1, provides all the military police support required for the area-oriented military police missions of the area support command (ASCOM), the security and guard missions for the other theater army support commands (TASCOM), and the command headquarters security of the theater army and TASCOM headquarters. The ASCOM provides military police elements to the medical command (MEDCOM), transportation command (TRANSCOM), supply and maintenance command (SMCOM), theater army headquarters (TAHQ), and TASCOM headquarters.

b. Area Support Group. A military police battalion (composite), as described in paragraph 6-3, provides military police support within the confines of each area support group (ASGP). This battalion provides for area-oriented military police support, the operation of a small confinement facility, and investigation and prevention of crime.

6-2. Military Police Brigade, ASCOM

a. Mission and Functions. This brigade provides area-oriented, command headquarters-oriented, and function-oriented military police support throughout the communications zone (COMMZ). This includes providing support to the small military police battalions (composite) of the ASGP's. The brigade accomplishes its mission by—

- (1) Providing control and security of traffic.
- (2) Maintaining discipline, law and order.

- (3) Investigating and preventing crime.

- (4) Assisting in RAP activities.

- (5) Providing physical security, to include security of railroads and trains, general hospitals and convalescent centers, and command headquarters.

- (6) Providing movement security for critical and sensitive supplies and for designated individuals.

- (7) Assisting in quelling civil disturbances.

- (8) Providing assistance to the indigenous population in case of natural disaster.

- (9) Controlling the circulation of individuals, to include assisting the civil affairs (CA) brigade in controlling refugees and displaced persons.

- (10) Advising, assisting, and supporting indigenous paramilitary and military police forces, as required.

b. Concept of Operation.

- (1) The military police brigade provides military police support for the COMMZ. In addition, it provides direct support (DS) for the ASGP's, as required. Its primary concern is providing military police support in all areas not assigned as a direct responsibility of an ASGP. Within the ASGP's, this brigade provides traffic control on all routes designated as main supply routes (MSR). It also provides support for activities oriented toward the other TASCOM commands. Combat service support is provided by the ASGP in which the military police elements are operating.

(2) *Command relationships.*

- (a) *With ASCOM.* The military police brigade is assigned to the ASCOM and functions under the staff supervision of the ACofS, personnel; the ACofS, security, plans, and operations; and the ACofS, services.

- (b) *With ASGP.* In a normal operation,

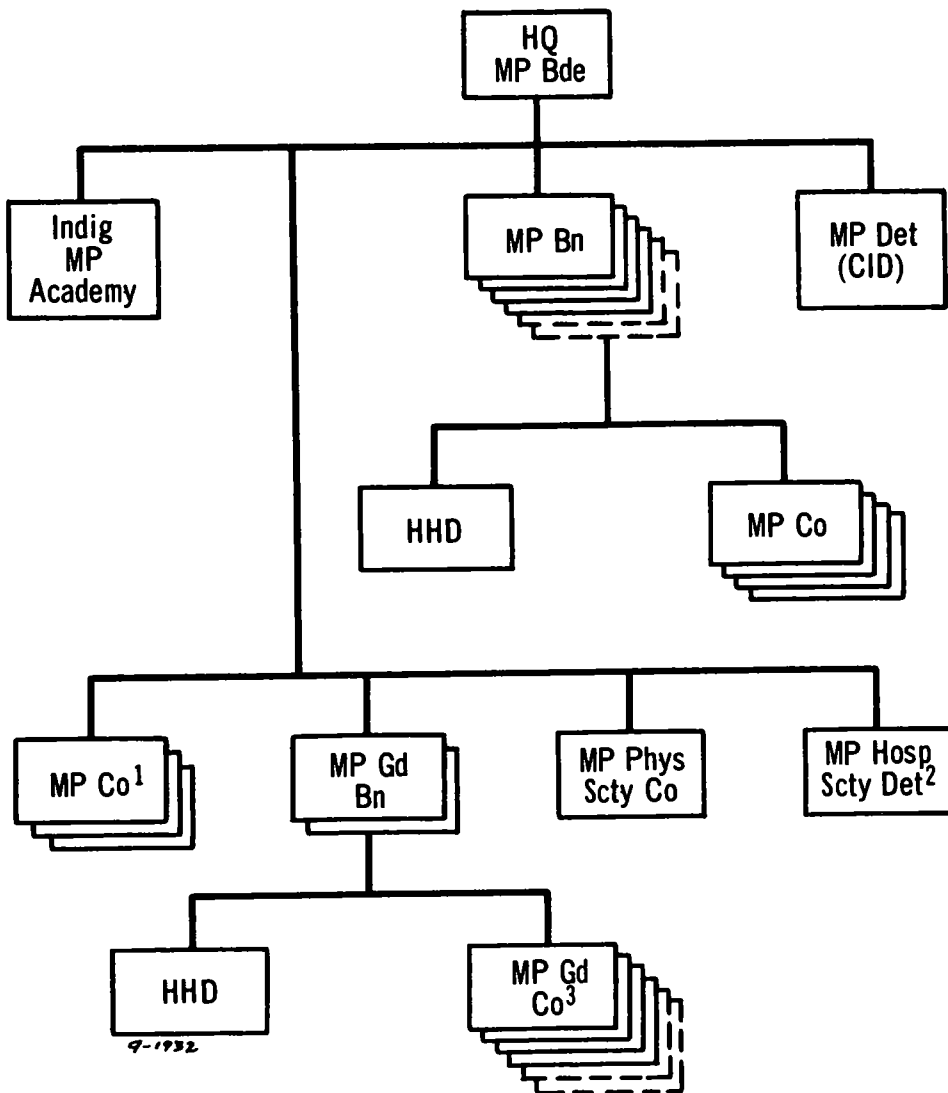

LEGEND

[- -] As required.

¹1 to TAHQ; 1 to TASCOP HQ.

²1 per GH and conv cen.

³1 per trans ry bn.

Figure 6-1. Military police brigade, ASCOM.

both the military police brigade of the ASCOM and the military police battalion of the ASGP may be operating in the same geographical area. This is normal and essential because of the missions assigned to each of the units.

Thus, at all times, close liaison must be maintained to insure complete harmony among the military police elements.

(c) *With units of other commands.* The brigade exercises direct coordination with the

military intelligence units of ASCOM and TASCOM and with the intelligence units supporting theater air force and theater navy. Liaison is maintained with intelligence and police services of host governments and with CA units that are a primary source of information.

c. Organizations and Capabilities.

(1) The headquarters and headquarters detachment, military police brigade (TOE 19-262) commands, plans, supervises, coordinates, supports, trains, and controls the operation of two or more military police battalions and all other assigned or attached units that provide military police service within the ASCOM.

(2) The headquarters and headquarters detachment, military police battalion (TOE 19-76), is organized as a command and control element for area-oriented operations. This detachment provides command, control, staff planning, criminal investigation, and support for combat service from two to six military police companies.

(3) The headquarters and headquarters detachment, military police battalion (team AD (TOE 19-500)), provides command and control for the functionally oriented responsibilities of the military police brigade, ASCOM; namely, railway guard operations for the TRANSCOM. It provides command, control, staff planning, and administration and combat service support for assigned and attached units.

(4) The military police battalion provides area-oriented and command-oriented military police support throughout the ASCOM area of operations.

(5) The military police company (TOE 19-77) provides area-oriented military police support in the COMMZ.

(6) The military police guard company (TOE 19-247) provides guard services for the protection of facilities, installations, railways, trains, pipelines, and inland waterways and for the custody of prisoners of war, civilian internees, and U.S. military prisoners.

(7) The military police physical security company (TOE 19-97) provides close physical security services for ASCOM installations and

facilities or operates as a rear area security (RAS) force.

(8) The military police criminal investigation detachment (team LC (TOE 19-500)) provides services required for the prevention and investigation of crime among military personnel and other persons subject to the Uniform Code of Military Justice (UCMJ).

(9) Military police hospital security detachment (teams IG, FD, and IC, (TOE 19-500)) provides security and police services to the convalescent centers and general hospitals of the MEDCOM.

(10) Selected military police detachments (teams AC, B, QD, QE, QG, QH, and NA (TOE 19-500)) advise, assist, and support indigenous paramilitary and military police.

6-3. Military Police Battalion (Composite), ASGP

a. Mission and Functions. The military police battalion (composite) provides local military police support within the confines of the ASGP by—

- (1) Performing traffic control (non-MSR).
- (2) Maintaining discipline, law and order.
- (3) Investigating and preventing crime.
- (4) Assisting in RAP activities.
- (5) Assisting in quelling civil disturbances.
- (6) Providing assistance to the indigenous population in a natural disaster.
- (7) When authorized, participating in combined operations with indigenous paramilitary and military police forces.

b. Organization. Figure 6-2 depicts the organization of the military police battalion (composite), ASGP.

c. Command Relationships. The military police battalion (composite) is a subordinate unit of the ASGP. It functions under the primary staff supervision of the director of personnel. The director of security, plans, and operations and the director of services have staff responsibility for specific areas; e.g., rear area protection (RAP) and traffic control. Close liaison is maintained with elements of the military po-

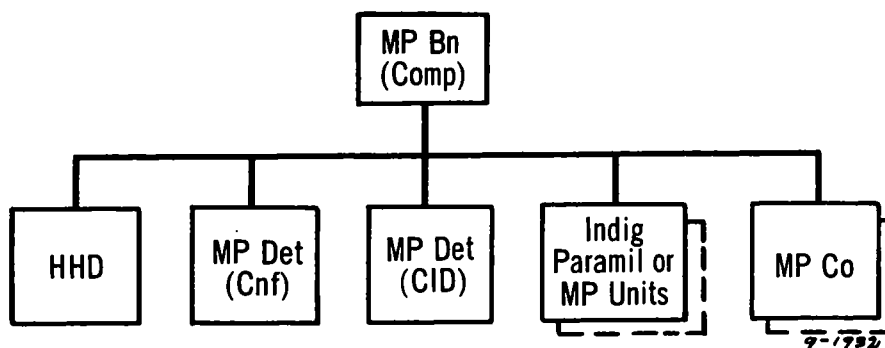
**LEGEND**

--- -As required.

Figure 6-2. Military police (composite), area support group.

lice brigade, ASCOM, operating within the ASGP area.

d. Operational Concepts. This military police battalion provides military police support to the ASGP to which it is assigned. It provides local military police services for those installations and activities in the support group area. When a military police unit is assigned or attached to another TASCOM command activity, that unit provides military police support within the installation or activity. For example, a military police physical security company attached to a special ammunition depot provides for internal police support within the perimeter of the depot. In addition to its discipline, law and order operations, this battalion is responsible for operating an ASGP stockade for the confinement of personnel who have short sentences or who are awaiting court-martial or transfer to a large COMMZ stockade or rehabilitation training center.

e. Organizations and Capabilities.

(1) The headquarters and headquarters detachment, military police battalion (team AD (TOE 19-500)) provides command, control, and staff planning for assigned and attached military police units.

(2) The military police company (TOE 19-77) can perform area-oriented, function-oriented, and command headquarters-oriented missions. It is primarily designed to perform area-oriented operations; however, since this

capability is sufficient for most of the function-oriented and command headquarters-oriented operations, it is also used for these purposes.

(3) The military police criminal investigation detachment (team LA (TOE 19-500)) provides services required for the prevention and investigation of crime among military personnel and other persons subject to the UCMJ.

(4) The military police correctional detachment (teams MA, ME, MF, MG (TOE 19-500)) provides for the command and supervision of the ASGP stockade. This detachment is augmented by guard teams for the security of prisoners. The detachment, as augmented by functional mess teams, provides for administration, custody, and control of a military prisoner population of approximately 40 individuals.

6-4. Command and Control Relationships

a. The military police command and control relationships within the ASCOM and those between the ASCOM and the TASCOM mission commands are delineated below.

b. The ASCOM military police brigade has area military police responsibility throughout the COMMZ. This responsibility includes providing support to the organic military police battalions of the ASGP's, as required. The ASGP military police battalion (composite) provides support for the area of responsibility assigned to the particular ASGP. As long as

the military police requirements remain normal, the command and control relationships consist of continuous coordination and liaison between the military police brigade elements and the military police battalions organic to the ASGP's. However, when the operational requirements within the ASGP are beyond the capabilities of the ASGP military police battalion, the military police brigade is responsible for providing the ASGP military police battalion with more military policemen or it assumes the responsibility for the requirement. The military police brigade provides additional military policemen to the ASGP military police battalion by assigning or attaching or by placing them in support of, or under the operational control of, the ASGP military police battalion. In some instances, especially when the requirement has little impact on the ASGP commander's mission, the military police brigade assumes full responsibility for the requirement and reports to the ASGP commander on completion.

6-5. Military Police in the ASCOM Headquarters

While RAP is not an exclusive function of military police and is, in fact, a function of direct responsibility of the ASCOM commander, one of the resources of the ASCOM for RAP missions is found in the military police brigade assigned to the ASCOM. Rear area operations centers (RAOC) designed to meet the requirements of missions are assigned to the ASGP. Officers and enlisted personnel specially trained in RAP operations are assigned to the office of the assistant chief of staff (ACofS), security, plans, and operations. FM 19-45 contains details on RAP.

6-6. Use of Indigenous Personnel

Indigenous personnel may be hired to perform duties and services to extend and improve U.S. military police capabilities; e.g., interpreting, translating, and guarding.



.

.



.

.



APPENDIX A

REFERENCES

A-1. Army Regulations (AR)

165-20	Duties of Chaplains and Commanders' Responsibilities.
310-32	Organization and Equipment Authorization Tables: Personnel.
320-5	Dictionary of United States Army Terms (Short Title AD).
320-50	Authorized Abbreviations and Brevity Codes.
(C) 381-143	Logistic Policies and Procedures (U).

A-2. Pamphlets (DA Pam)

310-series	Military Publications Indexes.
------------	--------------------------------

A-3. Joint Chiefs of Staff Publications

1	Dictionary of United States Military Terms for Joint Usage (Short Title: JD).
2	Unified Action Armed Forces (UNAAF).
(C) 3	Joint Logistics and Personnel Policy and Guidance (U).

A-4. Field Manuals (FM)

3-1 (Test)	Chemical, Biological, and Radiological (CBR) Combat Service Support TASTA-70.
5-142-1 (Test)	Construction Support to FASCOM.
5-162-1 (Test)	Engineer Command, TASCOM.
8-16-1 (Test)	Medical Service, Field Army.
8-17-1 (Test)	Medical Service, Communications Zone.
9-6-1 (Test)	Ammunition Service in the Theater of Operations, TASTA-70.
10-8-1 (Test)	Air Delivery of Supplies and Equipment in the Theater of Operations.
10-67-1 (Test)	Petroleum Supply in Theaters of Operations.
11-147	Signal Small Headquarters Operations Company.
12-2	Adjutant General Support in Theaters of Operations.
14-3	Comptroller Support in Theaters of Operations.
16-5	The Chaplain.
19-4	Military Police Support, Theater of Operations.
19-15	Civil Disturbances and Disasters.
19-25	Military Police Traffic Control.
19-30	Physical Security.
19-45-1 (Test)	Rear Area Protection.
27-4 (Test)	Judge Advocate Support in Theaters of Operations.
29-3-1 (Test)	Direct Support Supply and Service Operations.
29-6	The Personnel Command.
29-10-1 (Test)	The Field Army Supply Management System.

- 29-11 (Test) Cryptologistics Support to the Army in the Field, 1965-1970.
- 29-20 Maintenance Management in Theaters of Operations.
- 29-22 Maintenance Battalion and Company Operations (Nondivisional).
- 29-45-1 (Test) General Support Supply and Service in the Field Army.
- 31-45 Explosive Ordnance Disposal Service.
- 41-10 Civil Affairs Operations.
- 41-15 (Test) Civil Affairs Support, TASTA-70.
- 54-5-1 (Test) The Supply and Maintenance Command.
- 54-7 The Theater Army Support Command.
- 54-8 (Test) The Administrative Support Theater Army (TASTA-70).
- 55-4-1 (Test) Transportation Movements in a Theater of Operations.
- 55-6-1 (Test) Transportation Services in a Theater of Operations.
- 55-20 Army Rail Transport Operations.
- 55-35-1 (Test) Motor Transport Operations and Motor Transport Units.
- 55-46-1 (Test) Army Air Transport Operations.
- 55-50-1 (Test) Transportation Amphibian Operations.
- 55-55-1 (Test) Transportation Terminal Operations.
- 100-5 Operations of Army Forces in the Field.
- 100-10 Combat Service Support.
- 100-15 Larger Units: Theater Army—Corps.
- 101-5 Staff Officers' Field Manual: Staff Organization and Procedure.
- 101-10-1 Staff Officers' Field Manual: Organizational, Technical, and Logistical Data, Unclassified Data.
- 101-10-2 Staff Officers' Field Manual: Organizational, Technical, and Logistical Data, Extracts of Tables of Organization and Equipment.
- (S) 101-10-3 Staff Officers' Field Manual: Organizational, Technical, and Logistical Data, Classified Data (U).

APPENDIX B

TROOP LISTS, AREA SUPPORT COMMAND

B-1. General

Typical area support command (ASCOM) troop lists in support of TASTA-70 are based, in general, on an eight-division field army expandable to a 12-division field army.

B-2. Combat Service Support

The troop list below represents balanced combat service support forces in the communications zone (COMMZ). Many of the tables of organization and equipment (TOE) contained in these lists are currently under development. Refinements of TOE cause minor changes in overall totals.

B-3. Type B Units

Type B units have been used throughout the COMMZ resulting in an approximately 25-percent reduction in overall U.S. Army military strength from that required for full U.S. military staffing.

B-4. Requirements for Nonmilitary Personnel

Use of nonmilitary personnel permits expansion of the capabilities of company-size units to support increased requirements without the addition of whole companies.

B-5. ASCOM Organizations

These organizations are designed to support an eight-division force operating on a large landmass in a limited war. Headquarters units and control centers do not normally require increased strengths to support larger forces. Operating elements are increased to support greater workloads. Headquarters structures of area-oriented COMMZ organizations (area support groups (ASGP), military police) are not increased to support a larger force because the COMMZ area normally remains the same as for the eight-division force.

B-6. Typical Troop List: ASCOM in Support of an Eight-Division Force

<i>Unit</i>	<i>TOE</i>	<i>Approx str</i>	<i>Number</i>	<i>Total</i>
HHC & sp trps, ASCOM	54-402	394	1	394
ADP unit (type A)	29-540	56	1	56
HHC, ASGP	54-422	216	8	1,728
MI gp, ci	20-60	1,294	1	1,294
HHD, P&A bn	12-66	54	1	54
Pers svcs co (types A-E)	12-67	Various	7	1,292
Admin svcs co	12-570	84	1	84
Mess det, tm CA and CB	29-500	8	24	192
RAOC ¹	29-408	78	8	624
Sales det, tm BA, BB, and BC	10-500	19	8	152
Maint mgt det	29-403	32	1	32
S&S co, DS (type B)	29-147	190	8	1,520
Svc plat (type B)	29-114	4	8	32
SPS det, recr and entertainment, tm FA	12-18	8	11	88
Army band	12-107	29	8	232
APO	12-550	37	8	296
Cml det (decon), tm FB	3-500	41	8	328
Fin DS co	14-17	115	8	920

¹ Rear area operations center.

<i>Unit</i>	<i>TOE</i>	<i>Approx str</i>	<i>Number</i>	<i>Total</i>
Engr plat HQ, tm AB	5-500	4	8	32
Engr ftg HQ, tm FA	5-510	4	24	96
Engr fire trk, tm FB	5-510	6	120	720
Engr water trk, tm FC	5-510	2	24	48
Engr water purification, tm GG	5-520	4	104	416
Engr water purification (cen plant), tm GH	5-520	12	16	192
Engr util, tm HF	5-530	52	16	832
Engr real estate, tm HC	5-530	16	8	128
Trans lt-mdm trk co (type B)	55-67	89	8	712
Trans car co (type B)	55-19	64	8	512
Cen HQ, labor supv org	20-20	12	8	96
Dist HQ, labor supv org	20-20	8	80	640
Trans acft DS co	55-457	265	2	530
HHD, maint DS bn	29-136	63	8	504
Maint spt co, COMMZ (type B)	29-427	224	22	4,928
EOD det con (GC)	9-520	10	1	10
EOD det dspo, tm GA	9-520	13	8	104
HHC, CA bde	41-201	239	1	239
CA gp	41-500	226	3	678
CA bn	41-500	150	12	1,800
CA co	41-500	169	48	8,119
HHD, MP bde	19-262	72	1	72
HHD, MP bn	19-76	59	4	236
HHD, MP bn (comp), tm AD	19-500	7	10	270
MP co	19-77	186	26	4,838
MP gd co	19-247	127	8	1,016
MP phys sety co	19-97	143	10	1,430
MP cnf det, tm MD	19-500	35	8	280
CID det, tm LC	19-500	27	1	27
CID det, tm LA	19-500	4	8	32
Indig MP academy, tm AC, QB, QD, QE, QG, QH, and NA	19-500	28	1	28
MP hosp sety plat, tm FD, IC, and IG	19-500	38	18	684
JAG det, HQ, tm AD	27-500	9	1	9
JAG det, war crimes, tm GA	27-500	4	3	12
JAG det, war crimes, tm GB	27-500	5	0	0
JAG det, claims, tm FA	27-500	4	3	12
JAG det, claims, tm FB	27-500	10	0	0
JAG det, GCM, tm HA	27-500	6	5	30
JAG det, GCM, tm HB	27-500	10	3	30
JAG det, legal asst, tm IA	27-500	3	0	0
JAG det, legal asst, tm IB	27-500	4	1	4
JAG det, proc law, tm JA	27-500	14	0	0
				39,662

INDEX

	Paragraph	Page		Paragraph	Page
Adjutant general	2-13	2-4			
Ammunition	1-5b	1-2			
	(10), (11)				
Area support command (ASCOM):			Headquarters and headquarters detach- ment, CA battalion ...	5-4f	5-3
Command relationships	1-7	1-2	Headquarters and head- quarters detachment, CA group	5-4e	5-2
Functions	1-5b	1-1	Clothing supply. (<i>See</i> Supply and services.)		
Mission	1-5a	1-1	Combat service support	1-5d	1-2
Organization	1-6	1-2	Communication support	3-23	3-11
Area support command headquarters (ASCOM):			Comptroller	2-10	2-4
Functions	2-1b	2-1	Construction support. (<i>See</i> Installation support.)		
Mission	2-1a	2-1	Cryptologistics	1-5b(18)	1-2
Organization	2-2	2-2	Decontamination services. (<i>See</i> Supply and services.)		
Staff duties	2-3-2-14	2-2	Disposal and salvage. (<i>See</i> Supply and services.)		
Area support group (ASGP):			Explosive ordnance disposal	2-23, 3-26	2-7, 3-12
Command relationships	3-1c	3-1	Finance direct support:		
Concept of operation	3-2	3-1	Concept of operations	3-22	3-11
Mission and functions	3-1a	3-1	General	3-21	3-10
Organization	3-1b	3-1	Food service. (<i>See</i> Supply and services.)		
Area support group headquarters (ASGP):			Graves registration. (<i>See</i> Supply and services.)		
Command and staff relationships	3-3d	3-3	Impregnation of protective clothing. (<i>See</i> Supply and services.)		
Duties of the staff	3-4	3-3	Inspector general	2-11	2-4
Functions	3-3b	3-1	Installation support:		
Mission	3-3a	3-1	Concept of operation:		
Organization	3-3c	3-3	Director of installations section:		
Army exchange sales, (<i>See</i> Supply and services.)			Administrative services division ..	3-17a(1)	3-9
Automatic data processing	1-5c	1-2	Engineering and plans division	3-17a(2)	3-9
Automatic data processing unit:			Operations division ..	3-17a(3)	3-10
Assignment	2-16	2-5	Construction support:		
Mission	2-15	2-5	Construction support	3-17b(3)	3-10
Bakery services. (<i>See</i> Supply and services.)			Installation support	3-17b(2)	3-10
Band services	3-6c	3-5	The ENCOM	3-17b(1)	3-10
Bath. (<i>See</i> Supply and services.)			General:		
Chaplain services	3-6a	3-5	Engineer installation support	3-16a	3-9
Chemical and biological (CB) technical escort services. (<i>See</i> Supply and services.)			Mission and functions ...	3-16b	3-9
Civil affairs brigade:			Organization and capabilities ..	3-18	3-10
Command relationships	5-3	5-2			
Introduction	5-1	5-1			
Operational concepts	5-5	5-4			
Organization, missions, and functions	5-2	5-1			
Organizational concepts	5-4a-d	5-2			
CA company	5-4g	5-3			

	Paragraph	Page		Paragraph	Page
Labor service	3-6f	3-5	Property disposal. (See Supply and services.)		
Laundry. (See Supply and services.)			RAOC:		
Law and order	3-6e	3-5	General	3-27b	3-12
Local procurement. (See Supply and services.)			Organization	3-27c	3-12
Maintenance management detachment:			RAP:		
Mission	2-17	2-5	Command relationships	2-26	2-8
Operations	2-18	2-5	Functions	3-27a	3-12
Maintenance services:			General	2-25	2-8
Concept of operations	3-8	3-6	Renovation. (See Supply and services.)		
General	3-7	3-6	Service functions. (See Supply and services.)		
Organization and capabilities:			Signal operations company, medium headquarters:		
Headquarters and headquarters detachment, maintenance battalion	3-9b	3-7	Assignment	2-22	2-6
Maintenance battalion	3-9a	3-6	General	2-21	2-6
Maintenance company (DS) (COMMZ)	3-9c	3-7	Special services	3-6d	3-5
Transportation aircraft DS company	3-9d	3-7	Staff judge advocate	2-12	2-4
Medical service	1-5b(10), (11), 3-24	1-2, 3-11	Supply and services:		
Military intelligence company, counterintelligence	4-5, 4-6	4-3	Concept of operations:		
Military intelligence detachment, central records facility	4-3, 4-4	4-2, 4-3	Local procurement	3-14c	3-8
Military intelligence group, counterintelligence	4-1, 4-2	4-1	Property disposal	3-14d	3-8
Military intelligence support	3-25	3-11	Service functions	3-14b	3-8
Military police support:			Supply operations	3-14a	3-8
Area support command	6-1	6-1	Functions	3-13	3-8
Command and control	6-4	6-4	General	3-13	3-8
Military police, ASCOM HQ	6-5	6-5	Organization and capabilities:		
Military police battalion	6-3	6-3	Headquarters and headquarters company, and services.)		
Military police brigade	6-2	6-1	battalion	3-15a	3-9
Mission and function	3-19	3-10	Supply and service company	3-15b	3-9
Organization	3-20	3-10	Supply distribution. (See Supply and services.)		
Use of indigenous personnel	6-6	6-5	Supply operations. (See Supply and service		
Personnel and administration battalion:			Transportation services:		
Organization	2-19	2-6	Concept of operations:		
General	2-20	2-6	Car company	3-11a(1), 3-12a	3-7, 3-8
Personnel services	3-5, 3-6	3-5	Light-medium truck company	3-11a(1), 3-12b	3-7, 3-8
Petroleum, oil, and lubricants (POL) distribution. (See Supply and services.)			The transportation command (TRANSCOM)	3-11a(2)	3-7
Postal services	3-6b	3-5	General	3-10	3-7
			Organization and capabilities	3-12	3-8
			U.S. Army Security Agency (USASA)	1-6b	1-2

By Order of the Secretary of the Army:

W. C. WESTMORELAND,
General, United States Army,
Chief of Staff.

Official:

KENNETH G. WICKHAM,
Major General, United States Army,
The Adjutant General.

Distribution:

To be distributed in accordance with DA Form 12-11 requirements for the logistical Command.





.

.



.

.



3000017531



.

.

.



.

.



PENTAGON LIBRARY
300017531