

U
408.8
AI
FM 5-136

Reference

FM 5-136

DEPARTMENT OF THE ARMY FIELD MANUAL

Reference

SS July 66

ENGINEER BATTALION, AIRBORNE DIVISION



HEADQUARTERS, DEPARTMENT OF THE ARMY
NOVEMBER 1961

1. The first part of the document is a list of names and titles, including "The Hon. Mr. Justice G. D. C. O'Connell, Chief Justice of the Supreme Court of the State of New South Wales" and "The Hon. Mr. Justice G. D. C. O'Connell, Chief Justice of the Supreme Court of the State of New South Wales".

2. The second part of the document is a list of names and titles, including "The Hon. Mr. Justice G. D. C. O'Connell, Chief Justice of the Supreme Court of the State of New South Wales" and "The Hon. Mr. Justice G. D. C. O'Connell, Chief Justice of the Supreme Court of the State of New South Wales".

3. The third part of the document is a list of names and titles, including "The Hon. Mr. Justice G. D. C. O'Connell, Chief Justice of the Supreme Court of the State of New South Wales" and "The Hon. Mr. Justice G. D. C. O'Connell, Chief Justice of the Supreme Court of the State of New South Wales".

4. The fourth part of the document is a list of names and titles, including "The Hon. Mr. Justice G. D. C. O'Connell, Chief Justice of the Supreme Court of the State of New South Wales" and "The Hon. Mr. Justice G. D. C. O'Connell, Chief Justice of the Supreme Court of the State of New South Wales".

5. The fifth part of the document is a list of names and titles, including "The Hon. Mr. Justice G. D. C. O'Connell, Chief Justice of the Supreme Court of the State of New South Wales" and "The Hon. Mr. Justice G. D. C. O'Connell, Chief Justice of the Supreme Court of the State of New South Wales".

6. The sixth part of the document is a list of names and titles, including "The Hon. Mr. Justice G. D. C. O'Connell, Chief Justice of the Supreme Court of the State of New South Wales" and "The Hon. Mr. Justice G. D. C. O'Connell, Chief Justice of the Supreme Court of the State of New South Wales".

7. The seventh part of the document is a list of names and titles, including "The Hon. Mr. Justice G. D. C. O'Connell, Chief Justice of the Supreme Court of the State of New South Wales" and "The Hon. Mr. Justice G. D. C. O'Connell, Chief Justice of the Supreme Court of the State of New South Wales".

8. The eighth part of the document is a list of names and titles, including "The Hon. Mr. Justice G. D. C. O'Connell, Chief Justice of the Supreme Court of the State of New South Wales" and "The Hon. Mr. Justice G. D. C. O'Connell, Chief Justice of the Supreme Court of the State of New South Wales".

9. The ninth part of the document is a list of names and titles, including "The Hon. Mr. Justice G. D. C. O'Connell, Chief Justice of the Supreme Court of the State of New South Wales" and "The Hon. Mr. Justice G. D. C. O'Connell, Chief Justice of the Supreme Court of the State of New South Wales".

FIELD MANUAL }
 No. 5-136 }

HEADQUARTERS,
 DEPARTMENT OF THE ARMY
 WASHINGTON 25, D.C., 7 November 1961

ENGINEER BATTALION, AIRBORNE DIVISION

	Paragraphs	Page
CHAPTER 1. INTRODUCTION		
Section I. Basic information	1-3	3
II. Organization	4-9	4
CHAPTER 2. BATTALION HEAD- QUARTERS		
Section I. Mission and capabilities.....	10-12	7
II. Methods of operation.....	13-18	10
CHAPTER 3. ENGINEER COMPANY		
Section I. Mission and capabilities.....	19-23	19
II. Methods of operation.....	24-28	21
III. Company headquarters	29-35	23
IV. Engineer platoon	36-43	24
V. Squad	44-50	27
CHAPTER 4. HEADQUARTERS AND HEADQUARTERS COMPANY		
Section I. Mission and capabilities	51-57	30
II. Company headquarters	58-63	33
III. The staff sections.....	64-72	34
IV. Equipment platoon	73-81	37
CHAPTER 5. BATTALION OPERATIONS		
Section I. Basic considerations	82-84	42
II. Administrative movements	85-90	44

* This manual supersedes FM 5-136, 13 April 1959.

	Paragraphs	Page
Section III. Tactical movements	91-93	48
IV. Airborne operations	94-100	49
V. The advance to contact and the attack	101-106	59
VI. The defense	107-111	62
VII. Denial operations	112-115	66
VIII. River-crossing operations	116-118	68
IX. Special operations	119-123	69
X. Combat operations	124-126	73
APPENDIX I. REFERENCES		79
II. AIR-LANDING FACILITIES.....		83
INDEX		93

CHAPTER 1

INTRODUCTION

Section I. BASIC INFORMATION

1. Purpose

This manual provides information for commanders and staff officers on the operation and employment of the airborne division engineer battalion.

2. Scope

a. This manual outlines the organization, employment, missions, equipment, operations, and capabilities of the airborne division engineer battalion. This material is based on TOE 5-25, 5-26, and 5-27. Appendix II provides information on air-landing facilities. The material presented herein is applicable, without modification, to both nuclear and nonnuclear warfare.

b. Users of this manual are encouraged to submit recommended changes or comments to improve the manual. Comments should be keyed to the specific page, paragraph, and line of the text in which change is recommended. Reasons should be provided for each comment to insure understanding and complete evaluation. Comments should be forwarded direct to Commandant, U.S. Army Engineer School, Fort Belvoir, Va.

3. Mission

The primary mission of the airborne division engineer battalion is to increase the combat effectiveness

of the airborne division by combat support and general engineer work. The battalion may also undertake and carry out airborne infantry combat missions when required.

Section II. ORGANIZATION

4. Composition

The airborne division engineer battalion consists of a headquarters and headquarters company and three identical engineer companies (fig. 1).

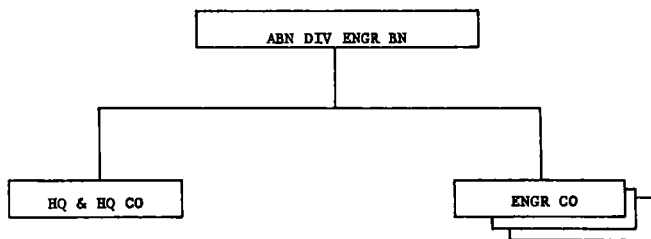

Figure 1. Organization chart, airborne division engineer battalion.

5. Major Items of Equipment

All items of equipment of the airborne division engineer battalion are listed in the applicable TOE's. All equipment is capable of being delivered by parachute or from landed C-130 and C-124 aircraft.

6. Mobility

The engineer battalion is 60 percent mobile in organic vehicles. Headquarters company and the headquarters platoons of the 3 engineers companies are 100 percent mobile. The operating squads of the companies are 30 percent mobile when equipped with the

light infantry weapons carrier (mule) authorized by the TOE. The mobility of the battalion is increased to 100 percent when 2½ ton dump trucks are authorized by the theater commander in lieu of the squad mule.

7. Assignment

The airborne division engineer battalion is organic to the airborne division, TOE 57.

8. Capabilities

Capabilities of the airborne division engineer battalion include—

- a. Engineer staff planning for the division.
- b. Supervision of organic and attached engineer troops.
- c. Construction, repair, and maintenance of roads, bridges, fords, and culverts.
- d. Support of stream-crossing operations and coordination of organic and supporting engineer troops in support of deliberate stream crossings.
- e. Bridging for passage of short gaps when necessary equipment is delivered to the battalion or otherwise obtainable.
- f. Assisting with removal and emplacement of obstacles, including mines and boobytraps.
- g. Preparing and executing demolitions, including employment of atomic demolition munitions (ADM).
- h. Performing engineer reconnaissance and intelligence missions.
- i. General construction, including construction of air-landing strips and helicopter landing sites.
- j. Providing personnel and equipment for purification and supply of water.

k. Assisting in the assault of fortified positions and assault demolitions of obstacles.

l. Technical assistance to other troops of the division in the construction of obstacles, fortifications, emplacements, camouflage, deception devices, and other engineer matters. Construct these facilities when required.

m. Engaging in airborne infantry combat-type missions when required.

n. Performing organizational maintenance repair service for equipment organic to the battalion.

o. Exploiting locally available sources of materials for construction, fortification, and camouflage.

9. Methods of Operation

a. One or more engineer companies may be attached or placed in direct support of an airborne infantry brigade for the airborne assault. The remaining companies are kept under battalion control. Companies attached to brigades revert to battalion control as soon as practicable after the assault, to insure maximum flexibility and economy of effort.

b. Items of construction equipment and operators, organic to headquarters and headquarters company are attached to the engineer companies as required.

c. Improvement of air-landing facilities in the objective area during the assault phase of airborne and airmobile operations is a responsibility of the battalion. When the capabilities of the battalion are exceeded, the battalion may be augmented by elements of the airborne light equipment company, or by other engineer units, as the situation requires.

d. The details of operational employment of the battalion are discussed in paragraph 82.

CHAPTER 2

BATTALION HEADQUARTERS

Section I. MISSION AND CAPABILITIES

10. Mission

The mission of battalion headquarters is to provide command, planning, and supervision for the battalion. In addition, it provides supply, medical, and administrative services for the battalion.

11. Organization

Battalion headquarters (fig. 2) is divided into the following elements: command, unit staff, unit special staff, and assistant division engineer section.

a. Battalion Commander. The battalion commander is also the division engineer and, as such, is a member of the division special staff. His command and staff functions are separate in that each involves different responsibilities and duties. The battalion commander's duties consist of implementing the engineer battalion capabilities listed in paragraph 8 and those shown in FM 5-1. His duties as division engineer are outlined in FM 5-1 and FM 101-5. In addition, if the use of nuclear weapons is contemplated, the engineer:

- (1) Participates in a preliminary conference with interested members of the division staff to determine the best method of carrying out the division commander's plan. He may be called on to present reasons for the retention or elimination of specific targets.

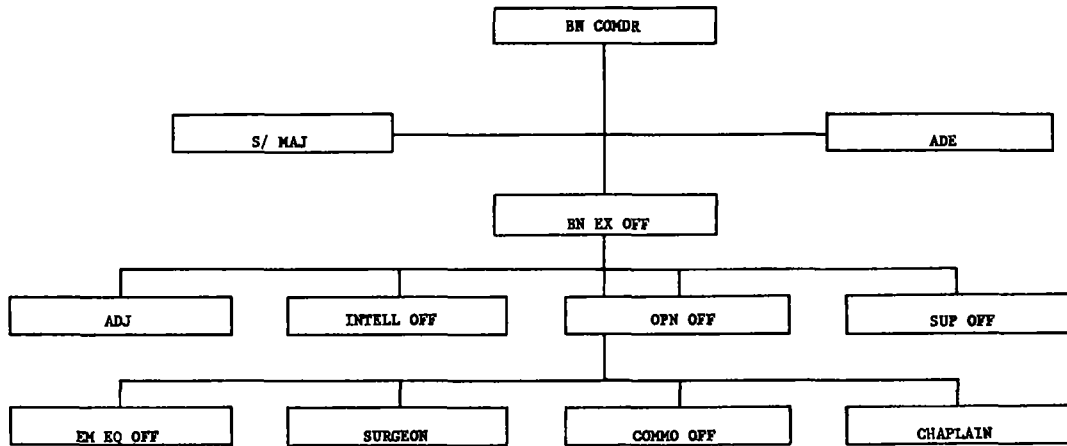

Figure 2. Battalion headquarters.

- (2) When the use of atomic demolition munitions (ADM) is contemplated and during the general planning, the division engineer is responsible for assisting in or performing ADM target analysis and making recommendations as to DGZ, type of munitions, yield and height or depth of burst. When the decision is made to employ an ADM, the division engineer is responsible for the preparation of the ADM plan as part of the division operations order. He is also responsible for designation of the emplacement unit and the movement of equipment, material, and personnel to support an ADM mission.

b. Staff. The duties of the commander and staff officer personnel are as shown in FM 101-5 and FM 5-135. The main duties of the various staff sections are briefly explained in section III of chapter 4, Headquarters and Headquarters Company.

12. Capabilities

The airborne division engineer battalion headquarters is capable of:

a. Planning and supervising engineer operations in the airborne division, including requirements for attached troops.

b. Performing engineer reconnaissance and intelligence functions.

c. Supplying water to the airborne division and attached troops.

d. Providing unit-level medical service, to include medical care for the battalion, establishing aid stations, and furnishing aid men to battalion units.

e. Technical assistance and advice to accomplish organizational maintenance.

f. Operating as an infantry battalion headquarters when required.

Section II. METHODS OF OPERATION

13. Training

a. Battalion headquarters conducts on-the-job training for staff personnel with particular emphasis on the following:

(1) Parachute operations.

(2) Air-landed operations.

(3) Construction of fixed wing and helicopter landing facilities.

b. Battalion headquarters supervises training throughout the battalion with emphasis as shown in *a* above. Training is conducted as prescribed in appropriate ATP's, FM's, TM's, and other training publications.

c. Battalion headquarters provides assistance in training other units within the airborne division in combat engineering subjects.

14. Maintenance

The battalion is responsible for first and second echelon maintenance of organic equipment. Higher echelon maintenance is performed by the division support command.

15. Administration

Internal administrative requirements are handled in accordance with current directives in the routine manner. Personnel actions will be processed to the

division administration company through the battalion personnel staff NCO in accordance with the division personnel and administration SOP.

16. Methods of Employment

Battalion headquarters is employed in the same manner as in other divisional engineer battalions, except during an airborne assault. Establishment of the assault command post is covered in paragraph 97. The operational employment of the battalion is covered in paragraph 82.

17. Supply

a. Responsibility. The battalion commander is responsible for the supply of the battalion and for the supply of water to the division.

b. Procedures.

- (1) *Ground operations.* Normal supply procedures are followed in the airborne division engineer battalion, except in the first stages of an airborne assault (FM 57-10).
- (2) *Airborne assault.* The quantity and types of engineer supplies and equipment to be brought into the airhead are limited by the number and types of aircraft to be used. There will seldom be sufficient airlift to bring in all the desired engineer items. Therefore, maximum use must be made of supplies and equipment locally available. The intelligence effort is specifically directed toward development of sources of supply in the objective area. Some considerations in delivery of supplies and equipment for engineer use in an airborne operation are —

- (a) Prepackaging of barrier and construction materials.
- (b) Delivery of materials direct to job sites or to landing zone nearest using unit (fig. 3).
- (c) Use of Army aviation when available, particularly helicopters, for delivery from drop or landing zone to job site.
- (d) Use, in the airborne assault, of individual parachutists for delivery of mines, wire on bobbins, demolitions, or other materials and small equipment necessary to accomplish the mission.

c. Water Supply. The variable nature of an airborne operation requires that water supply equipment (fig. 4) be capable of very rapid displacement and that alternate water points be selected prior to the operation. The equipment may be delivered to the water point by parachute or any available prime mover capable of pulling the trailer. Water supply procedures are as set forth in TM 5-295.

d. Class IV and V Supplies. Certain class IV and V supplies, such as field fortification materials, when delivered by parachute or air-landed, should be in prepackaged composite loads capable of delivery to work sites, either directly, or by helicopter, or by vehicle, from the drop zone or air-landing facility. An example of a prepackaged composite load of field fortification materials is a load consisting of all mines, pickets, and wire (or bobbins if required) for a 75-yard length of standard minefield. Except for assault supplies, packaging and preparation for delivery of non-TOE supplies is the responsibility of the division support command.



Figure 3. Delivery of construction equipment and fuel on the construction site.

18. Communications

a. *The Assault Net.* An assault radio net (fig. 5) is used until vehicular-mounted radios become operational in the airhead. The normal battalion radio net (fig. 6) may be used during air-landed operations by careful planning to coordinate the arrival of individuals with their command vehicles. Parachute delivery

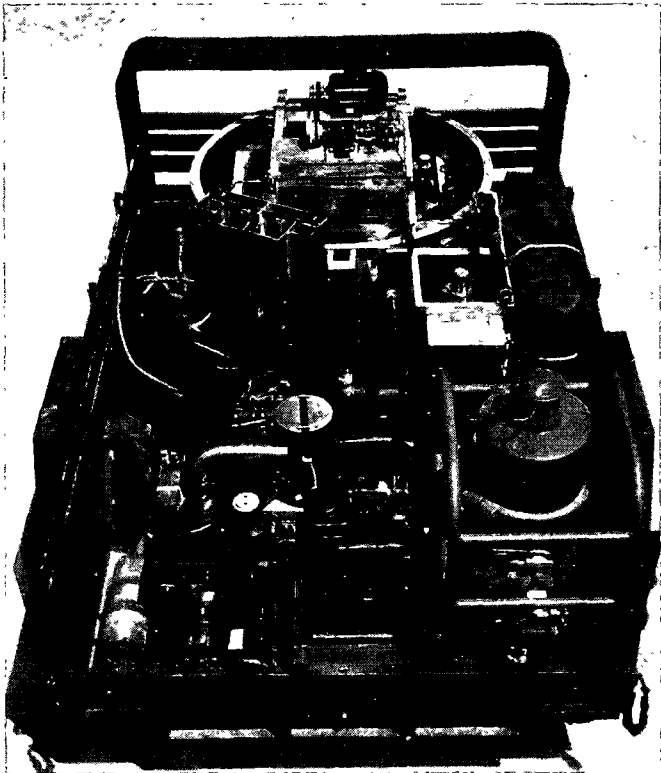

Figure 4. Continuous-flow water purification set.

in the airhead may require that commanders carry the AN/PRC-10, with one individual in battalion headquarters (communications officer) responsible for parachuting with or near a radio suitable for entering the division command net. The assault radio net may then appear as in figure 5.

b. Subsequent Operations. Following arrival of vehicular-mounted radios in an airhead and during ground combat, planned radio and wire nets are established and maintained as shown in figures 6 and 7, which depict typical radio net organizations.

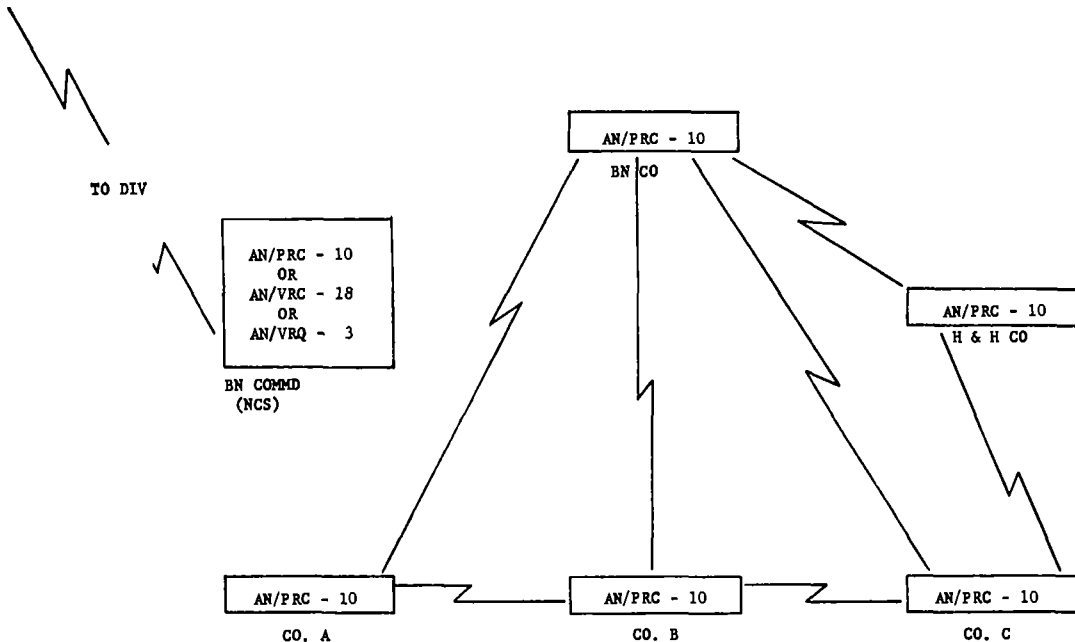

Figure 5. Typical assault radio net.

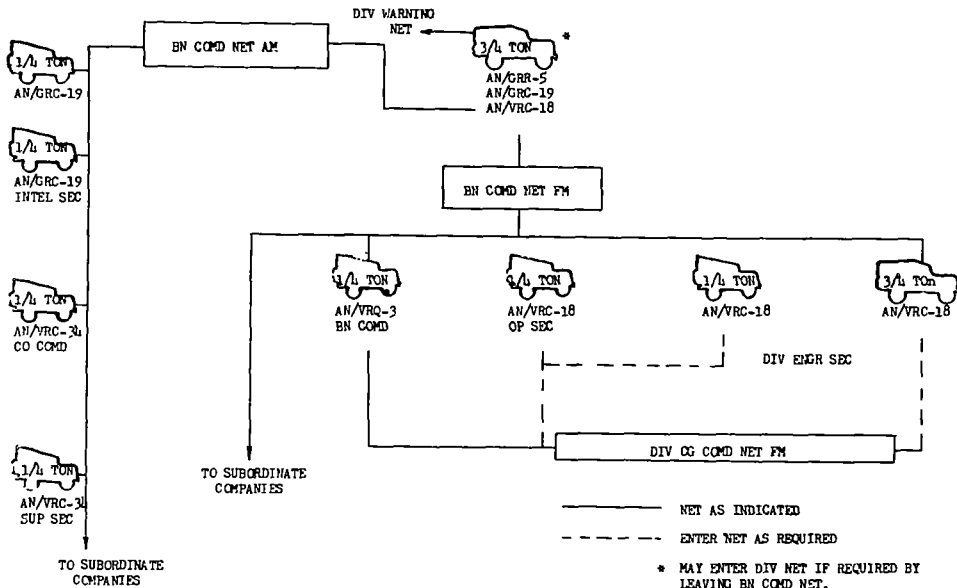

Figure 6. Typical radio net, airborne division engineer battalion.

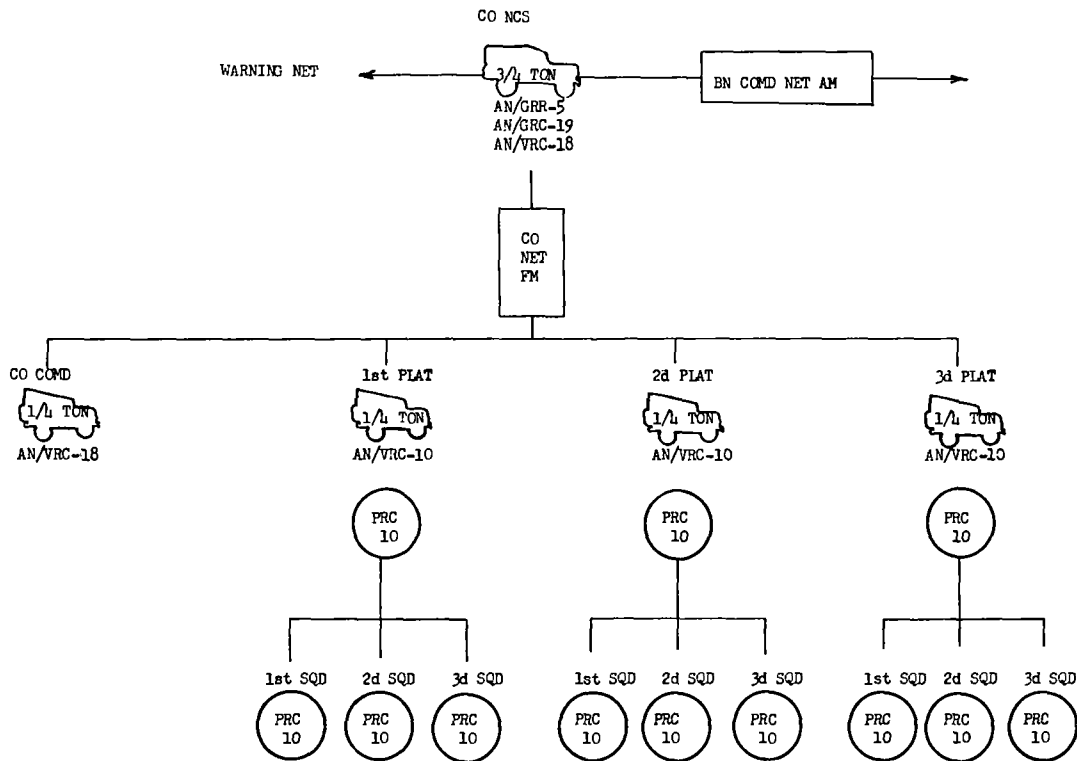

Figure 7. Typical radio net, engineer company and platoon.

CHAPTER 3

ENGINEER COMPANY

Section I. MISSION AND CAPABILITIES

19. Mission

The primary mission of the engineer company, airborne division engineer battalion, is to provide an operating component of the airborne division engineer battalion.

20. Organization

The company is organized into a company headquarters and three identical airborne engineer platoons (fig. 8) at full strength. One engineer platoon is deleted at reduced strength.

21. Mobility

The company is approximately 50 percent mobile with organic transportation and 100 percent air-transportable in C-130 and C-124 aircraft.

22. Assignment

Three identical companies are organic to the airborne division engineer battalion.

23. Capabilities

The company at full strength is capable of—

a. Supervision of organic and attached engineer troops.

b. Construction, repair, and maintenance of roads, bridges, fords, and culverts.

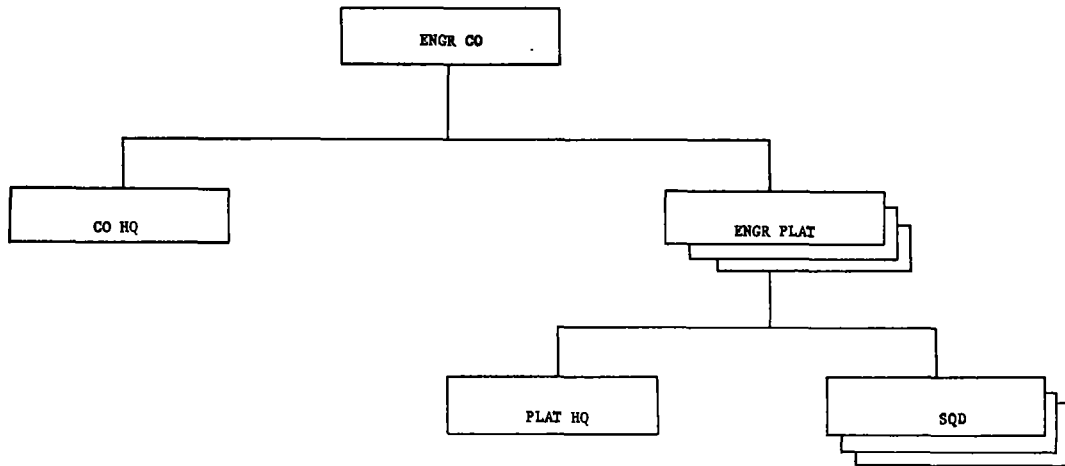

Figure 8. Organization chart, engineer company.

c. Assisting in the removal of obstacles, including mines and boobytraps.

d. Preparing and executing demolitions, including atomic demolition munitions (ADM).

e. Performing engineer reconnaissance and intelligence missions.

f. General construction, including construction of fixed wing and helicopter landing facilities.

g. Assisting in the assault of fortified positions and assault demolitions of obstacles.

h. Technical assistance to supported troops in construction of obstacles, fortifications, emplacements, camouflage, deception devices, and other engineer matters. May construct these facilities when required.

i. Engaging in airborne infantry combat missions when required.

Section II. METHODS OF OPERATION

24. Maintenance

The assigned drivers, equipment operators, and radio operators perform first echelon maintenance on their equipment. The maintenance section and the radio mechanic of company headquarters, assisted by battalion maintenance personnel, perform organizational inspections, maintenance, and repair on organic equipment.

25. Training

The engineer company is responsible for the training of its personnel in accordance with training policies of battalion headquarters. It assists other units of the division by providing technical assistance for these units in engineer subjects.

26. Administration

Responsibility for administration in the engineer company is normally delegated to the company executive officer. Assisted by the first sergeant, he coordinates and supervises the efforts of the mess, supply, and motor sergeants to accomplish the total administrative requirement.

27. Supply

Supply functions in the engineer company are accomplished by the company supply sergeant under the supervision of the executive officer. On-the-job training in basic supply procedures is given by company supply personnel to the platoon tool room helpers.

28. Employment

a. Airborne Assault. Usually companies are attached to airborne infantry brigades during the airborne assault. The same engineer company normally operates with the same infantry brigade, whether attached or in direct support, or whether in training or in combat. Companies not attached to brigades are assigned pre-planned engineer tasks and are delivered into an air-head as close to the objective job site as is practical.

b. Centralized Control. For the purpose of economy of effort and more effective control, company attachments to airborne infantry brigades cease as soon as the tactical situation permits. The companies then revert to battalion control. Normally, an engineer company is not attached or placed in direct support of a reserve brigade but performs general engineer works in support of the division until the reserve is committed.

Section III. COMPANY HEADQUARTERS

29. Mission

The mission of the company headquarters is to provide command, administration, supply, and equipment support for the platoons of the company.

30. Organization

The company headquarters is organized and equipped to provide continuous command and administrative support for the engineer platoons of the company.

31. Equipment

The company headquarters commits items of heavy equipment to support the mission of the platoon which has the greatest need. The company headquarters supervises and controls equipment attached from the battalion equipment platoon or equipment attached to the company by the battalion from a supporting unit (airborne equipment company).

32. Mobility

The company headquarters is 100 percent mobile in organic transportation and 100 percent air-transportable in C-130 and C-124 aircraft.

33. Training

The company headquarters supervises and supports all training conducted within the company. Necessary cross training is accomplished by on-the-job training. Specialists are trained at the appropriate service school.

34. Administration

Administration for the entire company is accomplished in the company headquarters. The engineer platoons are relieved, so far as possible, of all administrative responsibilities to allow them to train or perform their assigned missions.

35. Employment and Operations

In an airborne assault, the company headquarters establishes a command post. (See figure 7 for typical company communications net.) Companies attached or in direct support of brigades undertake missions in support of the brigade as soon as possible. Other companies undertake general support missions under the control of the engineer battalion.

Section IV. ENGINEER PLATOON

36. Mission

The mission of the platoon is to perform combat engineer missions. The platoon is the operating component of the engineer company, airborne division engineer battalion.

37. Organization

The platoon consists of a platoon headquarters and three identical squads (fig. 8).

38. Equipment

The major items of equipment in the platoon are; the four wheel tractor with attachments, a dump truck, the electric tool kit, the $\frac{1}{4}$ ton 4 x 4, and platoon carpenter and pioneer hand tool sets. The platoon leader,

assisted by the platoon sergeant, supervises and controls the equipment operators to insure maximum utilization and production. A typical equipment task is illustrated in figure 9.



Figure 9. Electric pioneer tool set used by airborne engineer platoon.

39. Mobility

The platoon is approximately 40 percent mobile in organic transportation when squads are equipped with the light infantry weapons carrier and 100 percent mobile when squads are equipped with the 2½ ton truck.

40. Assignment

Three identical engineer platoons are organic to the engineer company.

41. Capabilities

When properly equipped the engineer platoon is capable of—

a. Providing personnel for assistance in engineer planning when attached to the airborne infantry battalion, including that required for supporting troops.

b. Performing construction and repair work on roads, bridges, fords, and culverts.

c. Assisting in the construction and repair of command posts, shelters, and defensive installations.

d. Providing an air-landing facility suitable for assault aircraft when augmented by equipment and equipment operators.

e. Preparing and executing demolitions to include atomic demolition munitions.

f. Providing technical assistance to supported units.

g. Constructing or breaching obstacles.

h. Conducting engineer reconnaissance and providing essential items of engineer information.

42. Training

The engineer platoon conducts training for its personnel and assists in engineer training of personnel from other units in the airborne division. Additionally, each platoon conducts adequate cross training of all personnel to assure depth of trained personnel in all aspects of platoon operations.

43. Employment

a. As the operating component of the engineer company, the platoon executes missions and tasks assigned by the company commander. The platoon may be at-

tached to a battalion or battalion task force for specific missions of short duration. Attachment should terminate as soon as the situation permits to insure maximum utilization and economy of effort.

b. The platoon is trained to accomplish missions of the type listed in paragraph 41. Issue of special tools, equipment, and supplies is necessary before the platoon may undertake heavy construction, ADM or bridge missions requiring prefabricated bridging.

c. Figure 7 shows a typical platoon communications net.

Section V. SQUAD

44. Mission

The mission of the engineer squad is to perform those combat engineer tasks assigned by the platoon headquarters.

45. Organization

The squad is the basic working unit. The duties of the personnel in the squad are as outlined in AR 611-201.

46. Equipment

The major items of equipment in the squad are the squad carpenter and pioneer hand tool sets, the chain saw, the squad demolitions set and light infantry weapons carrier (mule). The squad may be issued a dump truck in lieu of the mule when authorized by the theater commander. Figure 10 depicts parachute delivery of squad equipment.

47. Mobility

The squad is approximately 30 percent mobile in organic transportation and 100 percent air-transportable in assault aircraft or in cargo helicopters. Mobility is increased to 100 percent when the 2½ ton dump truck is issued in lieu of the light infantry weapons carrier.

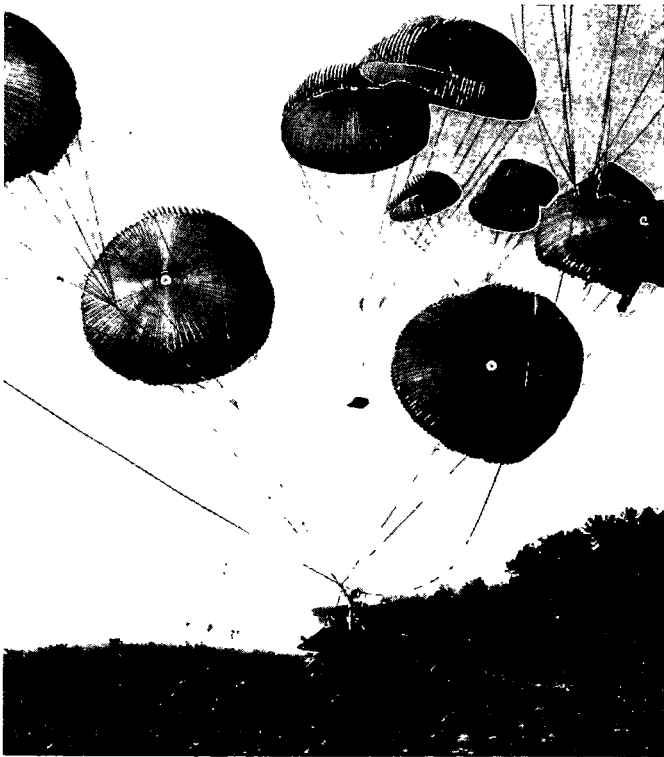

Figure 10. Squad truck and equipment pallet arriving in the drop zone.

48. Assignment

Three squads are organic to the engineer platoon.

49. Capabilities

The squad is capable of providing personnel, equipment, and technical knowledge for accomplishing tasks assigned by the platoon headquarters.

50. Employment

The squad functions as a part of the platoon. Occasionally, when attached to a small task force or where platoon job sites are widely dispersed, the squad may be given a separate engineer mission. It may be assigned an independent mission such as support of an infantry company in a helicopter-borne raid. Assignment of this type of mission requires attachment to the supported unit. The squad is most effective when employed as a part of the platoon where a maximum of control can be maintained.

CHAPTER 4

HEADQUARTERS AND HEADQUARTERS COMPANY

Section I. MISSION AND CAPABILITIES

51. Mission

The mission of headquarters and headquarters company is —

a. To provide engineer special staff assistance to the division, and command and staff, communications, reconnaissance, administration, supply and heavy equipment for the airborne division engineer battalion.

b. To undertake and carry out airborne infantry combat missions of a headquarters and headquarters company when required.

52. Organizational

Headquarters and headquarters company (fig. 11) consists of the company officers and the enlisted personnel who work in battalion headquarters, company headquarters, and in the operating sections and the equipment platoon. The organization and functions of the battalion headquarters are explained in chapter 2.

53. Equipment

Items of equipment are listed in the applicable TOE. Headquarters and headquarters company provides engineer construction equipment to the companies of the airborne division engineer battalion.

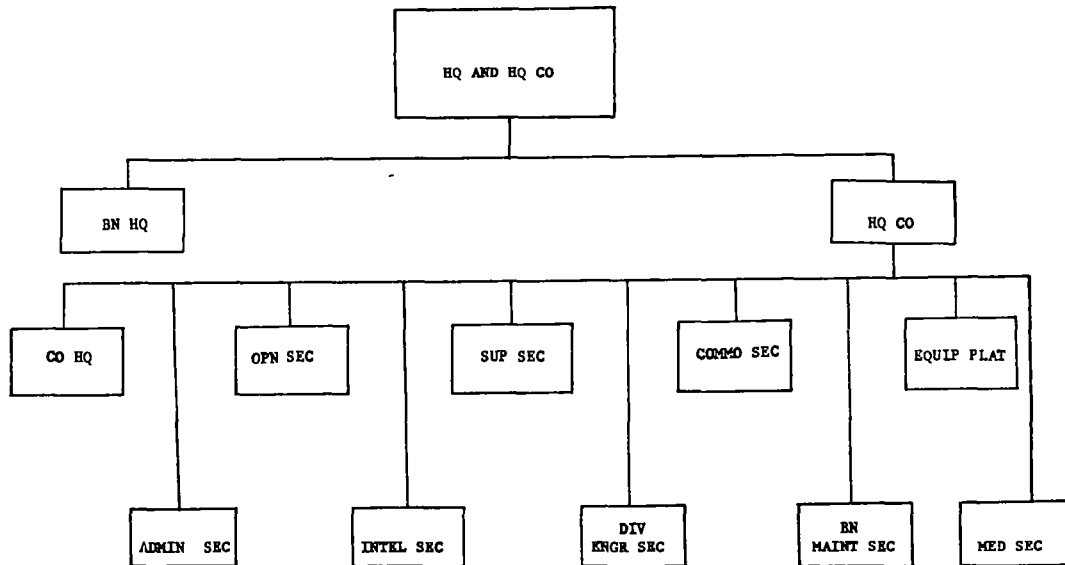

Figure 11. Headquarters and headquarters company.

54. Mobility

Headquarters and headquarters company is 100 per cent mobile with organic transportation and 100 per cent air-transportable in C-130 and C-124 type cargo aircraft.

55. Assignment

A headquarters and headquarters company is organic to the airborne division engineer battalion.

56. Capabilities

Headquarters and headquarters company is capable of—

a. Providing personnel and necessary assistance for battalion headquarters to perform those tasks outlined in paragraph 11.

b. Providing engineer construction equipment to the companies of the battalion.

c. Providing minimum security for the battalion headquarters command post.

d. Carrying out airborne infantry combat missions of a headquarters and headquarters company.

57. Employment

The company feeds, clothes, supplies, quarters, and handles the administration for all personnel in battalion headquarters and in its own operating platoon and sections. The section chiefs and the company commander informally arrange their working schedules to permit the battalion headquarters personnel to participate in military training activities, administrative housekeeping details, or security of the bivouac area.

a. *Airborne Assault.* Elements of headquarters and headquarters company will usually be attached to the

engineer companies and will accompany these supported units in the assault. Examples of attachment are engineer construction equipment, and operators, surveyors, medical aid men, and reconnaissance teams. The remainder of headquarters and headquarters company normally accompanies the battalion headquarters into the airhead and assists in establishing a command post, communications, and security.

b. Subsequent Operations. Upon completion of specific tasks, those elements of headquarters and headquarters company attached to other units are returned to company control, or diverted to other engineer tasks conducted by another unit.

Section II. COMPANY HEADQUARTERS

58. Mission

Company headquarters provides administrative services for the personnel of headquarters and headquarters company. These services pertain, in a broad sense, to all of the requirements of the personnel including mess, supply, quarters, and other miscellaneous requirements.

59. Organization

Company headquarters is organized under the appropriate TOE to perform command and administration functions required in accomplishing its mission.

60. Equipment

Items of equipment for company headquarters are listed in the appropriate TOE. It consists essentially of weapons to accomplish the security mission and

administrative and cargo vehicles to accomplish the support mission of the company.

61. Mobility

Company headquarters is 100 percent mobile with organic transportation and 100 percent air-transportable in C-130 and C-124 type cargo aircraft.

62. Training

Company headquarters plans, conducts, and supervises training of all personnel assigned to the company and to battalion headquarters except for certain specialized MOS training which is supervised by the appropriate staff section of battalion headquarters.

63. Administration

Company headquarters performs administrative services for personnel assigned to headquarters and headquarters company and to the battalion headquarters.

Section III. THE STAFF SECTIONS

64. Introduction

Headquarters and headquarters company is composed of the officers and enlisted men who work in the battalion headquarters sections, company headquarters, and the equipment platoon. The functions of the various staff sections are briefly explained in this section. The operation of each staff section is the responsibility of the appropriate staff officer. The battalion executive officer is normally responsible for directing, coordinating, and supervising the battalion staff. A

detailed explanation of the function of the combat engineer battalion staff may be found in FM 5-135.

65. Administrative Section

This section is responsible for all administration performed in the battalion including correspondence and mail delivery. The section is supervised by the battalion S1. It is also responsible for the education functions of the battalion.

66. Intelligence Section

The intelligence section coordinates and supervises engineer intelligence activities of the battalion. Information is processed, evaluated, and disseminated as the total engineer intelligence of the division sector. It is prepared for use by the general and special staffs of division headquarters and for dissemination to major subordinate commands as well as organic engineer companies. The intelligence section coordinates its activities closely with the division G2 and the battalion operations section. It may be called on to provide technical advice pertaining to map coverage and allocation. The reconnaissance teams perform the field engineer reconnaissance mission which is a directed effort concerned with the operation of the division. The section is under the supervision of the S2.

67. Operations Section

This section is charged with the staff functions that relate to training and operation of the battalion. It directs and coordinates the efforts of subordinate elements and supporting units to accomplish the combat support and general support missions assigned by the

division. It prepares operations orders and engineer task directives for the elements of the battalion to implement the commander's concept or verbal instructions. It is the focal point of liaison activities and contains a chemical subsection to supervise, train, and advise the battalion on CBR matters. The section is under the supervision of the S3.

68. Supply Section

The supply section plans and coordinates requirements for engineer maintenance and supply activities in the battalion and maintains close liaison with the division support command. The S4 is assisted by a supply warrant officer who supervises the battalion supply section. The water supply subsection operates four water points which furnish water to the division. The activities of battalion maintenance are closely associated with and operate within the staff supervision of the S4. In addition, the section supervises and inspects food service activities within the battalion and advises the battalion commander and subordinate units on matters pertaining to engineer supply and food service.

69. Division Engineer Section

This element forms the engineer special staff section at division headquarters. The division engineer section is organized to operate at two echelons or two command posts when established. The section is concerned with staff planning for future operations. The division engineer section is under the direct supervision of the assistant division engineer who is the commander's engineer advisor at division forward (main).

70. Communications Section

The communications section is responsible for operation of telephones and radio communications for the battalion, and may be responsible for operation of a message center for the battalion. The section plans and coordinates communications within the battalion and operates the battalion headquarters' radio, wire, and teletype communications facilities. It provides technical assistance to subordinate units on matters pertaining to communications. The section also provides organizational maintenance for organic radios and conducts communications training within the battalion for operations and maintenance personnel.

71. Battalion Maintenance Section

The maintenance section performs the organizational maintenance (second echelon) for headquarters company and backs up and supports the organizational maintenance of the company maintenance sections. The maintenance section is concerned primarily with ordnance and engineer vehicular items of equipment.

72. Medical Section

The section furnishes medical services for the battalion. Medical aid men are attached to the companies as needed. The section operates a battalion aid station and dispensary. It is supervised by a general medical officer who also is the battalion surgeon.

Section IV. EQUIPMENT PLATOON

73. Mission

The mission of the equipment platoon is to support the engineer companies with engineer construction equipment and operators.

74. Organization

The equipment platoon is organized by the applicable TOE with personnel and equipment to perform the mission described above.

75. Equipment

The equipment organic to the platoon consists essentially of: crawler and wheeled dozers, motorized road graders, airborne craneshovels, and an air compressor. All of this equipment may be delivered by parachute or in C-124 cargo type aircraft (figs. 12 and 13).

76. Mobility

The equipment platoon is 100 percent mobile with organic transportation and completely air-transportable in C-130 and C-124 cargo type aircraft.

77. Assignment

An equipment platoon is organic to headquarters and headquarters company of the airborne division engineer battalion.

78. Capabilities

The equipment platoon is capable of—

a. Providing engineer construction equipment and operators for the engineer companies.

b. Providing technical assistance to the supported unit in the use and capabilities of the equipment.

c. Providing assistance to headquarters and headquarters company in planning and directing the employment of platoon equipment.

d. Supervising the movement of platoon equipment to and from the job sites.

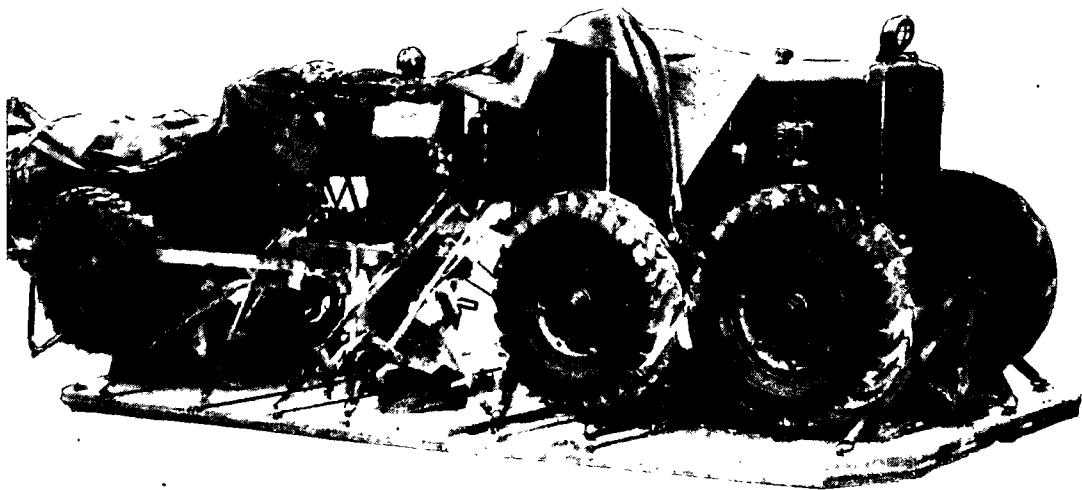

Figure 12. Motorized grader rigged for parachute delivery.

e. Accomplishing construction missions which require equipment work only.

79. Maintenance

The equipment platoon performs operator maintenance on organic equipment. The maintenance section of headquarters and headquarters company performs organizational inspections and maintenance of the

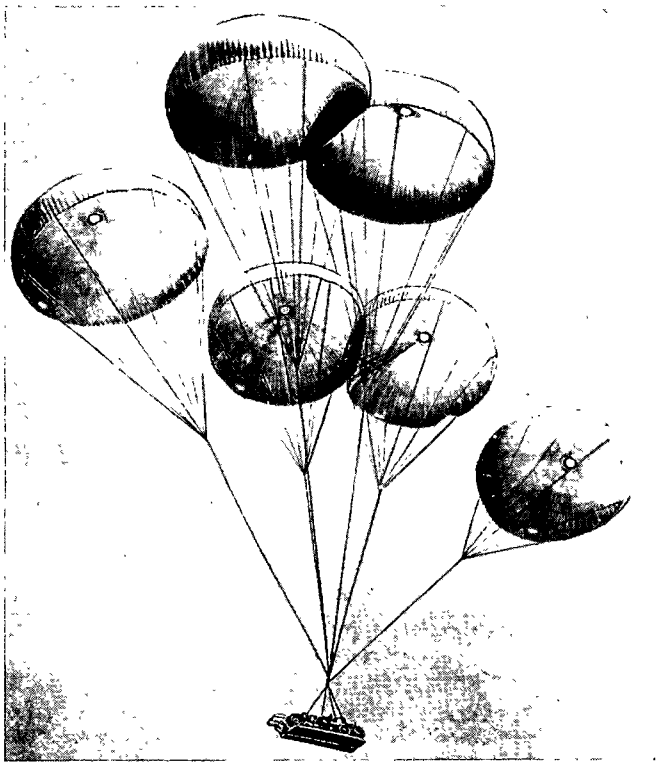

Figure 13. Parachute delivery of a motorized road grader.

equipment. Higher echelon maintenance is performed by the airborne division support command.

80. Training

a. Unit training of equipment platoon personnel is conducted by the platoon leader and supervised by the headquarters and headquarters company commander.

b. Specialist training of equipment operators and supervisors is given by on-the-job training, a unit school supervised by the equipment platoon leader, or an army service school.

81. Employment

Separate pieces of equipment, with operators, are allocated by the battalion commander for specific purposes on the recommendations of the S3, and upon completion of the project are returned to the equipment platoon for inspection and reassignment. The unit commander using the equipment has operational control over it, and is responsible for proper use of the equipment and for the supervision, rations, and quarters of the operators. Under certain conditions the equipment platoon may be assigned missions of the type which involve primarily the use of earth moving equipment, such as construction of an air landing facility.

CHAPTER 5

BATTALION OPERATIONS

Section I. BASIC CONSIDERATIONS

82. Employment

a. The airborne engineer battalion is a self-contained unit designed to provide engineer combat support in the airhead or forward portion of the battle area. It has the ability to overcome a variety of obstacles incident to the movement of the division, and hence contributes to the mobility of the division and its capability to maneuver in offensive action. In defense, retrograde, or denial operations, it has the capability to materially impede the progress of enemy ground operations by blocking critical avenues of approach of enemy ground combat vehicles.

b. The airborne engineer battalion operates as part of division troops and deploys its companies in support of the brigades and combat elements of the division. The headquarters company contains engineer construction equipment and operators to appropriately supplement the engineer companies for specific tasks.

c. Airborne engineer companies are normally associated with particular brigades to increase operational efficiency. The company performs the unit engineer functions of tactical engineer staff planning and execution of the engineer missions in this role. Continuous liaison is maintained by the company to the brigade for this purpose.

d. Attached or supporting engineers should be kept

under brigade control when possible. Platoons are placed in support of battalions or task forces for specific missions.

e. Attachment of engineer teams to combat elements is necessary for accomplishment of specific tasks requiring close command control. In the offensive this may consist of assault breaching or demolition tasks. In defense or retrograde the execution of barrier demolitions and the employment of ADM may require mission type attachment.

f. Airborne engineer troops engage in limited combat incident to accomplishment of their normal missions. Disengagement of engineer elements is made by other combat elements so as to continue engineer missions. When the situation requires deliberate commitment of the engineer battalion in an infantry mission, it will be done with division command authority and with unit integrity preserved.

g. When task organizations are committed on separate missions, an appropriate engineer element is provided by the engineer battalion to accompany the force.

h. When the requirement for engineer support within the division exceeds the capability of the division engineer battalion, additional engineer support must be provided by the next higher echelon of command.

- (1) The additional engineer support to the division may range from reinforcing the combat engineer strength to the provision of such support as bridging, road and airfield construction, debris removal, erection of barriers, mapping, survey, camouflage, and deception.
- (2) Nondivisional engineer units are normally placed in support of the division. However,

engineer units are attached when their missions necessitate close command control in execution. Hasty river-crossing missions, barrier demolition tasks, or use of ADM are examples of such situations. All engineer combat support provided to the division is coordinated by the division engineer.

83. Standing Operating Procedure

An SOP is prepared for the battalion and all operating elements (FM 101-5).

84. Security

Each commander is responsible for the security of his unit. Security includes all measures taken by a commander to protect his unit against enemy interference, surprise, and observation. The measures adopted should be appropriate to the threat. As the threat increases, greater security measures are required to protect troops and equipment in bivouac and during movement and to protect work parties. Work parties are sometimes protected by infantry elements, so more engineer troops can be released for work on engineer missions. Details of composition, organization, operation, and nomenclature of security elements are given in FM 7-20 and FM 7-21.

Section II. ADMINISTRATIVE MOVEMENTS

85. Engineer Assistance to Other Arms

a. Type of Work. The division usually needs engineer support when it moves administratively. A move may be by motor, rail, water, or air. During move-

ments, engineer work generally consists of the following:

- (1) Providing facilities and assistance during loading and unloading of divisional elements at point of departure and at destination.
- (2) Maintaining roads and bridges.
- (3) Preparing the new area to receive the unit. This involves providing or improving facilities.

b. Employment. Engineer assistance normally requires keeping some engineers at the point of departure until the bulk of the division has moved; providing an engineer advance party to prepare the new area; and sending some engineers with each major echelon moving independently. During administrative movements, engineers normally remain under control of the battalion commander. In general, engineer assistance is limited to work of benefit to the division as a whole or to work for which engineers are better trained and equipped than other troops. Supported units provide their own facilities and labor as far as practicable.

86. Engineer Work at Departure Point

a. Type of Work. Engineers at departure points may—

- (1) Construct or strengthen ramps and loading platforms.
- (2) Construct or improve routes of approach.
- (3) Construct or improve preloading assembly areas.

- (4) Provide technical assistance to troops of other arms to load and lash equipment.

b. Loading Facilities. Every effort is made to choose departure points that require only a minimum of new construction and improvement. However, loading ramps and platforms often have to be built. In many cases, the engineer battalion will work in close coordination with the airborne division support command in this phase of a division administrative movement.

87. Engineer Work on Roads

a. Engineer Reconnaissance. Engineers make a detailed route reconnaissance before a major motor march. The engineer must be able to provide the following information:

- (1) Load capacities of roads and bridges, and vertical road clearance.
- (2) Estimate of time and effort necessary to put required routes in condition to support division loads.

b. Engineer Work. Engineer work consists of strengthening bridges and repairing roads prior to movement of the division.

88. Engineer Work at Destination

Troops should be able to move their organic and attached transportation off the road and into their bivouac areas without halting. To make this possible, engineers may have to construct temporary crossings over roadside ditches and gullies, improve secondary roads and trails, and clear new trails. Engineer work at the destination is similar to that at the departure

point. Other engineer tasks at the destination include area improvement, assisting in the construction of CP's and shelters, repair of existing facilities, water supply, and construction or repair of roads and bridges within the division area.

89. Traffic Circulation

a. The airborne division engineer battalion assists in the preparation of division traffic circulation plans. This assistance, however, applies generally to all moves and not to administrative moves only. Assistance is provided by—

(1) Conducting road and bridge reconnaissance.

(2) Making recommendations based on the load carrying capacity of the road net and the availability of engineer troops to maintain the road net.

(3) Preparing and posting road signs and markers.

b. Division staff responsibility for traffic control rests with the division G4.

90. Battalion Movement

a. *Introduction.* During administrative movements the airborne division engineer battalion, less those units assigned support tasks, usually moves as a unit forming an integral part of the division. For all movements the battalion loads its own equipment.

b. *Movement Tables.* Properly prepared movement tables provide the unit with a known system of moving by any mode of transportation. The movement tables are prepared for motor, rail, water, or air movement and are based on pertinent technical data contained in military publications pertaining to each individual piece of equipment and data in FM 101-10, TM 57-210,

SB 5-110, and FM 5-35. In the airborne division engineer battalion, emphasis is placed on movement by air, and the battalion must have complete and current movement data available at all times. In addition to transportation by use of cargo aircraft, the use of Army helicopters should be anticipated for transporting elements of the engineer companies. Air-movement tables should be prepared as outlined in TM 57-210 and FM 57-10. When possible, key personnel should be distributed throughout the lift to minimize the effect of losses.

c. Training. Prior to departure, troops are instructed in the loading and lashing of equipment, safety regulations applicable to mode of transportation, and plans for unloading and reassembly at the destination.

Section III. TACTICAL MOVEMENTS

91. Introduction

The airborne division normally makes tactical movements by foot, motor, or air. The mission of the unit, proximity to hostile forces, terrain, types of enemy resistance expected, and activity of hostile air forces are all primary factors that will determine the organization and composition of the column in a tactical movement. All units should have movement tables prepared as a part of their SOP's.

92. Motor Movement

During a tactical motor movement the airborne division engineer battalion may move in one trip by use of organic transportation. Detailed loading plans should be prepared in advance for each vehicle of the battalion.

93. Battalion Movement

The airborne division engineer battalion participating in an airborne division tactical movement will normally furnish a company to support each of the leading brigades. The remainder of the battalion moves as directed by the division commander. In some tactical air movements, the battalion will be responsible for providing air-landing facilities at the destination (app. II).

Section IV. AIRBORNE OPERATIONS

94. Introduction

a. The airborne division engineer battalion is a specialized unit capable of entry into a combat area by either air-landed or parachute means. The battalion is designed to perform combat engineer tasks in an assault role in support of an airborne division. The battalion is 60 percent mobile with organic equipment and is only slightly less capable of performing construction missions than the normal infantry division engineer battalion. The length of time that the battalion can sustain itself is contingent upon the logistical support provided, the weather, the terrain, the enemy situation, and the extent of engineer effort required for the operation.

b. The division engineer recommends disposition of available engineer troops (fig. 14) for all phases of the airborne operation based on the scheme of maneuver as announced by the division commander. The division engineer recommends appropriate changes in disposition as the situation develops and the need arises.

c. If the division engineer determines that the engi-

neer tasks required exceed the capabilities of the battalion, he immediately provides the division commander with information as to the minimum additional engineer forces needed to accomplish the mission. The division commander may request reinforcement. In this case, additional units are placed in support of or attached to the battalion.

d. Because of the intermingling of friendly and enemy forces during the early stages of an airborne assault, the airborne division engineer battalion may be required to engage in limited ground combat operations for sustained periods more often than engineers in other combat situations. Limitations on the strength of maneuver of units in the objective area may further

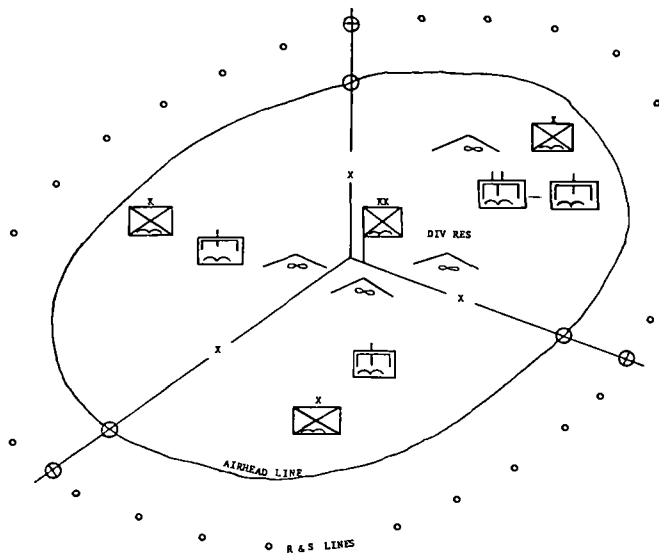

Figure 14. Typical initial disposition of engineer battalion in an airborne operation.

require frequent commitment of the engineer battallion as a fighting reserve. Preparation and training for an airborne assault should emphasize these requirements.

95. Planning

In planning for an airborne operation, in addition to the orders and plans issued to the battalion, the division engineer is responsible to the division commander for certain elements of the division plan and concept of operation.

a. *Terrain Intelligence.* The Battalion S2 will assist the Division Engineer in planning and preparation of terrain studies and site analysis to support division operations. Support may normally be obtained from an Engineer Detachment (Terrain) and/or Engineer Intelligence staffs at Army or Theater level. An engineer detachment (Terrain) is occasionally assigned to Corps, and may be attached to an Airborne Division to prepare terrain intelligence for any anticipated operation.

(1) A Tactical Commanders Terrain Analysis (TACCTA), designed for airborne operations or other terrain analysis, may be prepared for distribution to all major tactical commanders as designated by the G2. These will include data on the following:

- (a) Landing zones, drop zones, and airfields.
- (b) Roads, bridges, fords, ferries, and culverts.
- (c) Weather and climate
- (d) Cross country movement conditions, including data on rivers and streams.
- (e) Water supply.

- (f) Obstacles and fortifications.
- (g) Tactical considerations including cover, concealment, observation, fields of fire, key terrain, and avenues of approach.
- (h) Construction material.

(2) Special engineering site plans should be prepared by the battalion commander and staff.

b. The Selection of Landing Zones and Air-Landing Facilities. The selection and location of adequate and usable landing zones and air-landing facilities may have a vital effect on the tactical plan (app. II). The commander of the unit furnishing the aircraft is responsible for final selection of air-landing facilities.

c. The Engineer Plan of Operation. The success of the engineer portion of an airborne operation is dependent upon well coordinated missions and proper disposition of available engineer troops and equipment. The division air movement table must be reviewed by the engineer to insure coordinated movement of the engineer battalion into the airhead.

d. Water Supply. Units participating in the assault should carry with them the maximum possible amounts of water in individual canteens and unit water containers. The amount of time necessary to make the waterpoints operational can be minimized by careful study of maps and aerial photographs and by delivery of water-supply equipment as close as possible to the selected sites.

e. Division Operations Order. Besides making the above recommendations to the division commander and his staff, the engineer is also responsible for preparing the following annexes to the division operations order,

based on the division commander's concept of operation:

- (1) *Barrier annex.* For the unit engineer's responsibilities for barrier planning and for drafting the barrier annex, refer to FM 31-10.
- (2) *Engineer annex.*

96. Preparation

After orders have been issued to the engineer battalion, the companies which will be attached to committed brigades usually join those brigades in specified marshalling areas and prepare for the operation with the supported unit. The remainder of the battalion is usually marshalled in a designated area, maintained and administered by supporting units, and briefed in sufficient time to allow rigging of equipment and movement of personnel and equipment to the departure airfields. FM 57-10 outlines the detailed steps of preparation for an airborne assault.

97. Airborne Assault

a. Air Movement. The engineer battalion accompanies the airborne division into the airhead area and is delivered in accordance with the division air-movement table by means of parachute or air-landing in C-130 or C-124 cargo type aircraft.

b. Reorganization. Immediately upon arrival in a landing zone or drop zone, the battalion reorganizes in specified assembly areas and establishes an assault command post with an assault radio net. Upon assembly the battalion moves to a preselected bivouac area and establishes its command post.

c. *Communications.* Communications in the airborne division engineer battalion are discussed in paragraph 18.

d. *Command Posts.*

- (1) *Organization.* As soon as possible after the initial airborne assault, the battalion and its companies move into preselected areas and establish operational command posts (fig. 15) and communications nets. The organization of a command post is the responsibility of the unit commander. It is accomplished in a manner which best suits the needs of the unit and is based on the capabilities of the headquarters itself.
- (2) *Alternate command posts.* Active nuclear warfare requires the establishment of alternate command posts to assure continuous operation. The division engineer may design-

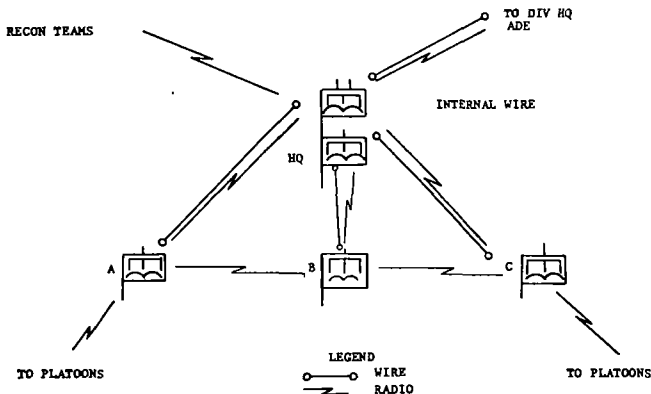

Figure 15. Typical organization of communications from command posts.

nate the liaison officer of the assistant division engineer section as the nucleus of an engineer staff section at the alternate division command post. The limited number of personnel assigned to the airborne division engineer battalion headquarters may preclude the establishment of an alternate command post. A less efficient but feasible solution is to designate the physical location of an alternate battalion command post. This location serves as a rallying point for survivors and permits rapid reconstitution of the battalion headquarters following a nuclear attack. The unit SOP should provide as much guidance as possible on this subject.

e. Engineer Effort. Immediately upon assembly in the drop zone or landing zone, those engineer units with preassigned tasks normally move directly from the landing area to their work sites. Engineer reconnaissance is initiated immediately and is continued throughout the operation. Close coordination with airborne infantry elements must be maintained to assure that the areas of engineer work have been secured by the infantry.

f. Supplies and Equipment. Where the coordinated air movement plan allows delivery of supplies and equipment directly on the work site, the engineers' problems have been reduced to a large extent. The original plan must provide for delivery of engineer supplies and equipment on the landing zone or drop zone nearest the work site. Upon delivery, the supplies and equipment are collected by the engineer troops and

either moved to the work site or centrally located for ready access by the using unit.

98. Subsequent Operations

After complete reorganization and communications have been established, initial supplies delivered and recovered, and initial engineer projects are started, the engineer battalion enters into a normal engineer support role for the airborne division. Additional missions are assigned to the battalion by the division commander, and are then assigned as projects to the subordinate units of the battalion. The major engineer effort is directed toward improvement of air-landing facilities, roads and bridges, and toward execution of a complete and coordinated barrier plan. Attached engineer companies revert to battalion control as soon as possible, but may remain in direct or general support of the brigades or may be assigned specific engineer tasks by the engineer battalion, as the tactical situation dictates.

99. Exploitation

a. After the division airhead line is established, the assault may be exploited by the division by one or more of the following:

- (1) Improving the area for development as an advance air base, naval base, port, storage area, or missile site, and providing for its security.
- (2) Launching large-scale ground operations from the area.
- (3) Seizing or denying the enemy use of critical terrain, road and rail nets, waterways, sig-

nal communications facilities, and natural resources, and protecting potential allies.

- (4) Destruction or capture of enemy forces, missile sites, and airfields.
- (5) Seizing terrain or other objectives inaccessible to other types of ground troops.
- (6) The capture and utilization of manufacturing areas, resources, or governmental control facilities and agencies as directed.

b. The exploitation missions are normally determined during the planning stages of an airborne operation, and the engineer support required for them is planned accordingly. It may be necessary to have additional engineer support introduced into the airhead to augment the airborne division engineer battalion. Typical engineer support units are the airborne engineer light equipment company delivered by parachute or air-landed means, and engineer bridge company, or elements of a combat engineer battalion (Army) delivered by air-landed means.

c. Other exploitation operations which may require engineer support are raids against targets of opportunity, blocking enemy reinforcement or withdrawal, reinforcing other units which have been operating independently, advancing successively to secure critical areas ahead of or to the flanks of friendly armored or other mobile forces, and blocking or counterattacking enemy penetrations of other ground forces. These operations can be performed by employing normal ground transportation, Air Force or Army transport aircraft, or by parachute operations from the established airhead. Engineer support for those operations may be in direct support or by attachment to the in-

fantry elements conducting the operation. The ability of the airborne division to conduct operations from the objective area will depend upon—

- (1) The enemy situation.
- (2) The division's own capability with particular emphasis on the buildup of supplies and personnel which can be introduced into the air-head.
- (3) The number and status of air-landing facilities. The construction or improvement of air-landing facilities is a determining factor, and the engineer battalion may require additional support from other engineer units, particularly the airborne engineer light equipment company. Advanced elements from this company may accompany the engineer battalion in the initial airborne assault with additional personnel and equipment delivered as a planned portion of the air movement of engineer troops and equipment for the division.

100. Withdrawal by Air

Withdrawal from an objective area may be forced by the enemy or may be made voluntarily. Advanced planning is imperative as the nature of the area of operations and the limitations of transport aircraft introduce complicating factors not present in other ground actions. Supplies and materials which cannot be evacuated are destroyed. The engineer battalion supports the airborne division in this type of operation by—

a. Executing certain obstacles, i.e., bridge demolitions, or atomic demolition munitions, to prevent

enemy advance which would cause delay or interfere with the withdrawal.

b. Preparing or maintaining air-landing facilities to accommodate the necessary aircraft for the withdrawal.

c. Providing adequate road nets and bridging for the units moving to the departure facilities.

d. Assisting in destruction of equipment not capable of being withdrawn.

e. Engaging in limited ground combat operations.

Section V. THE ADVANCE TO CONTACT AND THE ATTACK

101. Introduction

When the infantry units move from the drop or landing zones to their initial objectives or to the prescribed airhead line positions, the advance to contact and the attack are initiated. The division engineer recommends disposition of available engineer troops and equipment for all phases of the advance and attack, based on the division commander's scheme of maneuver. Engineers may be used to support flank and other security forces as well as attacking elements.

102. Engineer Missions

a. During the advance to contact and the attack, emphasis is placed on off-the-road parking facilities, bivouacs, and camouflage. Reconnaissance is detailed and continuous, and is conducted, in part, by all commanders concerned.

b. In general, the engineer mission is to assist the

forward movement of attacking echelons. The mission may be considered threefold:

- (1) Assisting the movement of infantry and supporting arms by clearance of minefields, obstacles, and fortifications.
- (2) Assisting the troops protecting the flanks by creating obstacles in roads and other possible avenues of approach to the flanks.
- (3) Performing general engineer tasks.

103. Control of Engineer Effort

a. Disposition of Engineer Troops. The recommended disposition of engineer troops is normally made by assigning engineers specific tasks, placing engineer units in support of other elements, or, in some cases, by attachment.

b. Responsibility for Control. The division engineer maintains contact with supporting and attached elements to assure that maximum value is obtained from the engineer effort expended. The engineer unit commander retains control and command of the engineer element, but must suit his plans and troop employment to the plans of the supported unit or units.

c. Liaison.

- (1) Liaison between supporting and supported units must be maintained during the attack to assure cooperation and coordination between all units participating in the operation.
- (2) The assistant division engineer is the chief liaison agent between the airborne engineer battalion and division headquarters. Similarly, liaison functions between the supporting engineer companies and the brigades are

performed by the company commander or agent designated by the company commander (executive officer).

104. Engineer Duties in the Attack

Typical engineer duties in the attack include—

- a.* Conducting reconnaissance.
- b.* Assisting in preparation of traffic circulation plans.
- c.* Assisting forward movement of infantry and supporting arms by repairing roads, constructing expedient bridges, and removing obstacles.
- d.* Assisting in locating, marking, and removing mines.
- e.* Assisting in flank security through the use of demolitions (including ADM's), minefields, and obstacles.
- f.* Constructing pioneer or hasty Army airfields for divisional aircraft.
- g.* Improving air-landing facilities for assault type cargo aircraft.
- h.* Performing other duties such as the procurement and distribution of water. These are continuous and normal duties of headquarters and headquarters company.

105. Engineer Reconnaissance

a. Engineer reconnaissance during the advance is performed initially by the reconnaissance teams from battalion headquarters and by reconnaissance elements from the engineer units supporting the infantry. These teams provide the division and the brigades with early,

reliable engineer information concerning the terrain over which the unit is to advance.

b. Engineer reconnaissance during the advance should include—

- (1) Serviceability and types of roads.
- (2) Location of critical points.
- (3) Alternate routes.
- (4) Mines.
- (5) Bridges and river-crossing sites.
- (6) Locally available construction equipment and materials.
- (7) Water supply sources.
- (8) Estimates of engineer effort required.
- (9) Recommended traffic circulation.
- (10) Obstacles.

106. Pioneer Work Done by Other Arms

Because there are seldom enough engineer troops available to do all the pioneer work necessary to assist the advance of the infantry and supporting arms, the other troops do as much of this work as possible in order to help themselves. All combat and service troops are trained in the installation and removal of mines. Infantry troops do much of their own pioneer work, assisted by technicians from the supporting engineer companies.

Section VI. THE DEFENSE

107. Introduction

a. After assault objectives have been seized in an airborne operation, the airborne force normally passes to the defensive. The period of time involved will vary

depending upon the mission assigned to the airborne division, the size and composition of the force, enemy reaction, and the type operation contemplated.

b. Defense of the airhead may consist of a variation of the area defense, or a delaying action may be employed under certain circumstances. The defense envisions organizing and occupying strongpoints on dominant terrain along the airhead line to cover main routes of approach into the airhead; covering unoccupied terrain between defended localities by fire, mines, and other artificial and natural obstacles; continuous reconnaissance and surveillance intensified during the hours of darkness; withholding a reserve and establishing priorities for designation of new or additional reserves. Enemy attacks are countered by shifting units and boundaries, reinforcing threatened areas, employing fire support means, and by counterattacking. The shape of the airhead affords the airborne division interior lines of communication, facilitating shifting of troops and commitment of reserves. Reserves are held in positions of readiness prepared to counterattack, to occupy defense positions, or to execute blocking missions. Positions are prepared in depth within the capabilities of the airborne unit. The airhead defensive line must provide adequate space for maneuver, for protection of critical installations, and for air-landing or air-evaluation operations (FM 57-10).

108. Engineer Functions in the Defense

Defensive positions are usually laid out and constructed by the troops which are to occupy them. Engineers may be used to prepare alternate or supplementary positions and to perform such duties as—

a. Repairing, maintaining, and improving roads for supply and evacuation, and recommending traffic circulation plans.

b. Assisting in implementation of the barrier plan.

c. Assisting in the construction of command posts, observation posts, and obstacles of all types.

d. Providing engineer intelligence.

e. Providing technical assistance in camouflage to include verification of effectiveness by aerial observation.

f. Engaging in limited ground combat.

g. Improving and maintaining air-landing facilities.

h. Constructing or improving and maintaining pioneer or hasty Army aviation airfields.

i. Conducting reconnaissance.

j. Water supply.

109. Barrier Plan

The division engineer assists in preparing and implementing the barrier plan for the defense of the airhead. Maximum use of locally available materials, natural and artificial, may be required for constructing obstacles. The use of atomic demolitions munitions assists in creating additional obstacles. Antitank mines are used extensively in likely routes of armored approach.

110. Defense Against Nuclear Attack

a. Normal active and passive defensive measures are employed with emphasis on individual protective measures. Particular stress is placed on the importance of deep foxholes and the provision of overhead cover.

The engineer battalion conducts the following tasks in defensive planning for nuclear attack:

(1) *For the division.*

- (a) Surveys area for suitable shelters and assists in planning and constructing protective facilities for key installations.
- (b) Selects alternate water point sites.
- (c) Selects and prepares an alternate bridge site for each bridge required.

(2) *For the battalion.*

- (a) Disperses unit personnel, equipment, and supplies consistent with operational practicability.
- (b) Organizes unit first aid, rescue, and evacuation teams.
- (c) Prepares a CBR defense SOP based on that of the division.

b. In the event of an actual nuclear detonation, the airborne division engineer battalion accomplishes the following:

(1) *For the division.*

- (a) Decontamination of essential areas or clearing of exit routes required for evacuation to safe areas.
- (b) Construction and posting of signs for unsafe areas.
- (c) Firefighting missions.
- (d) Clearance of debris from essential routes and air-landing facilities.
- (e) Production of maximum amount of potable water.
- (f) Such other engineer tasks as are required.

(2) *For the battalion.*

(a) First aid, rescue, and evacuation.

(b) Preparation of personnel and equipment decontamination stations.

111. Defense Against Airborne Attack, Guerrilla Action, and Infiltration

The airborne division engineer battalion must establish, within its area of operation, an observation and warning system and local security which are adequate for defense against enemy airborne, guerrilla, and infiltration tactics. The battalion may be called upon to construct obstacles for the airborne division which would act as a deterrent to the use of such enemy tactics.

Section VII. DENIAL OPERATIONS

112. Introduction

As in barrier planning, the airborne division engineer has staff responsibility for denial planning and supervision. Denial targets of local tactical significance should be incorporated in the division barrier plan, within the policies of higher commanders.

113. Uses of Denial Operations

In an airborne operation, denial operations may be used to deny an area of facility to the enemy to—

a. Isolate areas chosen for further operations from the airhead.

b. Prevent the reinforcement or resupply of the enemy.

c. Limit or restrict enemy maneuvers.

- d.* Protect the airhead in the defense.
- e.* Impede enemy attack.
- f.* Deny further use of an occupied airhead area if the airborne element is withdrawn.
- g.* Restrict movement of refugees into the occupied airhead area.

114. Implementation

Engineer commanders at all levels of command in the airborne division give advice and furnish technical supervision for the supported units, and they execute demolition tasks as assigned. Extensive use is made of the engineer equipment and demolitions in the removal or destruction of items to be denied to the enemy. Troops of other arms and services are also used extensively in denial operations.

115. Use of Atomic Demolition Munitions

a. ADM's may be used for denial operations. Normally the officer responsible for the execution of a mission requiring the installation and firing of an ADM will be the commander of the engineer emplacement and firing unit. He ordinarily directs all operations at the emplacement site, takes emergency action in the event of a change of mission or misfire, and detonates the ADM in accordance with the demolition order.

b. Engineer personnel prepare the emplacement site under the direction of the engineer emplacement site commander. This may include providing appropriate access roads, installing antitank and antipersonnel mines or other obstacles, camouflaging the area to avoid disclosure of the operation, providing local security, and providing communication facilities. En-

gineer personnel install the ADM in the emplacement and complete all preparation of the site. They are responsible for firing the ADM or recovering it if the mission is cancelled or otherwise changed.

Section VIII. RIVER-CROSSING OPERATIONS

116. Introduction

a. The airborne division, or elements of the division, may conduct river-crossing operations when suitably equipped, as follows:

- (1) During the initial establishment of the airhead.
- (2) While conducting link-up with friendly forces.
- (3) While conducting aggressive reconnaissance from the objective area.
- (4) As a portion of a raid from the objective area.
- (3) While expanding the airhead as a means of providing more space for maneuver and for additional air-landed elements.

b. River lines and the possible requirement for river crossings during the early stages of an airborne assault are to be carefully considered when the objective area and the airhead line are selected during the planning phase. Wide rivers provide excellent natural obstacles as a part of the airhead line, but may require river-crossing operations by the airborne elements in further situations.

117. Capabilities

The airborne division engineer battalion has no organic river-crossing equipment. Personnel of the battalion have the technical training to construct and

emplace standard military floating and fixed bridges. Expedient construction may be practical under certain conditions for hasty crossings of short gaps. Deliberate crossings of wide rivers must be supported by corps or army engineer troops as explained in FM 31-60.

118. Conduct of River-Crossing Operations

a. Hasty crossings of unfordable streams and small rivers located in the division area may be accomplished by the airborne engineer battalion provided the bridging is delivered to the constructing unit or otherwise available.

b. Deliberate river-crossings of large streams must be supported by additional troops and equipment. The airborne division engineer companies cross with the airborne brigades to provide support on the far shore. Corps or Army engineer troops furnish the necessary equipment and construction crews to accomplish the bridging mission and all near shore support. The conduct of river-crossing operations is explained in detail in FM 31-60.

Section IX. SPECIAL OPERATIONS

119. Armor-Arborne Link-Up

a. Armored forces are frequently employed in effecting a surface link-up with an airhead.

b. The airborne division engineer must assure adequate roads, bridges, and clearance of obstacles for the passage of armored vehicles into or through the airborne division airhead. If engineer effort is required beyond the periphery of the division area, elements of the airborne division engineer battalion may be re-

quired to move out of the airhead. This can be accomplished by surface transportation or airlift with assault aircraft or helicopters (fig. 16). Such an operation may require infantry support for security of the work sites. The engineers may also be required to assist in flank protection for the armored units while they operate in the division area. This flank protection may include construction of barriers or denial operations. The use of prepositioned atomic demolition munitions in this type of an operation is a likely mission, and continuous engineer planning in this direction must be effected.

120. Amphibious Operations

a. The airborne division is not ideally suited for participation in an amphibious assault in an amphibious role without augmentation of additional engineer equipment and personnel.

b. The airborne division may be associated with amphibious assault elements in the same manner as with armored forces during the link-up of airborne forces with friendly surface elements. The engineer considerations for this type of operation generally parallel those for a link-up with an armored force.

c. The conduct of an amphibious operation is outlined in FM's 60-5 and 60-30.

121. Desert Operations

Successful operations in the desert will require special individual and unit equipment to augment the airborne division engineer battalion TOE. Additional water points and an increase in the amount of low ground pressure construction equipment will normally



Figure 16. Engineer reconnaissance team being airlifted in an armor-airborne link-up operation.

be required. Extensive open areas and long range visibility may make it difficult to achieve surprise, thereby reducing the time available for assembly and initial organization.

122. Arctic Operations

If committed in arctic operations, the airborne division engineer battalion may require augmentation of engineer construction equipment and special vehicles. The requirements for summer and winter are quite different, i.e., during winter, frozen lakes may provide suitable landing facilities while in summer, construction of such facilities in tundra may require prohibitive engineer effort. Any augmentation of equipment or personnel is based on the necessities of the specific situation.

123. Mountain and Jungle Operations

In such operations the airborne division engineer battalion operates as in normal airborne operations. If extensive clearance work is required for air-landing facilities, the battalion may require augmentation by equipment and operators.

Section X. COMBAT OPERATIONS

124. Introduction

The airborne division engineer battalion or any element thereof engages in combat operations when—

- a. The enemy prevents access to the unit's job site.
- b. The enemy attempts to drive the engineer unit from a job site.
- c. The enemy prevents delivery of supplies.

d. Enemy action forces sustained ground combat. This may develop in several ways:

- (1) The unit commander is forced into a sustained ground combat role to save the unit.
- (2) Enemy action forces the unit to fight in order that the higher command might accomplish its mission.
- (3) The major commander has no alternative other than to commit the engineer unit because of a desperate situation.

125. Sustained Combat

In the event there is a necessity to employ the engineer battalion or elements thereof in a sustained combat role, the unit must be prepared to accept this mission with a minimum of delay. Engineer units are to be committed as a unit and not as separate parts of a unit. This allows the commander to preserve unit integrity.

a. *Responsibility.* The major force commander is responsible for the decision to commit engineer units to a sustained ground combat role. He should commit the engineer unit only after careful consideration of the restrictions imposed by the loss of engineer support.

b. *Situations for Committing Engineer Units in a Sustained Ground Combat Role.* There are many situations where the major force commander may commit an engineer unit to this role. Some of the more typical situations are—

- (1) An overextended defensive front.
- (2) A sudden enemy penetration or turning movement.

- (3) An enemy airdrop or an organized guerrilla activity in a rear area.

c. *Type of Mission.* The type of mission that an engineer unit will receive in a combat role is to be limited by its weapons and personnel. Primarily, there are two types of roles. These are *attack* and *defense*.

- (1) *Attack type mission.* This type of mission is usually limited to situations which require engineer units to engage bypassed enemy elements in order to get to critical job sites.
- (2) *Defense type mission.* The defense type mission is the one most commonly assigned to airborne engineer units. The major combat force commander should allow enough time for the engineer unit to prepare for this type of mission, so that the proper type of support can be coordinated and the nonessential personnel and items of equipment can be moved to an area where they will not be captured or destroyed by the enemy force. When ample warning time is available to the engineer commander, he prepares his unit for combat in the same way as any other combat force commander.

126. Guides for the Committed Engineer Unit Commander

A definite plan must be established which will enable the unit to move efficiently from the normal engineer support type role to a combat type role. This plan, part of the unit's SOP, should be established for each individual unit. The basic parts of the plan are—

a. Purpose. The purpose of the plan to include the sustained ground combat mission which could be assigned to the engineer unit.

b. References. The references to be used as pertained to the basic infantry concept of operations for the type missions indicated above.

- (1) Appropriate sections of pertinent field manuals and other publications.
- (2) FM 7-11, Rifle Company, Infantry, Airborne Infantry, and Mechanized Infantry Battalions.
- (3) FM 7-15, Infantry, Airborne Infantry, and Mechanized Infantry Rifle Platoons and Squads.
- (4) FM 7-20, Infantry, Airborne Infantry, and Mechanized Infantry Battalions.

c. Procedures. The procedures to be followed when the order is given for the engineer unit to prepare for sustained ground combat. This section will designate the components of the forward and rear echelons of the command.

- (1) *The forward echelon.* The forward echelon will consist of enough sections and units to accomplish the mission. Elements should include—
 - (a) Firepower and maneuvering elements—to find, fix, and destroy or eject the enemy.
 - (b) Communications element—to establish communications between all echelons of the command (fig. 17).
 - (c) Supply element—to provide the necessary supplies for the mission.

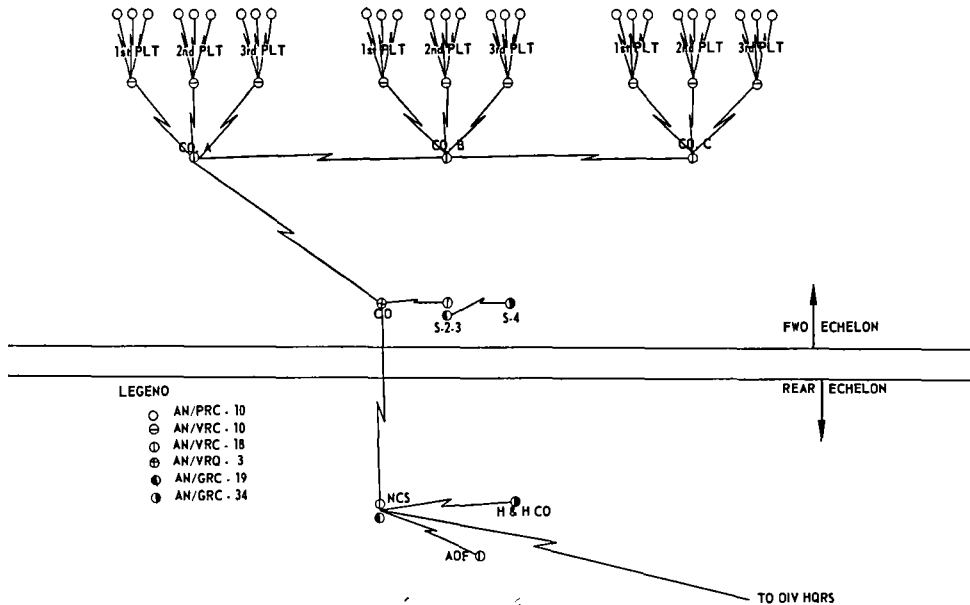

Figure 17. Typical radio net of airborne engineer battalion in sustained combat operation.

- (d) Command element—to direct the elements in the accomplishment of their mission. The control of firepower is established at the command level to enable the commander to effectively employ the combined firepower to influence the action at any time or from any direction.
- (2) *The rear echelon.* The rear echelon will include all of the equipment not directly essential to the sustained ground combat mission. Such items as nonessential vehicles and heavy equipment are to move to a rear area designated by the commander. The responsibility for the control of the rear area is to be designated in this section of the SOP.

d. Coordination. This section establishes a guide for coordination between other units of the command, including adjacent combat units and fire support units.

APPENDIX I

REFERENCES

1. The DA Pamphlets listed below should be consulted frequently for current listing of applicable publications and for current information on changes and revisions.

- 108-1 Index of Army Motion Pictures, Filmstrips, Slides, and Phono-Recordings.
- 310-1 Military Publications: Index of Administrative Publications.
- 310-3 Military Publications: Index of Training Publications.
- 310-4 Military Publications: Index of Technical Manuals, Technical Bulletins, Supply Bulletins, Lubrication Orders, and Modification Work Orders.
- 310-5 Military Publications: Index of Graphic Training Aids and Devices.

2. The publications listed below will be of particular value to the airborne engineer battalion or its organic units.

a. Army Regulations and Special Regulations.

- AR 350-1 Army Training Policies.
- AR 380-5 Safeguarding Defense Information.
- AR 611-201 Manual of Enlisted Occupational Specialties.
- AR 611-101 Manual of Commissioned Officers Military Occupational Specialties.

b. Field Manuals.

- 5-1 Engineer Troop Organizations and Operations.
- 5-15 Field Fortifications.
- 5-20 Camouflage, Basic Principles, and Field Camouflage.
- 5-22 Camouflage Materials.
- 5-23 Field Decoy Installations.
- 5-25 Explosives and Demolitions.
- 5-31 Use and Installation of Boobytraps.
- 5-34 Engineer Field Data.
- 5-35 Engineers' Reference and Logistical Data.
- 5-36 Route Reconnaissance and Classification.
- 5-132 Infantry Division, Engineers.
- 5-134 Armored Division Engineer Battalion.
- 7-11 Rifle Company, Infantry, Airborne Infantry, and Mechanized Infantry Battalions.
- 7-19 Combat Support Company, Infantry Division, Battle Group.
- 7-20 Infantry, Airborne Infantry, and Mechanized Infantry Battalions.
- 7-21 Headquarters and Headquarters Company, Infantry Division Battle Group.
- 20-32 Land Mine Warfare.
- 21-5 Military Training.
- 21-6 Techniques of Military Instruction.
- 21-26 Map Reading.
- 21-30 Military Symbols.
- 21-31 Topographic Symbols.
- 21-40 Small Unit Procedures in Nuclear, Biological, and Chemical Warfare.

- 21-41 Soldier's Handbook for Nuclear, Bio-
logical, and Chemical Warfare.
- 27-10 The Law of Land Warfare.
- 30-5 Combat Intelligence.
- 30-16 Technical Intelligence.
- 30-19 Order of Battle Intelligence.
- 31-10 Barriers and Denial Operations.
- 31-15 Operations Against Irregular Forces.
- 31-21 Guerrilla Warfare and Special Forces
Operations.
- 31-50 Combat in Fortified Areas and Towns.
- 31-60 River Crossing Operations.
- 31-71 Northern Operations.
- 41-10 Civil Affairs/Military Government Oper-
ations.
- 54-2 Division Logistics and Support Com-
mand.
- 57-10 Joint Airborne Operations.
- 57-35 Airmobile Operations.
- 60-5 Amphibious Operations, Battalion in As-
sault Landings.
- 61-100 The Division.
- 100-5 Field Service Regulations; Operations.
- 100-10 Field Service Regulations; Administra-
tion.
- 100-11 Signal Communications Doctrine.
- 100-15 Field Service Regulations; Larger Units.
- 101-5 Staff Officers; Field Manual; Staff Or-
ganization and Procedure.
- 101-10 Staff Officers' Field Manual; Organiza-
tion, Technical and Logistical Data.
- 101-31 Staff Officers' Field Manual; Nuclear
Weapons Employment. (U)

c. Technical Manuals.

- 5-210 Military Floating Bridge Equipment.
- 5-220 Passage of Obstacles Other Than Minefields.
- 5-231 Mapping Functions of the Corps of Engineers.
- 5-232 Elements of Surveying.
- 5-233 Construction Surveying.
- 5-234 Topographic Surveying.
- 5-235 Special Surveys.
- 5-236 Surveying Tables and Graphs.
- 5-248 Foreign Maps.
- 5-250 Roads and Airfields.
- 5-251 Army Airfields and Heliports.
- 5-252 Use of Road and Airfield Construction Equipment.
- 5-260 Principles of Bridging.
- 5-277 Panel Bridge, Bailey Type, M2
- 5-295 Military Water Supply.
- 5-332 Pits and Quarries.
- 5-461 Engineer Handtools.
- 5-541 Control of Soils in Military Construction.
- 5-545 Geology and Its Military Applications.
- 5-725 Rigging.
- 57-210 Air Movement of Troops and Equipment.
- 57-220 Technical Training of Parachutists.

APPENDIX II

AIR-LANDING FACILITIES

Section I. INTRODUCTION

1. Purpose

This appendix provides information and guidance in the planning, site selection, and engineer support required for construction of air-landing facilities in airborne or other special operations.

2. Basic Information

In an airborne operation the nature of drop and landing zones is an important consideration in formulating the landing plan and scheme of maneuver. Drop zones and landing zones must provide for an initial disposition of troops which facilitates seizure of assigned objectives. The construction and improvement of air-landing facilities will be determined by the plan for building up troops and supplies in the objective area.

3. Use of Terms

a. Landing Area. This is the general area used for landing troops and material either by parachute or aircraft. It includes one or more drop zones, landing zones, or landing strips.

b. Landing Zone. Landing zones are specified sites within the objective area and are used for landing of assault aircraft during the assault or early phases of airborne or other special operations. These zones normally include minimum clearances for landing and

takeoff. In most instances, assault landings will be made on landing zones which have had little or no improvement (fig. 18). These landing zones, if suitable, may be improved by the development of air-landing facilities for continued operations.



Figure 18. Assault landing zone.

c. Air-Landing Facilities. These are facilities for landing, handling, and takeoff of aircraft which can be constructed to meet minimum essential requirements with full recognition given to the risks justified.

These facilities are selected to make maximum use of existing facilities, such as roads and compacted and level cleared fields. Pioneer effort is required to remove or mark obstacles, improve glide angles and landing clearance, and facilitate ground traffic.

d. Airfield. An airfield is a complex landing facility normally consisting of paved or surfaced runways and taxiways, operations tower, firefighting equipment, fuel storage facilities, permanent night lighting, water system, personnel messes and quarters, and other refinements.

4. Responsibilities

Construction or improvement of air-landing facilities in the objective area during the assault phase of an airborne operation is a responsibility of the airborne division engineer battalion. When construction requirements exceed its capabilities, the airborne division engineer battalion may be augmented by the attachment of elements or all of an airborne light equipment company, teams of key specialists such as soils technicians, or other engineer units as may be required for the accomplishment of the mission.

5. Number of Air-Landing Facilities

In an active nuclear situation, as many widely dispersed air-landing facilities and airfields should be seized as possible. Superhighways, roads, straight section of railroads, sports fields, and other areas which can be quickly converted to landing facilities must be given consideration to minimize the requirements for engineer effort.

a. The number of air-landing facilities provided in the objective area is situational and varies with—

- (1) Size of the airborne force to be employed and supported.
- (2) Planned buildup, including the number and type of aircraft to be accommodated.
- (3) Tactical and logistical plans.
- (4) Terrain in the objective area.
- (5) Enemy capabilities.
- (6) Engineer capabilities.
- (7) Weather during the time of operations.
- (8) Availability of local civilian resources.

b. The number and type of air-landing facilities to support an airborne operation are generally as follows:

- (1) One assault air-landing facility per committed brigade and one for use of the division as a whole.
- (2) One medium transport air-landing facility per division.

c. The above represents the desired minimum operational requirement for the airborne division and does not take into account the provisions for alternate or additional air-landing facilities to offset losses due to enemy action, particularly the destruction caused by nuclear weapons. These facilities do not necessarily provide for the employment of organic and attached Army aviation. To support operations in the objective area, it will generally be necessary to provide separate facilities for Army aviation.

d. The assault air-landing facilities in each brigade area and at division continue in use throughout the operation in order to provide sufficient facilities to accommodate the tonnage requirement during all phases of the operation; to provide flexibility for air-

landing due to enemy action; and to minimize the requirement for ground movement of supplies by delivering them as closely as possible to the using agency.

Section II. SITE SELECTION

6. Initial Planning

Site selection is the initial consideration in planning air-landing facilities because of the stringent operational criteria limitations imposed by assault aircraft, the effects of weather on flight operations, and construction activities. The airborne division engineer staff provides technical assistance in selection of specific air-landing facilities sites, based on the terrain in the area itself, and the engineer capability of the units available for the mission. Highways, railroads, sports fields, and other cleared areas which will require minimum clearance and leveling must be carefully considered.

7. Considerations for Site Improvement

If further operations in the objective area by the division are indicated, the air-landing facilities which are used during the initial phases may require further improvement. The necessary improvements to provide higher criteria facilities may create a requirement for more engineer troops, equipment, and material in the objective area than can be justified. Soils technicians are to be brought into the landing area as soon as possible to confirm engineering data and adjust locations of air-landing facilities if necessary.

8. Landing Zones for Assault Aircraft

Existing airfields, certain sections of superhighways,

some beaches, and a few existing open fields are suitable for assault landing facilities. These sites will generally require considerable improvement such as filling in craters and removing trees from approach zones. In addition to sufficient landing area, the landing zones should include adequate area for aircraft ground movement, loading, and unloading.

9. Desirable Characteristics

a. Desirable characteristics for landing zones are—

- (1) Close proximity to objectives.
- (2) Close proximity to dominating terrain, good road nets, and terrain favorable for defense against armored attack.
- (3) Relative freedom from antiairborne obstacles and anti-aircraft defenses.
- (4) A straight approach for aircraft.
- (5) Ease of identification, especially during periods of low visibility.
- (6) Cover and concealment in close proximity to landing areas.

b. Desirable characteristics for landing facilities are—

- (1) Clear approaches to landing strips.
- (2) Parking and dispersal areas to accommodate the planned capacity of the facility.
- (3) A road net to handle traffic to and from the facility.
- (4) Proximity of suitable assembly area.
- (5) Areas and other accommodations which facilitate supply and evacuation.

10. Criteria

Initial air-landing facilities for an airborne operation are established on acceptable minimum criteria, which are based primarily upon operational necessity and aircraft characteristics.

a. The minimum criteria air-landing facility is that which provides the minimum requirements of dimension and bearing capacity for a specific aircraft at a specific landing weight. This permits the initial use of the facility in a minimum of time.

b. In order to exploit the air capability under combat conditions, the minimum criteria will probably have to be lower. These criteria are to be determined by an acceptable takeoff and landing accident risk. Air Force technical orders list aircraft performance characteristics, and the commander of the unit furnishing the aircraft knows the capability of his pilots to meet these performance characteristics. He is therefore responsible for determining minimum criteria required for any specific air-landing facility.

11. Tactical Considerations

a. Site selection is the initial consideration in planning air-landing facilities because of the stringent construction time limitations imposed by airborne operations. Factors primarily affecting construction are weather, topography, drainage, ground cover, soil conditions, availability of local construction materials, and dispersion. The Army, Air Force, and Navy, as appropriate, have a joint responsibility for this important phase of planning. Site selection of landing zones and development of air-landing facilities will

depend directly upon the characteristics of the aircraft to be employed and the degree of risk to be accepted.

b. Success of the mission is the real overriding consideration in site selection. There may be instances where a site with undesirable characteristics is chosen because of tactical considerations. When an operation must have a certain air-landing capability within a specified time in order to succeed, then the provision of such a facility becomes a critical tactical consideration. However, a site which presents the deliverable engineer force with a task that it has no reasonable chance of accomplishing, can defeat the operation, even though that site meets all "ground combat" tactical requirements. Therefore, the selection of sites that are favorable for development of air-landing facilities is of utmost importance to tactical planners, because the success of the airborne operation depends upon the support furnished by cargo aircraft.

12. Engineer Considerations

In the selection of air-landing facility sites, the engineer is vitally interested in the characteristics of the locale of operations. Some of the factors he considers are—

a. Terrain in the objective area, with particular attention to—

- (1) Airfields that can be seized intact or rehabilitated.
- (2) Superhighways and other roads, beaches, or open areas of reasonably well-compacted soil.
- (3) Soil characteristics, relief, and vegetation.

- (4) Extent and nature of obstacles in the landing area.
- (5) Terrain studies of each site or area.
- (6) Current aerial photography coverage.
- (7) Effects of weather on soil conditions.
- (8) Condition of the road net.
- (9) Existing construction materials and other civilian resources in objective area.

b. Time limitations imposed on construction of air-landing facilities by tactical considerations.

c. Planned aerial delivery of construction equipment, based on division air movement tables.

d. When the engineer can apply the above facts to all potential air-landing sites and evaluate each site in specific terms of engineer effort, air-transport, and construction-time requirements, he will greatly facilitate the effective planning of airborne operations.

Section III. ENGINEER SUPPORT

13. Battalion Capability

The airborne division engineer battalion has the capability of improving air-landing facilities while concurrently providing engineer support to the brigades and the division.

14. Construction Support

The engineer construction support required will depend upon the type of work to be accomplished, the schedule of operations, and the criteria for the facilities. Support is furnished the airborne division engineer battalion by attachment from the airborne light equipment company or other engineer units with additional capabilities.

15. Employment

The airborne division engineer battalion employs its units to implement the air-landing facility plan by considering the following:

- a.* Number of landing zones and air-landing facilities to be cleared or constructed.
- b.* Engineer augmentation available.
- c.* Combat support missions for the airborne division which may reduce the air-landing facilities construction capability.
- d.* An analysis of terrain in the objective area.
- e.* Criteria established for the facilities.
- f.* Time allotted by the tactical needs of the division.
- g.* Local civilian resources.

INDEX

	Paragraphs	Pages
ADM:		
Battalion commander's responsibilities.	11a	7
In armor-airborne linkup.....	119	69
In denial operations.....	115	67
Administration:		
Engineer battalion	15	10
Engineer company	26, 34	22, 24
Headquarters and headquarters company	63	34
Airborne assault: Air movement, organization	97	53
Air-landing facilities	app. II	83
Amphibious:		
Equipment	117	68
Operations	120	72
Arctic operation	122	72
Assignment:		
Battalion	7	5
Equipment platoon	77	38
Headquarters and headquarters company	55	32
Platoon	40	25
Assistance to other arms.....	85	44
Aviation, Army, use.....	17	11
Battalion:		
Assignment	7	5
Commander's responsibilities	11a	7
Disposition in airborne operations....	94	49
Employment in landing zone.....	app. II	83
Movement	90	47
Operation	9, 82	6, 42
Organization	4	4
Organization of headquarters.....	11	7
Staff	11b, 64-72	9, 34
Bridge, capabilities	117	68
Capabilities:		
Battalion	8, 12	5, 9

	Paragraphs	Pages
Engineer company	23	19
Equipment platoon	78	38
Headquarters and headquarters company	56	32
Platoon	41	26
Squad	49	29
Combat operations:		
Committing engineer units.....	125	74
Introduction	124	73
Mission, type	125 <i>c</i>	74
Sustained	125	74
Command posts:		
Airborne assault	97 <i>d</i>	54
Alternate	97 <i>d</i> (2)	54
Drop or landing zone.....	16	11
Communications:		
Airborne assault	18 <i>b</i>	15
Equipment, radio, telephone.....	18	14
Composition headquarters and headquarters company, airborne division engineer battalion	4	4
Construction:		
Air landing facilities.....	app. II	83
Equipment	31, 38, 46, 75	23, 24, 27, 38
Control of platoon in assault.....	28 <i>b</i>	22
Coordination engineer unit committed in attack	126 <i>d</i>	78
Defense:		
Against airborne attack, guerrillas, infiltration	111	66
Against nuclear attack.....	110	64
Functions of engineers.....	108	63
Introduction	107	62
Denial operations:		
Implementations	114	67
Introduction	112	66
Prepositioned ADM's	115	67
Uses	113	66
Desert operations	121	72
Development of airhead after assault....	99	56

	Paragraphs	Pages
Disposition of battalion in airborne operations	94	49
Duties:		
Battalion commander	11a	7
Engineers in attack.....	104	61
Staff	11b	9
Employment:		
Battalion in airborne assault....	28, 35, 82	22, 24, 42
Engineers in landing zone.....	app. II	83
Equipment platoon	81	41
Headquarters and headquarters company in the assault.....	57	32
Methods	16	11
Platoon	43	26
Squad	50	29
Engineer effort:		
Airborne assault	97	53
Control	103	60
Reconnaissance	105	61
Support projects	98	56
Engineer work:		
Departure point	86	45
Destination	88	46
Roads	87	46
Traffic circulation	89	47
Equipment:		
Attached to companies.....	9b	6
Construction, airborne	5, 31, 77	4, 23, 38
Construction in headquarters and headquarters company	53, 56, 60	30, 32, 33
Equipment platoon	73-81	37
In company headquarters.....	31	23
In the platoon.....	38, 43	24, 26
In the squad.....	46	27
Maintenance	14	10
Major items	5	4
Exploitation of airhead after assault.....	99	56
Guides for commander of committed engineer unit	126	75
Landing zone	app. II	83

	Paragraphs	Pages
Maintenance:		
Capability of battalion.....	12e	10
Equipment platoon	79	40
Equipment	14, 24	10, 21
Section	71	37
Maps	66	35
Methods of employment of engineers. (See Employment.)		
Mission:		
Airborne division engineer battalion..	3	3
Battalion headquarters	10	7
Company headquarters	29	23
Engineer company	19	19
Engineer platoon	36	24
Engineer squad	44	27
Engineers in the attack.....	102	59
Equipment platoon	73	37
Headquarters and headquarters company	51, 58	30, 33
Type of combat role.....	125c	74
Mobility:		
Air	6	4
Battalion	6	4
Company	21	19
Company headquarters	32	23
Engineer platoon	39	25
Engineer squad	47	28
Equipment platoon	76	38
Headquarters and headquarters company	54, 61	32, 34
Organic	6	4
Mountain operations	123	73
Movement:		
By motor	92	48
Of battalion	90-93	47
Of division, tactical.....	91	48
Nuclear attack, defense.....	110	64
Operations:		
Airborne, planning	95	51
Amphibious	120	72

	Paragraphs	Pages
Arctic	122	72
Combat, general	124	73
Combat, sustained	125	74
Desert	121	72
Engineer company	35	24
Jungle	123	73
Methods	9	6
Mountain	123	73
River crossing	116	68
Staff	64	34
Organization:		
Air movement	97	53
Battalion headquarters	11	7
Engineer company	20, 30	19, 23
Equipment platoon	74	38
Headquarters and headquarters company	52, 59	30, 33
Platoon	37	24
Squad	45	27
Pioneer work done by other arms.....	106	62
Planning airborne operation.....	95	51
Platoon:		
Engineer, employment assault.....	28	22
Equipment	73-81	37
Preparation for support of bridges in airborne assault		
	96	53
Radio:		
Equipment	5, 18	4, 14
Net, battalion, company, platoon and bridge platoon.....	18a, 18b, 126	14, 15, 75
Reconnaissance, engineer	105	61
In armor-airborne linkup.....	119	69
References	app. I	79
Responsibility:		
Commander's, battalion	11a	7
For air-landing facilities.....	app. II	83
Staff	11b, 64	9, 34
River crossing:		
Capabilities	117	68

	Paragraphs	Pages
Conduct of operations.....	118	69
Operations, general	116	68
Security:		
Battalion headquarters	56	32
Unit	84	44
Site:		
Considerations for improvements..	app. II	83
Selection, for air-landing facilities, general	app. II	83
Specialists, key specialists attached to units	9c	6
Staff, airborne engineer battalion.....	11b, 64	9. 34
Standing Operating Procedure (SOP):		
Airborne engineer battalion.....	83	44
Unit	83, 126	44, 75
Supply:		
Class IV and V.....	17d	12
For division	17a, 8j	11, 5
Support of brigade in airborne assault....	96	53
Telephone equipment in airborne engi- neer battalion	5, 18	4, 14
Terrain intelligence	95a	51
Training:		
Airborne engineer battalion and other units	13	10
Company	25, 33	21, 23
Equipment platoon	80	41
Platoon	42	26
Water supply	17c	12
Withdrawal by air.....	100	58
Zone, landing. (See Landing zone.)		

BY ORDER OF THE SECRETARY OF THE ARMY:

G. H. DECKER,
General, United States Army,
Chief of Staff.

Official:

J. C. LAMBERT,
Major General, United States Army,
The Adjutant General.

Distribution:

Active Army:

DCSPER (1)	Corps (15)
ACSI (1)	Div (2) except Abn Div (10)
DCSOPS (10)	Abn Div Arty (2)
DCSLOG (30)	Abn Combat Arms Bde (5)
ACSRO (2)	Support Command (2)
ORD (2)	Abn Div Bn/Sqdns (3)
CINFO (1)	Abn Div Co/Trp/Btry (1)
TIG (1)	USATC Inf (10)
TJAG (1)	USATC Armor (10)
TPMG (1)	USMA (5)
Tech Stf, DA (2) except	USACGSO (5)
CofEngrs (5)	Br Svc Sch (5) except
TSG (1)	USAES (500)
USCONARC (20)	PMS Sr Div Units (1)
OS Maj Comd (20)	PMS Mil Sch Div Units (1)
LOGCOMD (5)	MAAG (5)
Armies (25)	Mil Msn (5)

NG: None.

USAR: Same as Active Army except allowance is one copy to each unit. For explanation of abbreviations used, see AR 320-50.

3000015568

7
v
.

.

.

PENTAGON LIBRARY



3000015568