

MHI  
Copy 3

# FM 22-5

DEPARTMENT OF THE ARMY FIELD MANUAL

---

*Walt*

*1/8*

## DRILL AND CEREMONIES



HEADQUARTERS, DEPARTMENT OF THE ARMY  
AUGUST 1958

**FIELD MANUAL**  
**DRILL AND CEREMONIES**

FM 22-5	}	HEADQUARTERS,
CHANGES No. 1	}	DEPARTMENT OF THE ARMY
		WASHINGTON 25, D.C., 8 April 1960

FM 22-5, 29 August 1958, is changed as follows:

## CHAPTER 4

### SCHOOL OF THE SOLDIER WITH ARMS

#### Section I.1. MANUAL OF ARMS FOR THE M14 RIFLE (Added)

##### 47.1. General

- a.* Execute FALL IN with the rifle at order arms.
- b.* Facings, alinements, and short distance marching movements are executed from order arms. Side step, backward march, open and close ranks, and close and extend are short-distance movements. Forward march may be given from order arms to march units forward for a short distance. When these movements are commanded while at order arms, it is necessary to come automatically to trail arms on the command of execution for the movement. The rifle is returned to order arms upon halting.
- c.* Before a command for any marching movement (other than the exceptions stated in *b* above) is given to armed troops, they are faced in the direction of march and their weapons brought to right shoulder, port, or sling arms by the appropriate command. After a marching movement has been completed and it is desired to execute a facing movement, the command to order or unsling arms is given, followed by the command for the facing movement.

*d.* When at a position other than sling arms, the troops must come to port arms for double time. When the troops are in formation, the commander gives the appropriate commands.

#### **47.2. Rules for the Rifle Manual of Arms**

*a.* The term "at the balance" refers to a point on the rifle (fig. 26.1) just forward of the magazine well. In this position the little finger of the left hand is placed on the lower band. While this is not the true balance of the rifle, it is used as a reference point for instructional purposes and to facilitate the manipulation of the weapon while performing the manual of arms.

*b.* The position of the rifle known as "diagonally across the body" (fig. 26.2) is as follows:

- (1) The left hand is at the balance, with the thumb and fingers grasping the rifle and sling. To do this, extend and join the fingers so as to form a U with the thumb.
- (2) The barrel is up and at such an angle that it bisects the juncture of the neck and shoulder. The heel of the butt is on line with the right hip (fig. 26.2).
- (3) The rifle is held at a height which allows the right forearm to be horizontal when the small of the stock is grasped with the right hand.
- (4) The distance of the rifle from the body depends upon the conformation of the body, but it should be about 4 inches from the belt.

*c.* The cadence for rifle movements is quick time, but in early stages of instruction the movements are done more slowly until the troops can execute them with precision. They are then practiced until the proper cadence is acquired.

*d.* The manual for the rifle is executed while standing at the position of attention. To add interest to drill

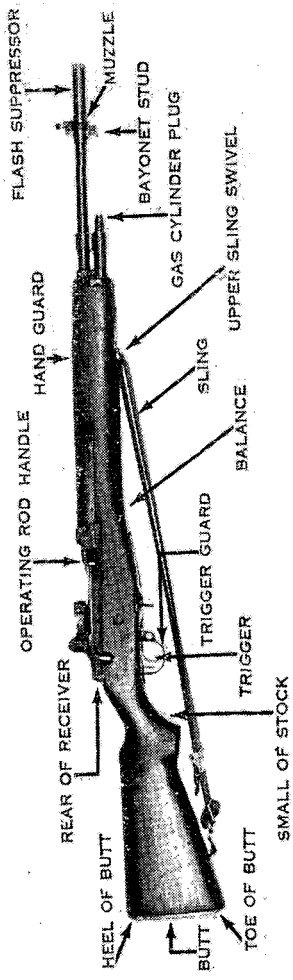

Figure 26.1. Drill nomenclature of the U.S. Rifle, 7.62-mm, M14.



*Figure 26.2. Rifle held diagonally across the body.*

and to lessen fatigue on long marches, movements between right and left shoulder and port arms may be commanded when marching at attention in quick time.

- (1) To move the rifle from the right shoulder to the left shoulder, **LEFT SHOULDER, ARMS** is commanded as the left foot strikes the ground. The first count of this movement is executed as the right foot strikes the ground and the left arm is swinging forward in its natural arc.
- (2) To move the rifle from the left shoulder to the right shoulder, **RIGHT SHOULDER, ARMS** is commanded as the right foot strikes the ground. The first count of this movement is executed as the left foot strikes the ground and the right arm is swinging forward in its natural arc.

*e.* The following positions are commanded from order arms only: inspection arms, trail arms, sling arms, fix and unfix bayonets, and the rest positions at order arms. Port arms is the only command that may be given from inspection arms.

*f.* The manual of arms with the magazine *in* the rifle is restricted to inspection arms, port arms, sling and un-sling arms, order arms, trail arms, and fix and unfix bayonets.

### **47.3. Order Arms**

*a.* Order arms is the position of the soldier at attention with the rifle. It is assumed on the command **SQUAD (PLATOON), ATTENTION** from any of the rest positions except fall out. Order arms is assumed on the command **FALL IN** and on the command **ORDER, ARMS** from any position in the manual except inspection arms and sling arms.

*b.* At order arms, the position of attention is maintained except for the right arm and rifle. The rifle butt is placed on the ground with the barrel to the rear and the toe of the rifle butt against and on line with the toe of

the right shoe. The upper part of the handguard is grasped with the right hand in a V formed by the fingers and the thumb. The fingers are placed diagonally so the tips of the index finger and the thumb are grasping the sides of the stock; the right arm is kept behind the rifle so the thumb is along the trousers seam (fig. 26.3).

#### **47.4. Rest Positions With the Rifle**

Rest positions with the rifle are commanded and executed as without arms (par. 20), with the following exceptions and additions.

*a.* On the command **PARADE, REST**, the left foot is placed 12 inches from and on line with the right foot. The rifle butt is kept against the right foot, the butt toe on line with the shoe toe. The barrel of the rifle rests against the hip along the seam of the trousers as in the position of attention (1, fig. 26.4). The grasp of the rifle is unchanged. The left hand is placed behind the back just below the belt line with the fingers and thumb extended and joined and the palm facing the rear (2, fig. 26.4).

*b.* To execute **STAND, AT EASE**, the parade rest position is assumed and the head and eyes are turned toward the commander.

*c.* On the command **AT EASE**, or **REST**, the right foot remains in place and the rifle is held as in parade rest with the right arm relaxed slightly.

*d.* When at sling arms, rest positions are commanded and executed as described in paragraph 47.13*e*.

*e.* Armed troops must be at attention at order arms, port arms, stack arms, or unsling arms before **FALL OUT** may be given.

#### **47.5. Trail Arms**

*a.* For instructional purposes, the command **TRAIL, ARMS** may be used to teach the position at a halt. At the command **ARMS**, the rifle is raised vertically 3 inches



*Figure 26.3. Order arms.*





*Figure 26.4. Parade rest.*



2

*Figure 26.4—Continued.*

off the ground with the wrist straight and the thumb along the seam of the trousers; the grasp of the rifle does not change (fig. 26.5). This movement is executed in one count.

*b.* At the command **ORDER, ARMS** the rifle is lowered vertically to the position of order arms. For instructional purposes when **TRAIL, ARMS** is commanded, the rifle is held at the trail until **ORDER, ARMS** is given.

#### **47.6. Port Arms**

*a.* The command is **PORT, ARMS**.

*b.* This is a 2-count movement from order arms. At the command **ARMS**, the rifle is raised diagonally across the body with the right hand; the left hand grasps the rifle at the balance and holds it so that it is 4 inches from the belt. The right elbow is held down without strain (1, fig. 26.6). On the second count, the rifle is regripped with the right hand at the small of the stock, fingers and thumb closed around the stock (2, fig. 26.6). The right forearm is horizontal and the elbows are against the sides.

*c.* From port arms to order arms is a 3-count movement. At the command **ARMS**, the right hand is moved to regrip the upper part of the handguard without moving the rifle (1, fig. 26.6). On the second count, the left hand is removed from the balance, and the rifle is lowered to the right side with the right hand until the butt is 3 inches from the ground. The left hand is placed immediately below the bayonet stud, fingers and thumb extended and joined, palm to the rear, to steady the rifle and hold the barrel vertical (fig. 26.7). On the third count, the left hand is cut sharply to the side while the rifle is lowered gently to the ground.

#### **47.7. Right Shoulder Arms**

*a.* The command is **RIGHT SHOULDER, ARMS**.

*b.* When executed from order arms, right shoulder arms is a 4-count movement. At the command **ARMS**,

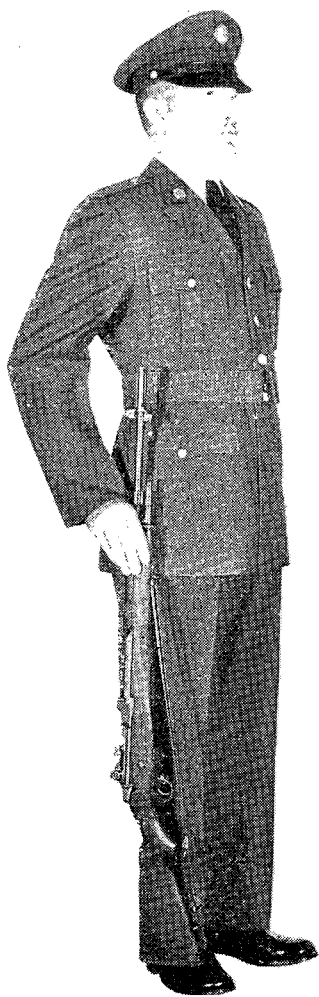

*Figure 26.5. Trail arms.*



*Figure 26.6. Port arms.*



*Figure 26.6—Continued.*



*Figure 26.7. Next to last count of order arms.*

the first count of port arms is executed as described in paragraph 47.6 (1, fig. 26.8). The right elbow is held down without strain. On the second count, the rifle is regrasped at the butt with the right hand, the heel of the butt between the first two fingers, and the thumb and fingers closed around the heel with the thumb and forefinger touching (2, fig. 26.8). On the third count, the rifle is placed on the right shoulder with the grasp of the right hand unchanged. At the same time, the left hand is moved from the balance to the small of the stock where it is used to guide the rifle to the shoulder (3, fig. 26.8). The thumb and fingers are extended and joined with palm turned toward the body. The first joint of the left forefinger touches the rear of the receiver. The left elbow is kept down. On the fourth count, the left hand is cut smartly back to its position by the side, as at attention. The right forearm is horizontal with the right elbow against the side and on line with the back (4, fig. 26.8).

*c.* The return to order arms is a 4-count movement. On the command ARMS, the rifle butt is pressed down quickly and the rifle is guided diagonally across the body. At the same time, the butt is turned to keep the barrel up. The rifle is grasped smartly at the balance with the left hand and the grasp of the right hand is retained on the butt (count one). On the second count, the right hand is moved up and across the body to grasp the upper part of the handguard. The third and fourth counts are the same as the second and third counts used in executing order arms from port arms (par. 47.6).

*d.* Right shoulder arms from port arms is a 3-count movement. On the first count, the rifle is grasped at the butt with the right hand as in coming to right shoulder from order arms. The last 2 counts are the same as the last 2 counts in moving from order to right shoulder arms.





*Figure 26.8. Right shoulder arms.*

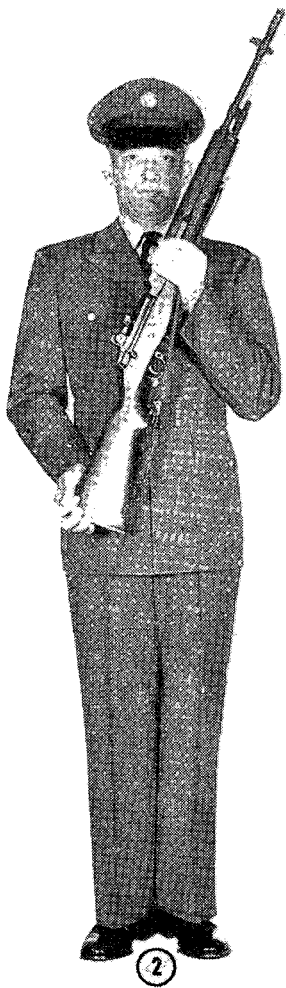

*Figure 26.8—Continued.*



*Figure 26.8—Continued.*



*Figure 26.8—Continued.*

*e.* Port arms from right shoulder arms is a 2-count movement. The first count is the same as the first count from right shoulder to order arms. On the second count, the rifle is regrasped with the right hand at the small of the stock in the position of port arms.

#### **47.8. Left Shoulder Arms**

*a.* The command is **LEFT SHOULDER, ARMS.**

*b.* To move the rifle to left shoulder arms from the order, the rifle is brought to port arms in the first two counts (fig. 26.6). On the third count, the rifle is placed on the left shoulder with the right hand and the right arm is pressed against the body. The butt is grasped with the left hand as shown in 1, figure 26.9. On the fourth count, the right hand is cut smartly to the side in returning to the position of attention (2, fig. 26.9).

*c.* Port arms from left shoulder arms is a 2-count movement. On the first count, the right hand moves up and across the body and grasps the small of the stock and the right arm is pressed against the body (1, fig. 26.9). On the second count, the rifle is brought diagonally across the body with the right hand and regrasped at the balance with the left hand as in the position of port arms (2, fig. 26.6).

*d.* Order arms or right shoulder arms from left shoulder arms is a 5-count movement. On the first 2 counts, the rifle is brought to port arms. On the last 3 counts, it is possible to go to order arms or right shoulder arms as described in paragraphs 47.3 and 47.7.

#### **47.9. Present Arms**

*a.* The command is **PRESENT, ARMS.**

*b.* Order arms to present arms is a 2-count movement. On the first count, the rifle is raised and carried to the center of the body. It is held vertical, approximately 4 inches from the body with the barrel to the rear. The



*Figure 26.9. Count 3 of left shoulder arms from order arms.*



*Figure 26.9—Continued.*

right elbow is down. The rifle and sling are grasped at the balance with the left hand. The left forearm is horizontal and the left elbow is against the side (1, fig. 26.10). On the second count, the right hand regrasps the rifle at the small of the stock (2, fig. 26.10).

*c.* Order arms from present arms is a 3-count movement. On the first count, the rifle is grasped at the upper part of the handguard with the right hand (1, fig. 26.10) with the right elbow kept down and against the side. The rifle is lowered to the ground with the right hand on counts 2 and 3 as in port arms to order arms (fig. 26.7).

*d.* Port arms from present arms is executed in one count. The rifle is raised and twisted with the right hand, the muzzle moves to the left, and the rifle is regrasped at the balance with the left hand (2, fig. 26.6).

*e.* Present arms from port arms is executed in one count. The rifle is lowered and twisted with the right hand while being moved into a vertical position where it is regrasped at the balance with the left hand.

#### **47.10. Inspection Arms (Without the Magazine)**

*a.* The command is INSPECTION, ARMS. It is a 4-count movement, executed only from order arms.

*b.* At the command ARMS, the rifle is raised diagonally across the body with the right hand and is grasped with the left hand at the balance as in the first count of port arms (par. 47.6*b*). On the second count, the right hand grasp is released and the right hand slides down the rifle with the fingers extended and joined, until the knife edge of the hand comes in contact with the operating rod handle. At this time, the thumb is on the opposite side of the receiver (1, fig. 26.11). On the third count, the operating rod handle is pressed sharply to the rear and the bolt lock is depressed with the thumb so that the bolt is locked in the rearmost position. At the same time, the head and eyes are lowered to check the receiver (2, fig. 26.11). On the fourth count, hav-





*Figure 26.10. Present arms.*

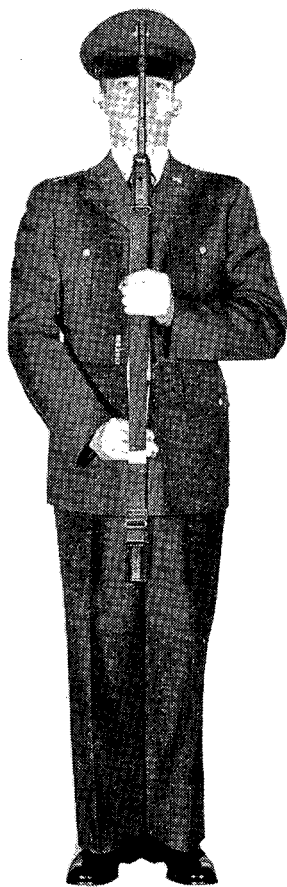

②

*Figure 26.10—Continued.*



*Figure 26.11. Inspection arms without magazine.*



*Figure 26.11—Continued.*

ing found the receiver empty or having emptied it, the head and eyes are raised to the front and the rifle is regrasped at the small of the stock as in port arms.

*c.* PORT, ARMS is the only command that is given from inspection arms. On the preparatory command, the grip on the small of the stock is relaxed to permit the index finger to hook around the operating rod handle, pulling it slightly to the rear so that the bolt lock will be released (1, fig. 26.12). At the command ARMS, the operating rod handle is released, the trigger pulled, and the small of the stock regrasped in the position of port arms.

#### **47.11. Inspection Arms (With the Magazine)**

*a.* The command is INSPECTION, ARMS. It is a 4-count movement with the first two counts the same as inspection arms without the magazine. On the third count, the operating rod handle is pressed sharply to the rear with the knife edge of the right hand until the bolt engages the magazine follower. At the same time, the head and eyes are lowered to check the receiver. On the fourth count, having found the receiver empty or having emptied it, the head and eyes are raised and the rifle is regrasped at the small of the stock as in port arms.

*b.* PORT, ARMS is the only command given from inspection arms. On the preparatory command, the right hand releases the rifle and, with fingers extended and joined, the knife edge of the hand is pressed against the operating rod handle. After the operating rod handle is pressed slightly to the rear, the thumb is inserted in the rearmost part of the receiver to depress the magazine follower. The bolt is allowed to slide forward slightly (2, fig. 26.12). On the command ARMS, the operating rod handle is released. The right hand is returned to the small of the stock, the trigger is pulled, and the position of port arms is assumed.



*Figure 26.12. Port arms from inspection arms.*



*Figure 26.12—Continued.*

## 47.12. Rifle Salute

*a.* This movement may be executed from order arms, trail arms, right shoulder arms, or left shoulder arms. For instructional purposes, the command RIFLE, SALUTE may be used. The rifle salute is a 2-count movement.

*b.* When at order arms, the left arm moves across the body on the first count, with the forearm and wrist straight, fingers and thumb extended and joined, and palm down. The first joint of the forefinger touches the rifle at a point below the bayonet stud (1, fig. 26.13). If not in ranks, the head and eyes turn toward the person or color saluted. On the second count, the left hand is cut smartly to the side and the head and eyes are turned to the front.

*c.* When saluting at trail arms, the movements are identical with those for saluting at order arms, except that the rifle is held in the trail arms position.

*d.* At right shoulder arms, the movement is executed by moving the left arm across the chest and touching the first joint of the forefinger to the rear of the receiver. The left elbow is held so that the left forearm is horizontal. Fingers, thumb, and wrist are held as described in *b* above. The palm is down (2, fig. 26.13). The second count of the rifle salute at right shoulder arms is similar to the return from the rifle salute at order arms.

*e.* At left shoulder arms, the salute is executed by moving the right arm across the chest and touching the first joint of the forefinger to the rear of the receiver. The right elbow is held so that the forearm is horizontal. The fingers, thumb, and wrist are as described in *b* above. The palm is down. The second count is similar to the return from the rifle salute at right shoulder arms.

## 47.13. Sling and Unsling Arms

*a.* The command SLING, ARMS is given only from





*Figure 26.13. Rifle salute.*

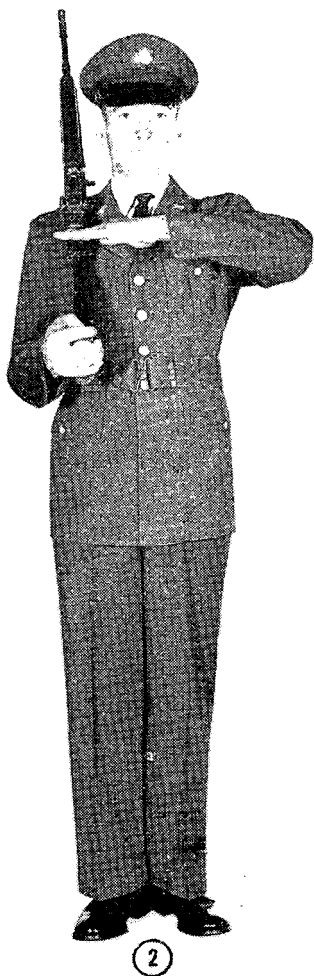

*Figure 26.13—Continued.*



*Figure 26.14. Sling arms.*

order arms. This movement is not executed in cadence. If the sling is not adjusted, the butt of the rifle is placed on the right hip and the rifle is cradled in the crook of



*Figure 26.15. Fix and unfix bayonets.*

the right arm at the command of execution. The sling is adjusted with both hands and the rifle is then slung over the right shoulder in the most convenient manner.

When at sling arms, the sling is grasped with the right hand, keeping the right forearm horizontal and holding the barrel of the rifle vertical (fig. 26.14). If the sling is already adjusted, the rifle is slung in the most convenient manner at the command of execution.

*b.* The command UNSLING, ARMS is given only from the position of sling arms. At the command of execution, the rifle is unslung and brought to the position of unsling arms by steadying the rifle with the left hand. The positions of order arms and unsling arms are the same except that at unsling arms the sling is loose.

*c.* So that precise movements of the manual can be executed, the command ADJUST, SLINGS is given. At the command SLINGS, the sling is tightened as described in *a* above.

*d.* To salute while at sling arms, on the command ARMS of PRESENT, ARMS, the sling is grasped with left hand to steady the rifle. The palm of the left hand is to the rear and the forearm is horizontal. At the same time, the sling is released with the right hand and the first count of the hand salute is executed as described in paragraph 22. At the command ARMS of ORDER, ARMS, the right hand and arm are moved smartly to the side as in the position of attention and then the original position of sling arms is resumed.

*e.* When at sling arms, parade rest, rest, at ease, and stand at ease are executed as from order arms except that the rifle is held slung with the right hand. When the command REST is given, the rifle may be unslung. When calling a squad or platoon to attention, the position of parade rest at sling arms is assumed on the preparatory command.

#### **47.14. Fix and Unfix Bayonets**

*a.* These movements are not executed in cadence.

*b.* On the command FIX, BAYONETS (when the

bayonet scabbard is on the belt), the muzzle of the rifle is moved across the body and regripped with the left hand below the gas cylinder plug. The snap on the scabbard is unfastened and the bayonet is gripped with the right hand, as shown in figure 26.15. The bayonet is drawn from the scabbard. The point of the bayonet is turned skyward and the bayonet is fixed on the muzzle with a downward movement. After the bayonet is fixed, the position of attention is assumed.

*c.* The command UNFIX BAYONETS is given at order arms only.

*d.* At the command BAYONETS, when the bayonet scabbard is on the belt, the rifle is moved to the left hand as when fixing bayonets. The rifleman glances down and grasps the handle of the bayonet with the right hand, the palm toward the body. The bayonet catch spring is pressed with the inside of the forefinger. The bayonet is raised vertically until the handle is approximately a foot above the muzzle of the rifle. Then, keeping the eyes on the point of the bayonet, the rifleman returns the bayonet to the scabbard, reversing the movements of its withdrawal. The snap on the bayonet scabbard is fastened with the left hand and the position of order arms is assumed.

*e.* When the bayonet is carried other than on the belt, it is fixed and unfixing in the most convenient manner possible upon receiving the commands.

*f.* Safety precautions should be observed when fixing bayonets while the rifle is held diagonally across the body with the left hand. Tap the base of the bayonet handle with the heel of the right hand, to make sure that the bayonet is secure. If resistance is met when unfixing the bayonet, thrust the bayonet into the ground, blade facing the right toe. Then press the bayonet release with the toe of the right boot and remove the rifle from the bayonet. The blade of the bayonet is not touched with the bare hands.

## CHAPTER 5

### THE SQUAD

#### Section II. SQUAD DRILL

##### 72.1. To Stack Arms, U.S. Rifle, 7.62-MM, M14 (Added)

*a.* The members of the squad stack arms from their positions in line at normal interval on the command of **STACK, ARMS**. After the squad counts off, the commander designates the stackmen by numbers then gives the command **PREPARE, SLINGS**.

*b.* At the command **SLINGS**, the stackman places the butt of his rifle on his right hip and cradles it in the crook of his right arm (1, fig. 41.1). He then adjusts the sling keeper to form a 4-inch loop (a palm's width within the loop) next to the upper sling swivel (2, fig. 41.1). As soon as he has prepared the loop, the stackman returns to order arms. After all stackmen are at order arms, the command, **STACK, ARMS** is given.

*c.* At the command **ARMS**, the stackman places his rifle directly in front of and centered on his body with the sling facing to the front (1, fig. 41.2). The heel of the rifle butt is on the ground on line with the toes of his shoes. The stackman grasps the rifle by the hand-guard with his left hand. The first two fingers of the left hand hold the inner part of the loop against the rifle. He reaches across the front of the rifle with the right hand, grasps the outer part of the loop, and holds it open for the insertion of the other rifles (2, fig. 41.2). He holds the rifle vertical at all times.

*d.* After the base rifle has been positioned, the men right and left of the stackman perform the following movements simultaneously:

- (1) The man on the stackman's left raises and rotates his rifle, sling up, to a horizontal position

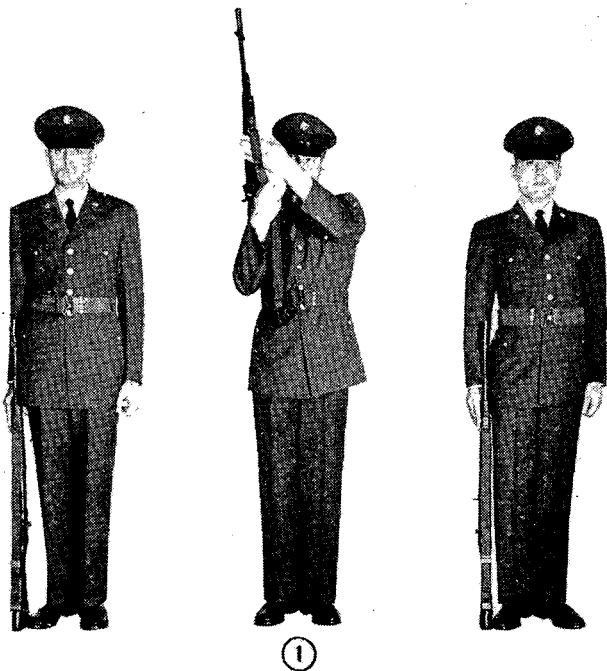

*Figure 41.1. Preparing sling to stack arms.*

- across his body, muzzle to the right. At the same time, he grasps the rifle at the small of the stock with the left hand, palm downward, over the sling. He continues to grasp the upper part of the handguard with his right hand. He lets both arms hang naturally, holding the weapon in a horizontal position (3, fig. 41.2).
- (2) The man on the stackman's right moves his rifle vertically and across his body with his right hand until his wrist is shoulder high in the center of the body. He grasps the weapon with



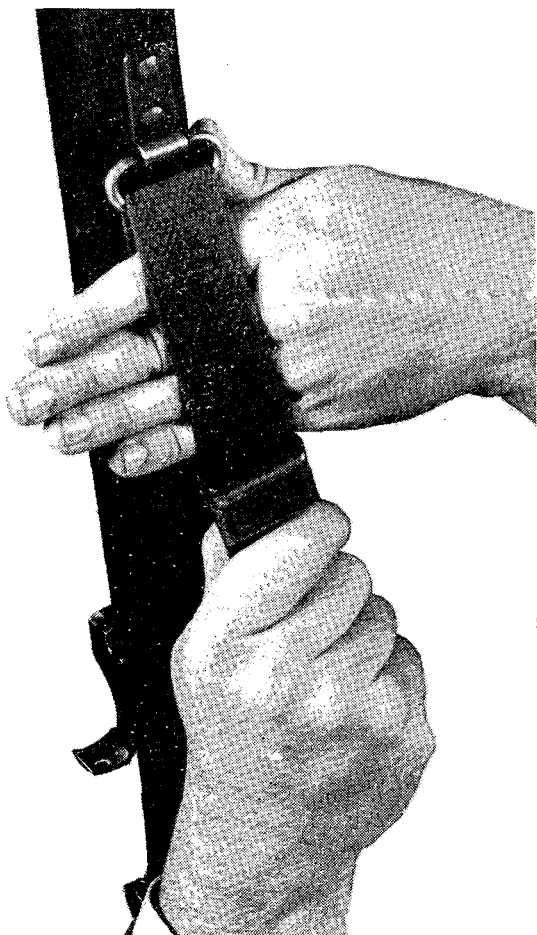

②

*Figure 41.1—Continued.*

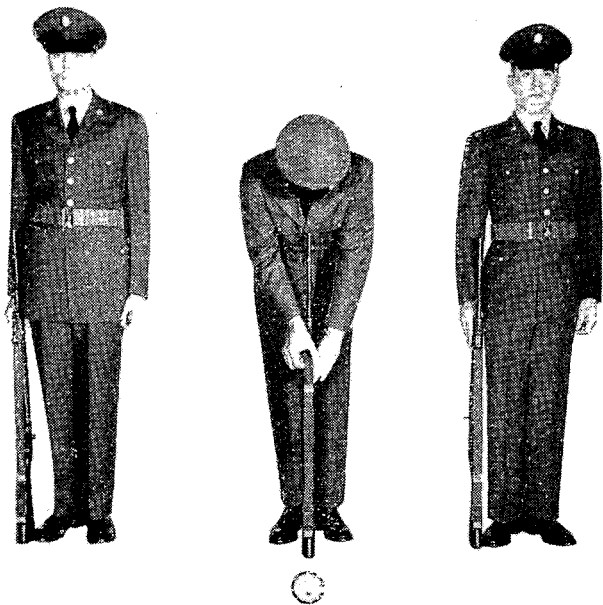

*Figure 41.2. Stack arms.*

his left hand immediately under the right hand, palm over the sling. He then lowers his right hand to the small of the stock, palm facing the sling, and turns the rifle until the sling is up, muzzle to the left, and the rifle is in a horizontal position. He lets his arms hang naturally (3, fig. 41.2).

- (3) As soon as both men have completed these movements, each moves his foot that is nearest the stackman 18 inches to the oblique and toward the stackman. In a continuing motion, the man on the stackman's left inserts the



2

Closeup of loop in sling  
*Figure 41.2—Continued.*

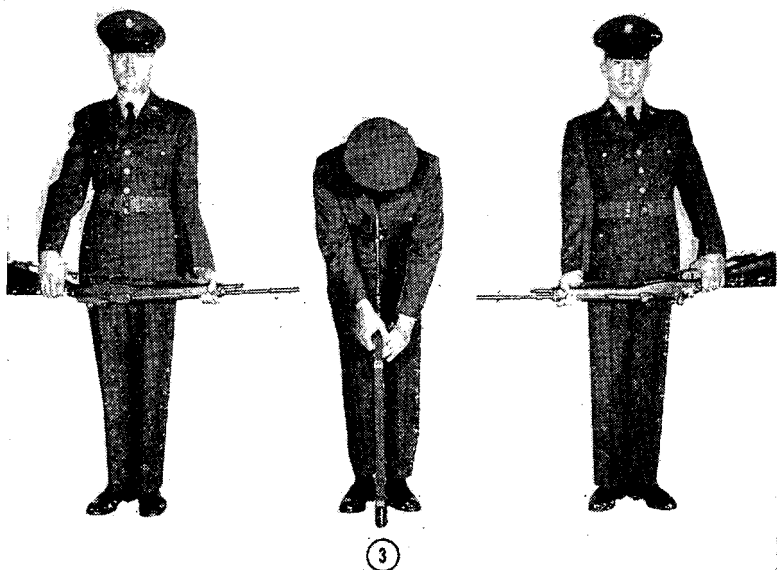

*Figure 41.2—Continued.*

muzzle of his rifle into the loop held by the stackman until the bayonet stud protrudes past the far end of the loop (4, fig. 41.2). He holds his weapon in this position until the man on the stackman's right inserts the muzzle of his rifle through the loop in the same manner and above the muzzle of the rifle of the left man (4, fig. 41.2).

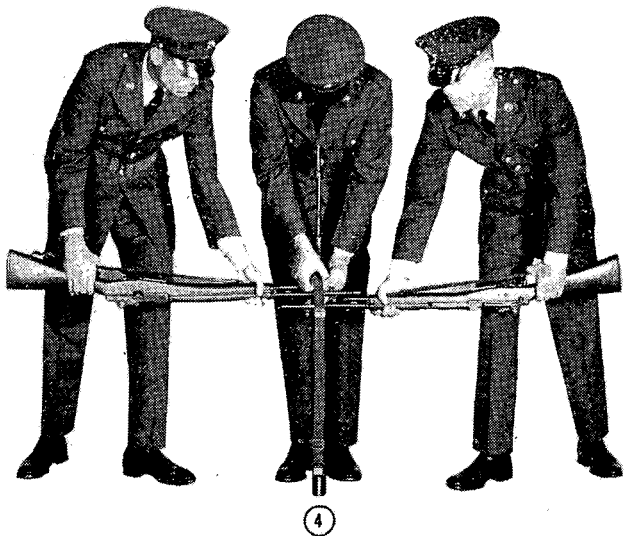

Figure 41.2—Continued.

*e.* When both rifles have been inserted into the loop, the men on each side of the stackman swing the butts of their rifles outward and down to the ground until the stack is tight with the rifle butts on line and approximately 2 feet from the base line (5, fig. 41.2).

*f.* After necessary adjustments have been made, all three men come back to the position of attention (5 and 6, fig. 41.2).

*g.* Extra rifles are passed to the nearest stack on the right. As each rifle is passed, it is grasped at the upper part of the handguard with the right hand. Then, with the rifle held vertical, it is passed with fully extended arm to the right front. The man on the right grasps the rifle at the balance with his left hand, brings the rifle to the center of his body, and regrasps it at the

upper part of the handguard with his right hand. This action continues until the stackman receives the rifle and places it on the stack with his right hand as nearly vertical as possible. He places the rifles on the stack with the slings away from the stack.

## **72.2. Take Arms, U.S. Rifle, 7.62-MM, M14**

(Added)

*a.* The squad in position, on line behind the stacks, takes arms at the command TAKE, ARMS.

*b.* At the command ARMS, the stackman passes each extra rifle towards its bearer. The rifles are handled in the manner described for passing them to the stack (left hand at the balance, right hand at the upper part of the handguard). As the men receive their weapons, they resume the position of order arms.

*c.* After all extra rifles have been returned, the stackman grasps the base rifle, holding the loop open as in stack arms.

*d.* The men to the right and left of the stackman take one step to their left and right fronts, respectively. They reach down and grasp their rifles, bringing them to a horizontal position. They grasp the rifles as shown in 4, figure 41.2. The man to the right of the stackman frees his rifle from the stack first. Each man returns to order arms after retrieving his rifle. He does this by guiding and steadying the rifle with his left hand as in the next to the last count of order arms (fig. 26.7).

*e.* The stackman adjusts the sling of his rifle before returning to order arms.

## **118. March in Review**

\* \* \* \* \*

*i.* When the reviewing \* \* \* and flourishes only. The reviewing officer salutes at his discretion. Other

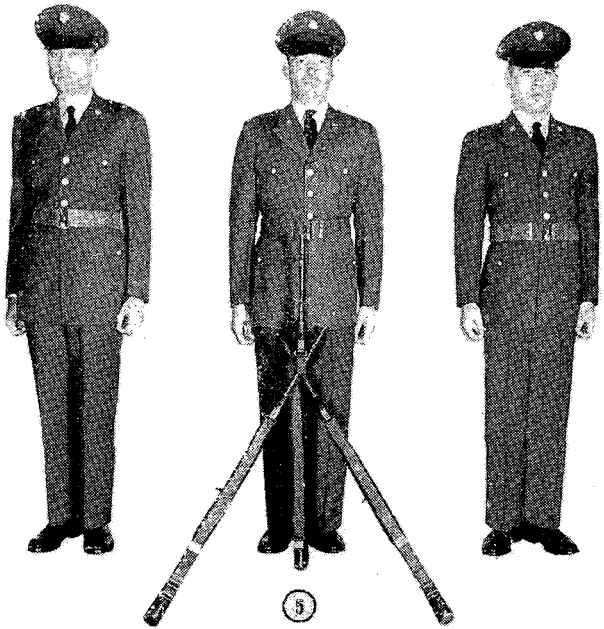

Figure 41.2—Continued.

members of the reviewing party do not salute. The bandmaster and \* \* \* 12 steps distance.

\* \* \* \* \*

*k.* At the command \* \* \* and eyes right. The reviewing officer returns the salute of the commander of troops and commanders of the next subordinate echelon. Other members of the reviewing party do not salute.

\* \* \* \* \*

### 127.1. Use of Women as Color Guards

(Added)

*a.* Members of the Women's Army Corps may be

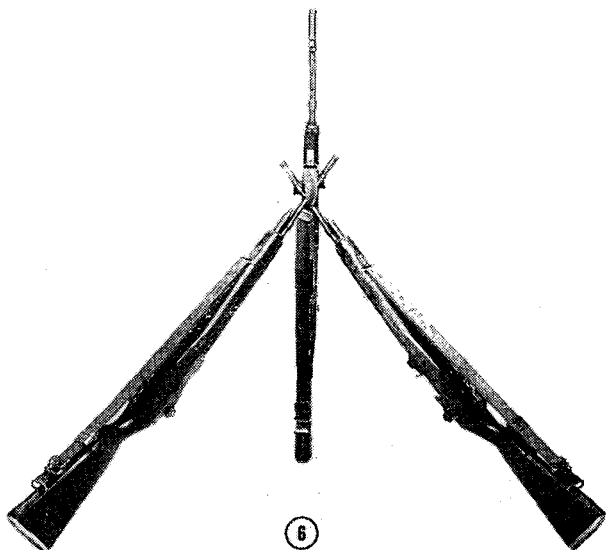

*Figure 41.2—Continued.*

called upon to provide contingents for parades and ceremonies. The color guards for such occasions may, at the discretion of the local commander, be composed of female personnel.

*b.* When the color guard is composed of female personnel, it will be designated by the term **COLOR ESCORT**. Color escorts will not bear arms nor require armed male guards.

[AG 353 (15 Feb 60)]



By Order of *Wilber M. Brucker*, Secretary of the  
Army:

Official:

**R. V. LEE,**  
*Major General, United  
States Army,  
The Adjutant General.*

**L. L. LEMNITZER,**  
*General United States  
Army,  
Chief of Staff.*

Distribution:

*Active Army:*

CNGB (1)	Brig (3)
DCSPER (2)	Regt/Gp/bg (5)
ACSI (2)	Bn (5)
DCSOPS (2)	Co/Btry (3)
DCSLOG (2)	Ft & Camps (Submitting DA Form 12) (2)
ACSRC (2)	USMA (1045)
Tech Stf, DA (1)	USAWC (5)
Tech Stf Bd (2)	USACGSC (15)
USCONARC (15)	Br Svc Sch (5) except
USA Arty Bd (2)	USAARMS (850)
USA Armor Bd (2)	USACMLCSCH (62)
USA Inf Bd (2)	USAES (12)
USA Air Def Bd (2)	AMSS (550)
USA Abn & Elct Bd (2)	USA Ord Sch (700)
USA Avn Bd (2)	USA QM Sch (650)
USA Arctic Test Bd (2)	USASCS (10)
US ARADCOM (2)	USATSCH (200)
US ARADCOM Rgn (2)	USAIS (981)
OS Maj Comd (5)	PMST Sr Div Units (5)
OS Base Comd (5)	PMST Jr Div Units (5)
LOG Comd (3)	PMST Mil Sch Div Units (5)
MDW (2)	ROTC and NDCC Units (1 ea student)
Armies (5) except	USATC (25)
First US Army (7)	USA Corps (Res) (3)
Corps (5)	
Div (5) (Ea CC) (5)	
NG: State AG (3); units—same as Active Army except allowance is (3) copies per unit.	
USAF: Same as Active Army.	
For explanation of abbreviations used, see AR 320-50.	

FIELD MANUAL

No. 22-5

HEADQUARTERS,  
DEPARTMENT OF THE ARMY  
WASHINGTON 25, D. C., 29 August 1958

## DRILL AND CEREMONIES

	Paragraphs	Pages
CHAPTER 1. INTRODUCTION		
Section I. General.....	1-3	3
II. Drill instruction.....	4-6	5
CHAPTER 2. COMMANDS AND THE COMMAND VOICE		
Section I. Commands.....	7, 8	11, 12
II. The command voice.....	9-16	13
CHAPTER 3. SCHOOL OF THE SOL- DIER WITHOUT ARMS.	17-34	21
4. SCHOOL OF THE SOL- DIER WITH ARMS		
Section I. Manual of arms for the rifle..	35-47	39
II. Manual of arms for the auto- matic rifle.....	48, 49	67, 68
III. Manual of arms for the pistol..	50-52	68
IV. Manual of arms for the car- bine.....	53-55	74
V. Manual of the guidon.....	56-60	79
CHAPTER 5. THE SQUAD		
Section I. General.....	61-63	88
II. Squad drill.....	64-75	92
CHAPTER 6. THE PLATOON		
Section I. General.....	76-80	109
II. Platoon drill.....	81-88	114
CHAPTER 7. THE COMPANY		
Section I. General.....	89, 90	123, 128
II. Company drill.....	91-104	130

\*This manual supersedes FM 22-5, 27 August 1956, including C 1, 25 June 1957.

	Paragraphs	Pages
CHAPTER 8. INSPECTIONS.....	105-107	142
9. THE BATTLE GROUP		
Section I. General.....	108, 109	153, 154
II. Formations and movements..	110, 111	154, 157
CHAPTER 10. CEREMONIES		
Section I. Reviews.....	112-119	161
II. Parades.....	120-122	176
III. Escorts and honor guards....	123, 124	182, 183
IV. Colors and standards.....	125-132	186
V. Funerals.....	133-148	193
CHAPTER 11. MOUNTED DRILL		
Section I. General.....	149-162	211
II. Movement of vehicles.....	163-168	219
III. Signals.....	169, 170	227
IV. Mounted reviews.....	171-176	229
V. Inspection of mounted units..	177, 178	235, 238
APPENDIX I. REFERENCES .....		239
II. SYMBOLS.....		240
INDEX.....		241

# CHAPTER 1

## INTRODUCTION

---

### Section I. GENERAL

#### 1. Purpose and Scope

This manual presents army drill and ceremonies. It gives the techniques for teaching drill and ceremonies; the methods for developing the command voice; the school of the soldier; the manual of arms for the rifle, automatic rifle, pistol, and carbine; manual of the guidon; unit drill through units of battle group size; and ceremonies, inspections, and mounted drill.

#### 2. Definitions, Symbols, Capitalization

*a. Definitions* of drill terms used in this manual usually appear at the beginning of each chapter in which they are first used.

*b. Symbol keys* accompany figures, and a reference key for all symbols appears in appendix II, figure 71.

*c. Capitalization.* *Preparatory commands* (par. 7) and *supplementary commands* (par. 8) are shown in SMALL CAPITALS and *commands of execution* (par. 7) in LARGE CAPITALS. *Combined commands* (par. 7) are also shown in LARGE CAPITALS although they are sometimes used as *supplementary commands*.

### 3. Drill and Ceremonies

*a.* During his first few weeks in the army the soldier often asks, "Why are drill and ceremonies needed? Why couldn't I use my time more advantageously learning how to fire my weapon?" The answers are that individual efforts alone do not bring survival or victory for the soldier; that the soldier has to learn teamwork and the value of unified and cooperative action so thoroughly that they guide his later actions instinctively. The first opportunity that the army has to build the spirit of teamwork is on the parade ground. Here, all soldiers learn that there can be no orderly movement of men or units without a precise and united effort, and every man learns to play his part in the squad, platoon, or company. The commands for drill and ceremonies take on a meaning similar to the signals barked out by the quarterback on a football team. After a short time the soldier knows what to do in response to a command. He also knows what his friends will do and his confidence grows in himself and his friends. Teamwork results, unit pride grows, and a solid foundation is established for further training of all types.

*b.* Drill consists of certain movements by which the squad, platoon, or company is moved in an orderly manner from one formation to another or from one place to another. These movements are executed with order and precision. Each member of the squad does his part with exactness so that on command the squad moves instantly, smartly, and smoothly. The men are trained to stand, step off, march, halt, and to handle the rifle smoothly as individuals and in unison as members of the squad.

*c.* Drill training begins the day the soldier enters the army. In the beginning, he is taught individually the foot movements and the manual of arms. Immediately following this instruction, he practices these movements while marching, halting, and in combination with the handling of his weapon. He repeats the exercises until he can perform them smartly and automatically in response to a command. He is then placed in a squad and trained to do all these movements together with other men. His squad is then placed in a platoon with other squads, where he learns other movements. Finally, he takes his place in companies and battle groups.

*d.* Ceremonies are formations and movements in which a large number of troops execute movements in unison and with precision upon command just as in drill. Although the colors and standards and the martial music add color to military ceremonies, their primary value is in rendering honors, preserving traditions, and stimulating esprit de corps. A ceremony may inspire hundreds or even thousands of men to work as a great team; standing at attention in ranks, making 1,000 rifles click like one, or marching with machinelike precision. Esprit de corps is generated and every soldier in the unit becomes proud of himself and his unit as a result of snappy appearance and precise group performance.

## **Section II. DRILL INSTRUCTION**

### **4. Conduct of Instruction**

*a.* The progress made by individuals and units in precise and unified action in drill and ceremonies is determined by—

- (1) The methods of instruction and the thoroughness of the instructors.
- (2) The organization of training groups into units of the most effective instructional size (*c* below).

*b.* The step-by-step method is the most effective one for instructing in drill and ceremonies. The steps are as follows:

- (1) Give the name of the movement and its practical use to the individual or unit.
- (2) Give the command to be used for the movement and explain its elements: the preparatory command and the command of execution (par. 7).
- (3) Explain the movement so that soldiers may understand its pertinent points.
- (4) Demonstrate the movement. If it has two or more counts, the demonstrators execute it by the numbers (par. 5), one count or movement at a time and in the cadence (quick time, double time) in which it is to be executed. If the movement is not a precision movement, the demonstrators are talked through each part of it to acquaint soldiers with the pertinent points to be practiced.
- (5) Give practical work by the numbers, or talk through the movement and follow this by having the movement executed at normal cadence. Instructors and assistant instructors supervise each movement closely and have them repeated until precision becomes habitual.

*c.* Instruction and practical work in all phases of the manual of arms and in the first six paragraphs of the school of the soldier without arms are most effectively presented in the **U** formation. In this formation, three squads are formed, each in line, one to the front and one on each side of the instructor. If a fourth squad is present, it forms behind and uncovers the squad that is to the instructor's front.

*d.* Instruction and practical work in all phases of squad drill are most effectively presented in training groups of squad size. Instruction in platoon drill is best explained and demonstrated by a training group of platoon size. The practical work in platoon drill is executed by the platoon as a unit. The practical work in units larger than a platoon is most effectively conducted when the organized elements of the unit are left intact for drill purposes rather than being arbitrarily broken down into training groups of any given size.

*e.* Officers, noncommissioned officers, guidon bearers, and special units occupy designated posts in the various formations or units. When changes of formations involve changes of posts, the new posts are taken by the most direct route, except when otherwise prescribed, and should be taken as soon as practicable after the command of execution for the movement. Officers and noncommissioned officers who have prescribed duties in connection with the movement take their posts when such duties are completed. When executing any facing movement, alining units, or when moving from one post to another, officers and noncommissioned officers maintain a military bearing and move with precision.



*f.* When a noncommissioned officer takes the place of an officer in commanding a unit, or an element of a larger unit, he occupies the same post as prescribed for the officer. He then carries his rifle at sling arms, as does an officer who is armed with a carbine. At all other times when giving commands, making reports, or drilling a unit, a non-commissioned officer, except a squad leader in ranks, carries the rifle at right shoulder arms.

*g.* When acting as instructors, officers and non-commissioned officers go wherever their presence is necessary. They correct mistakes and insure steadiness and proper performance in ranks. When an individual shows clearly that he is unable to execute the proper movements or assume the proper position, the instructor may use his hands to assist him.

## **5. Additional Techniques for Drill Instruction**

*a.* *By the numbers* is the method by which precision movements of two or more counts are demonstrated, practiced, and learned, one count at a time. This method enables the soldier to learn step by step and permits the instructor to make detailed corrections. The instructor commands **BY THE NUMBERS** before giving the commands for the movements. (**BY THE NUMBERS, ABOUT, FACE.**) The first count of the movement is executed on the command of execution, **FACE**. The second count is executed on command, **TWO** of **READY, TWO**; etc.

*b.* *All subsequent commands* are executed by the numbers until the command **WITHOUT THE NUMBERS** is given. For example, in teaching right and left face, the command **BY THE NUMBERS** would be given at the beginning of the practical exercise. Each

facing is repeated several times by the numbers until the instructor gives WITHOUT THE NUMBERS. The same exercises are repeated in the cadence (par. 13) for the movement. Subsequent movements are also executed in the cadence for the movement.

*c. Talking through a movement* is the method by which an exercise containing several nonprecision movements is demonstrated, practiced, and learned. Each movement is executed as it is described. In FIX BAYONETS, for example, the instructor tells the soldier to move the muzzle of the rifle to the left and grasp it below the stacking swivel with his left hand. After the soldier executes these steps, the instructor tells him to grasp the bayonet in his right hand. After talking the soldier through the remaining steps, the instructor has him practice the movement in normal cadence.

*d. Oral examinations* are given soldiers at regular intervals throughout their training in drill and ceremonies. These examinations are given with the minimum number of students per instructor. Each soldier is required to give instruction to other members of his group as if they had no previous knowledge of the subject. The instructor rates the soldiers for instructional ability and technical knowledge. The group of soldiers will find that they increase their grasp of the subject and teach themselves by the repetition required in the examination.

*e. Competitive drill exercises* are conducted to determine the best drilled individual and unit within larger units. Appropriate prizes are awarded at ceremonies to the winners in this competition.

## 6. Command Voice

Instructors should pay particular attention to developing command voice in soldiers. This can be done by—

*a.* Setting the example; that is, by giving all commands to soldiers with the correct voice control, distinctness, inflection, cadence, and snap (pars. 9–14).

*b.* Encouraging the members of an instructional group to practice commands with the help of the instructors.

*c.* Giving the members of an instructional group the opportunity to command.

## CHAPTER 2

# COMMANDS AND THE COMMAND VOICE

---

### Section I. COMMANDS

#### 7. General

A drill command is an oral order of a commander. The commander gives all commands to his unit, except in the few cases mentioned in this manual.

a. Most drill commands have *two parts*, known as the *preparatory command* and the *command of execution*. Neither of these parts is actually a command by itself, but they are termed commands to simplify instruction.

(1) *The preparatory command* states the movement or formation to be carried out and mentally prepares the individual for its execution. In the command FORWARD, MARCH, the preparatory command is FORWARD.

(2) *The command of execution* tells when the movement is to be carried out. In FORWARD, MARCH, the command of execution is MARCH.

b. In some commands, the preparatory command and the command of execution are combined, for example: FALL IN, CONTINUE THE MARCH, CLOSE ON LEADING PLATOON, AT EASE, and REST. These commands are given *without in-*

*flection* and at a uniformly high pitch and loudness comparable to that for a normal command of execution.

*c.* The commander faces his troops when giving commands except as outlined in paragraph 8*c*.

*d.* For a change in direction, the preparatory command and the command of execution are given so as to end as the foot corresponding to the direction of the turn or movement strikes the ground.

*e.* The commander gives AS YOU WERE to revoke a preparatory command *that he has given*. He may give AS YOU WERE to cancel a command of execution for facing movements or movements in the manual of arms that are being improperly executed. In this case, the movement stops and the men resume their former position. If an improperly given command is not revoked, the men execute the movement in the best manner possible.

## **8. Supplementary Commands**

*a.* When a command requires an element of a unit to execute a movement different from the other elements, or the same movement at a different time, the subordinate commander gives a *supplementary command* over his shoulder.

*b.* Generally, supplementary commands are given between the preparatory command and command of execution of the unit commander. In some cases, the supplementary commands follow the command of execution.

*c.* When a subordinate leader gives a *supplementary command*, he turns his head toward the majority of his element and gives the command over his shoulder. He does not face about.

## Section II. THE COMMAND VOICE

### 9. General

The precision with which a movement is executed is affected by the manner in which the command is given. A correctly delivered command is loud and distinct and will be understood clearly by everyone in the unit. Correct commands have a tone, cadence, and snap that demand willing, correct, and immediate response.

### 10. Voice Control

*a.* The loudness of a command is adjusted to the number of men in the unit. Normally, the commander places himself in the front and center of his unit and speaks facing his unit so that his voice reaches all the men.

*b.* It is necessary for the voice to have carrying power, but excessive exertion is unnecessary and harmful. A typical result of "trying too hard" is the almost unconscious tightening of the neck muscles to force out sound. This will produce strain, hoarseness, sore throat, and, worst of all, indistinct and jumbled sounds instead of clear commands. Ease is achieved through good posture, proper breathing, correct adjustment of throat and mouth muscles, and confidence.

*c.* The best posture for giving commands is at the position of attention (fig. 6). Soldiers in formation notice the posture of their leader. If his posture is unmilitary (relaxed, slouched, stiff, or uneasy) the men will imitate it.

*d.* The most important muscle used in breathing is the diaphragm—the large muscle that separates the

chest cavity from the abdominal cavity. The diaphragm automatically controls normal breathing and is used to control the breath in giving commands.

e. The cavities of the throat, mouth, and nose act as amplifiers and help to give fullness (*resonance*) and *projection* to the voice.

## 11. Distinctness

a. Distinctness depends on the correct use of your tongue, lips, and teeth, which form the separate sounds of a word and group the sounds into syllables. Distinct commands are effective; indistinct commands cause confusion. All commands can be pronounced correctly without loss of effect. Place emphasis on correct enunciation (distinctness). To enunciate clearly, make full use of your lips, tongue, and lower jaw.

b. To develop the ability to give clear, distinct commands, practice giving commands slowly and carefully, prolonging the syllables. Then gradually increase your rate of delivery until you develop the proper cadence, still enunciating each syllable distinctly.

## 12. Inflection

Inflection is the rise and fall in pitch and the tone changes of the voice.

a. *The preparatory command* is the command which indicates the movement. Pronounce each preparatory command with a generally rising inflection. The most desirable pitch when beginning a preparatory command is near the level of your natural speaking voice. A common fault with begin-

ners is to start the preparatory command in a pitch so high that, after employing a rising inflection for the preparatory command, it is impossible to give the command of execution with clarity or without strain. *A good rule to remember is to begin a command near the natural pitch of your voice.*

*b. The command of execution* is the command which indicates when a movement is to be executed. Give it in a sharper tone and in a slightly higher pitch than the last syllable of the preparatory command. It must have plenty of snap. The best way to develop a command voice is to practice commands like PLATOON, HALT. Figures 1 through 5 show graphically how commands should sound and how they should be given.

*c. In some commands* such as FALL IN and FALL OUT, the preparatory command and command of execution are combined. Give these commands *without inflection* and at a uniformly high pitch and loudness comparable to that for a normal command of execution.

### **13. Cadence**

*a. Cadence* in commands means a uniform and rhythmic flow of words. The interval between commands is generally of uniform length for any given troop unit. This is necessary so that everyone in the unit will be able to understand the preparatory command and will know when to expect the command of execution. For the squad or platoon in march, except when supplementary commands need to be given, the best interval of time is that which allows one



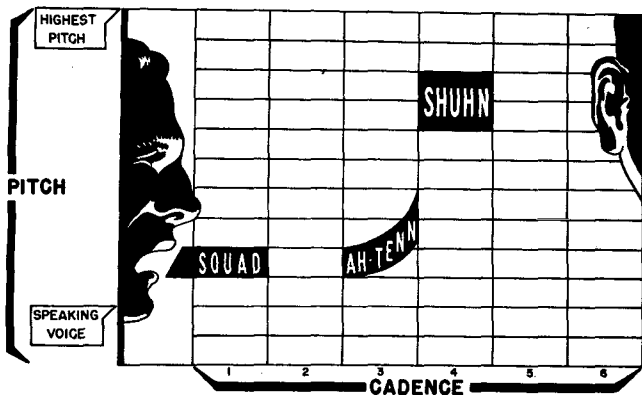

Figure 1. Diagram of the command, *SQUAD, ATTENTION*.

step to be taken between the preparatory command and the command of execution. For example:

ONE	TWO	THREE
PLATOON		HALT

The same interval is best for commands given at the halt. To develop the proper cadence, count the cadence *ONE, TWO, THREE, FOUR*, in quick time; then give commands such as *RIGHT, FACE*, without interrupting the cadence:

ONE	TWO	THREE	FOUR
RIGHT		FACE	

Longer commands, such as *RIGHT FLANK, MARCH*, must be started so that the preparatory command will end on the proper foot, and leave a full count between the preparatory command and command of execution:

LEFT		RIGHT	LEFT	RIGHT
	$\frac{1}{2}$	RIGHT FLANK		MARCH

Pronounce each word distinctly.

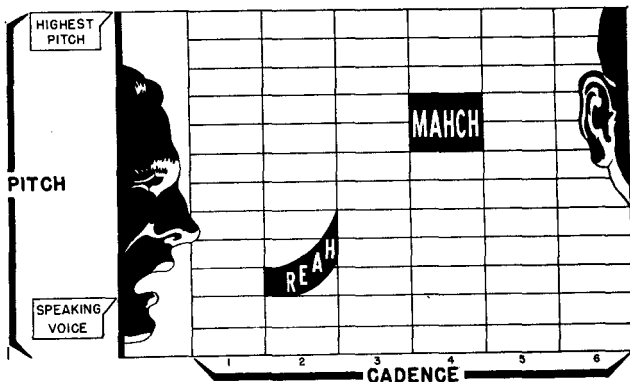

Figure 2. Diagram of the command, REAR, MARCH.

b. For a platoon, company, or larger unit, when supplementary commands are necessary, the interval must be long enough to let the other leaders give their preparatory commands or to give the supplementary command for their particular unit. The following example shows proper cadence for giving the command RIGHT, FACE, to a company in line or a column of platoons.

ONE	TWO	THREE	FOUR	ONE	TWO
RIGHT		RIGHT		FACE	
(Company		(Platoon		(Company	
Commander)		Leaders)		Commander)	

#### 14. Snap

*Snap* is that extra quality in a command that demands immediate response. It expresses confidence, alertness, and decisiveness—complete control of yourself and situation. Get as much *snap* into the commands as possible, but never neglect *distinctness*. Know the commands and be able to voice them effectively.

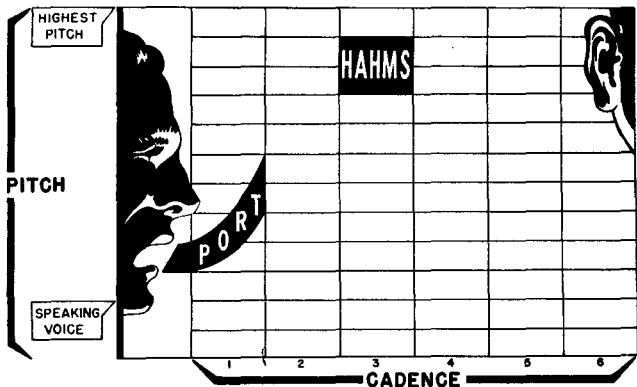

Figure 3. Diagram of the command, PORT, ARMS.

## 15. Mass Commands

a. Mass commands may be used to develop confidence and enthusiasm. All members of the unit being trained speak the commands in unison and execute them.

b. When the instructor wants his unit to use mass commands, he announces AT YOUR COMMAND. He gives a preparatory command describing the movement he wants performed; for example, FACE THE PLATOON TO THE RIGHT. His command of execution is COMMAND. When he says COMMAND, all men in the unit give the command RIGHT, FACE in unison and execute it.

c. The following mass commands are the ones normally used:

- (1) CALL THE PLATOON TO ATTENTION, COMMAND.
- (2) HAVE THE PLATOON STAND AT PARADE REST, COMMAND.

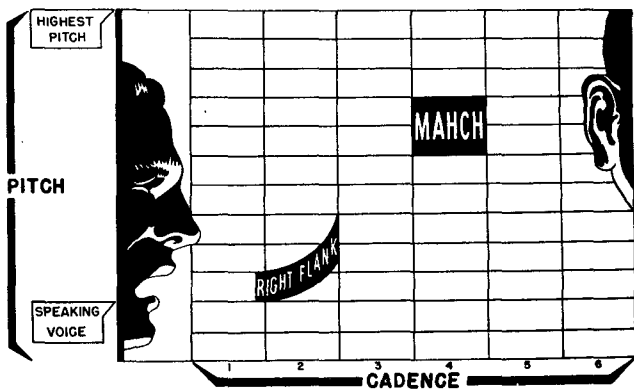

Figure 4. Diagram of the command, *RIGHT FLANK, MARCH.*

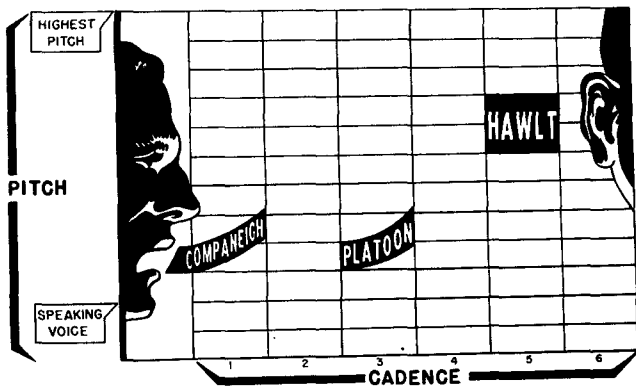

Figure 5. Diagram of the command, *COMPANY (PLATOON), HALT.*

(3) FACE THE PLATOON TO THE RIGHT, COMMAND.

(4) MARCH THE PLATOON FORWARD, COMMAND.

(5) HALT THE PLATOON, COMMAND.

*d.* To give mass commands while marching, the instructor gives the preparatory command for the movement and substitutes COMMAND for the command of execution MARCH; for example: COLUMN RIGHT, COMMAND; REAR, COMMAND; etc.

*e.* When the instructor wants to stop mass commands, he says AT MY COMMAND. The normal method of drilling is then resumed.

## **16. Individual Commands From Ranks**

After a unit has acquired some skill in executing commands and in giving mass commands, the instructor may designate an individual by name or place in ranks and have him give commands. He designates the man while marching or at a halt and describes the movement to be performed as he does for mass commands, except that he does not add COMMAND. The designated man then gives the appropriate command, remaining in his position in ranks and executing the movement with the platoon. After the man has given several commands, the instructor and the rest of the group critique his performance.

## CHAPTER 3

### SCHOOL OF THE SOLDIER WITHOUT ARMS

---

#### 17. General

*a.* This chapter contains most of the individual positions and movements required in drill. These positions and the correct execution of the movements in every detail should be learned before proceeding to unit drill. Absolute precision is required in drills.

*b.* The explanation of a movement that may be executed toward either flank is given in this chapter for only one flank. To execute the movements toward the opposite flank, substitute the word "left" for "right," or "right" for "left" in the explanation.

*c.* Any marching movement may be executed in double time unless stated otherwise. When a movement is to be executed in double time from a halt or from quick time, the command **DOUBLE TIME** immediately precedes the command of execution. (When the unit is in double time, **DOUBLE TIME** is not given preceding the command of execution for the movement.)

#### 18. Definitions

To help understand the meaning of certain terms used in this chapter, the following definitions are included:

*a.* *Cadence* is the uniform rhythm in which a movement is executed, or the number of steps or

counts per minute at which the movement is executed.

*b. Double time* is the cadence of 180 counts or steps per minute. It is also the name of the marching movement in which 180 36-inch steps per minute are taken.

*c. Element* is an individual, squad, section, platoon, company, or larger unit forming a part of the next larger unit.

*d. Step* is the prescribed distance measured from heel to heel of a marching man.

*e. Quick time* is the cadence of 120 counts or steps per minute. It is also the name of the marching movement in which 120 30-inch steps per minute are taken.

## **19. Position of Attention**

*a.* Assume the position of attention (fig. 6) on the command **FALL IN** or **SQUAD (PLATOON), ATTENTION**.

*b.* To come to attention, bring your heels together smartly on the same line.

*c.* Turn your feet out equally, forming an angle of 45°.

*d.* Keep your legs straight without stiffening or locking your knees.

*e.* Hold your body erect with your hips level, chest lifted and arched, and your shoulders square and even.

*f.* Let your arms hang straight without stiffness along your sides with the backs of your hands outward, your fingers curled so that the tips of your thumbs touch the tips of your forefingers. Keep your thumbs along the seams of your trousers.



*Figure 6. Position of attention.*



*g.* Keep your head erect and hold it squarely to the front with your chin drawn in so that the axis of your head and neck is vertical. Look straight to the front.

*h.* Rest the weight of your body equally on the heels and the balls of your feet.

## **20. Rests at the Halt**

*a.* The following rests are executed at the halt: *parade rest, stand at ease, at ease, rest,* and *fall out.*

*b.* At the command REST, of PARADE, REST (given at attention only), move your left foot smartly 12 inches to the left of your right foot. Keep your legs straight so that the weight of your body rests equally on the heels and the balls of your feet (fig. 7). At the same time, let your arms hang behind your back with your hands just below the belt line. Keep the fingers of both hands extended and joined, interlocking your thumbs so that the palm of your right hand is outward (fig. 8). Hold your head and eyes as at the position of attention. Remain silent and do not move.

*c.* At the command EASE, of STAND AT, EASE (given from the position of attention), execute parade rest as described above, but turn your head and eyes directly toward the commander. This command is given to gain the undivided attention of the unit when it is in a rest position, without sacrificing a uniform appearance.

*d.* At the command AT EASE, keep your right foot in place. You may move, but must remain silent.

*e.* At the command REST, keep your right foot in place. You may talk and move.

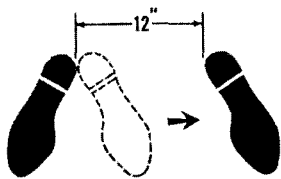
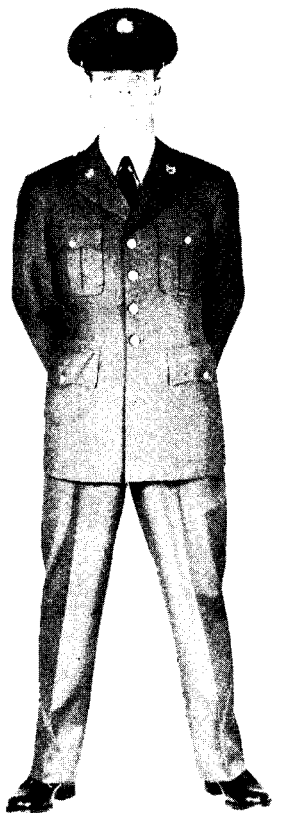

*Figure 7. Parade rest (front view).*

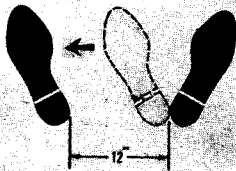
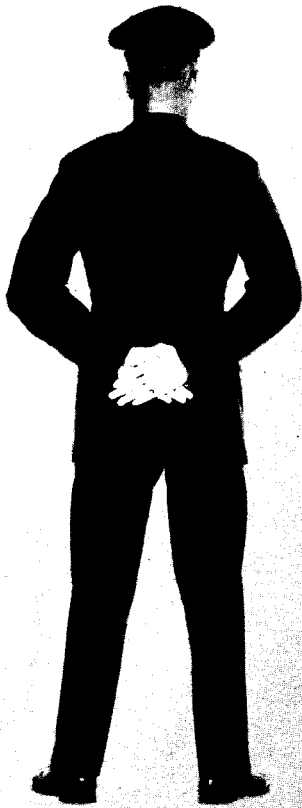

*Figure 8. Parade rest (rear view).*

*f.* AT EASE and REST may be commanded from the position of attention, from each other, from parade rest, or stand at ease.

*g.* In resuming the position of attention from at ease, stand at ease, or rest, take the position of parade rest at the command SQUAD or PLATOON; at the command ATTENTION, assume that position.

*h.* At the command FALL OUT, given from attention only, you may leave your position in the formation, but remain in the immediate area. Resume your former place in the formation at the position of attention at the command FALL IN.

## 21. **Facings at the Halt**

Facings at the halt are executed in quick time.

*a. Face to the Flank.* The command is RIGHT (LEFT), FACE. This is a 2-count movement. At the command FACE, slightly raise your left heel and right toe, and turn 90° to the right on your right heel, assisted by a slight pressure on the ball of your left foot, in one count. Hold your left leg straight without stiffness (1, fig. 9). On the second count, place your left foot smartly beside your right foot, as at attention (2, fig. 9). Hold your arms as at attention when executing this movement.

*b. Face to the Rear.* The command is ABOUT FACE. This is a 2-count movement. At the command FACE, move the toe of your right foot to a position touching the ground one-half the length of your foot to the rear and slightly to the left of your left heel. This is the first count of the movement (1, fig. 10). Do not change the position of your left foot and keep your right leg straight without stiff-

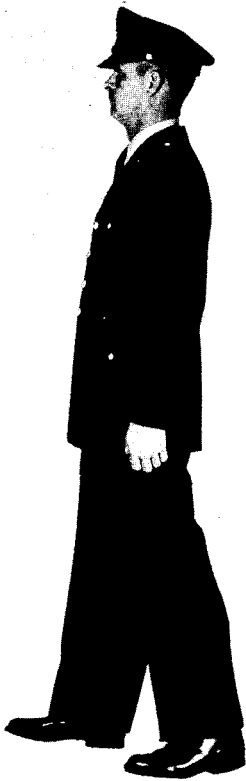

①

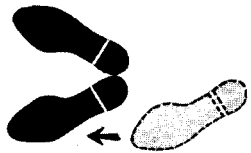

②

Figure 9. Right face.

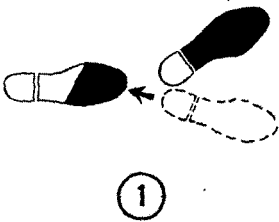
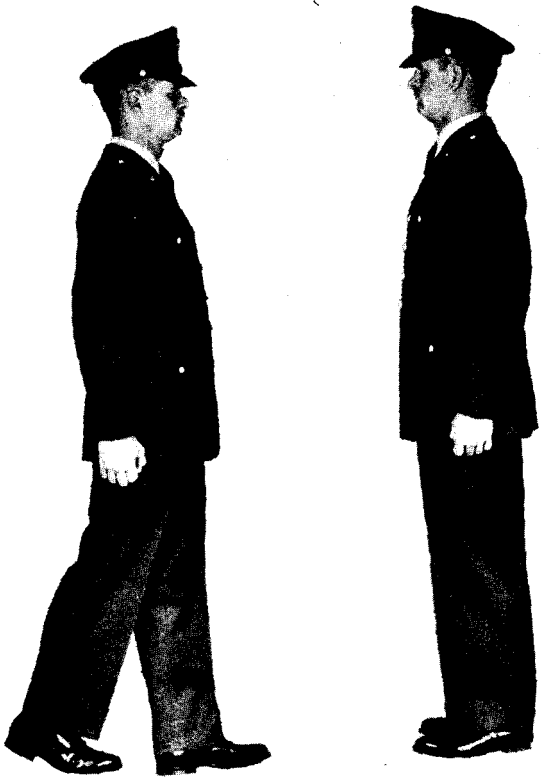

Figure 10. About face.

ness, resting most of the weight of your body on the heel of the left foot. On the second count, face to the rear, turning 180° to the right on your left heel and the ball of your right foot so that your feet are as at attention when you complete the turn (2, fig. 10). Hold your arms as at attention when executing this movement.

## 22. Hand Salute and Eyes Right

*a.* For instructional purposes, the command is **HAND, SALUTE**. This is a *2-count* movement. On the *first* count, raise your right hand and arm smartly, in the most direct manner, until the tip of your forefinger touches the lower part of your headdress. When not wearing a headdress, touch your forehead slightly above your right eye. Keep your fingers and thumb extended and joined, your forearm, wrist, and hand straight, and your upper arm horizontal (fig. 11). On the *second count* (**READY, TWO**), drop your hand and arm smartly in the most direct manner to your side as in the position of attention.

*b.* **EYES, RIGHT** is a *1-count* movement. On the command **RIGHT**, turn your head and eyes smartly to the right at an angle of 45°, keeping your shoulders parallel to the front. On the command **FRONT** or **READY, FRONT**, turn your head and eyes smartly to the front.

## 23. Steps and Marchings

*a.* When executed from a halt, all steps and marchings except right step begin with the left foot.

*b.* For movements involving a turn while marching, both the preparatory command and the com-



①



②

*Figure 11. Hand salute.*



mand of execution are completed on the foot in the direction of the turn. For units no larger than a squad or platoon, the commands are given so that there is one step between the end of the preparatory command and the command of execution. For units larger than a platoon, time is allowed for the unit leaders to repeat the preparatory command or give their supplementary command.

*c.* When instructing in marching, it is often helpful to have the soldiers count cadence. The instructor should count cadence as little as possible. The command **COUNT CADENCE, COUNT**, is given as the left foot strikes the ground while marching at quick or double time. The soldiers take one more step and then count aloud for eight steps: **ONE, TWO, THREE, FOUR, ONE, TWO, THREE, FOUR**. The count should be vigorous and snappy. When the unit is further along in its training, it should be halted when necessary and marched forward again to get proper cadence. The soldiers should develop a sense of rhythm rather than depend upon counting cadence.

#### **24. To March With a 30-inch Step**

*a.* Being at the halt, to march with a 30-inch step in the cadence of quick time, the command is **FORWARD, MARCH**. At the command **FORWARD**, shift the weight of your body to your right leg without noticeable movement. At the command **MARCH**, step off smartly with your left foot and march straight forward with 30-inch steps without stiffness or exaggerating your movements. Swing your arms easily in their natural arcs, 9 inches straight

to the front and 6 inches to the rear of the seams of your trousers. Keep your arms straight without stiffness, your fingers curled as in the position of attention and just clearing your trousers when swinging.

*b.* To halt from quick time, the command is SQUAD (PLATOON), HALT, given as either foot strikes the ground. At the command of execution, take one more step and then bring your rear foot alongside the stationary foot, as as the position of attention, halting in two counts.

## **25. To March With a 15-Inch Step (Half Step)**

*a.* To march with a 15-inch step, the command HALF STEP, MARCH is given on either foot, and only while marching at quick time.

*b.* At the command MARCH, take one more 30-inch step, then take 15-inch steps in the cadence of quick time. Allow your arms to swing naturally.

*c.* To resume the 30-inch step, the command FORWARD, MARCH is given as either foot strikes the ground. At the command of execution, take one more 15-inch step and then step off with a full 30-inch step.

*d.* The halt from the half step is similar to the halt from quick time.

*e.* While marching at the half step, *mark time march*, *forward march*, and *halt* are the only commands that may be given.

## **26. To March in Place**

*a.* To march in place at quick time, the command MARK TIME, MARCH is given as either foot strikes

the ground while marching at quick time or at half step.

*b.* When marching at quick time or half step and the command MARK TIME, MARCH is given, take one more step after the command of execution, plant the trailing foot alongside your stationary foot and march in place. Raise each foot alternately, approximately 2 inches off the ground, executing the movement in quick time. Allow your arms to swing naturally.

*c.* The command FORWARD, MARCH is given to resume marching with the 30-inch step. Take one more step in place and then step off with a full step. This command is given as either foot strikes the ground.

*d.* The halt from mark time is executed similarly to the halt from quick time.

## **27. To March With a 12-inch Step**

*a.* The command RIGHT (LEFT) STEP, MARCH is given only from the halt.

*b.* On the command MARCH, slightly bend your *right* knee and raise your *right* leg only high enough to allow freedom of movement. Place your *right* foot 12 inches to the *right* of the *left* foot, and then move the *left* foot, keeping your *left* leg straight, to a position alongside the *right* foot as in the position of attention. Continue this movement in the cadence of quick time, keeping your arms by your sides, until the command HALT is given.

*c.* To *halt* from the right (left) step, the preparatory command is given when the heels are together, and the command of execution (HALT) when the heels are together the next time. The halt

from the right (left) step is executed in two counts. On the command **HALT**, take one more step with your right foot and place your left foot alongside the right, in the position of attention.

### **28. To March Backward With a 15-Inch Step**

*a.* The command **BACKWARD, MARCH** is given from the halt, and for short distances only.

*b.* At the command **MARCH**, take a 15-inch step backward with your left foot and continue marching backward with 15-inch steps in the cadence of quick time only, allowing your arms to swing naturally.

*c.* **HALT** from backward march is executed in two counts, similarly to the halt from quick time, and may be given as either foot strikes the ground.

### **29. To March in the Opposite Direction**

*a.* The command **REAR, MARCH** is given as the right foot strikes the ground and only while marching in quick time.

*b.* At the command of execution, take one more step with your left foot, pivot on the balls of both feet, turning 180° to the right, and step off in the new direction. The pivot takes a full count. Hold your arms at your sides while executing the movement.

### **30. To Change Step**

*a.* The command **CHANGE STEP, MARCH** is given as the right foot strikes the ground while marching at quick time.

*b.* At the command of execution, take one more step with your left foot, then in one count, place

your right toe near the heel of your left foot and step off again with your left foot.

### **31. To Face in Marching From a Halt**

Facings in marching from a halt are important parts of the following movements: alinements; column left; close and extend while in line; take interval; and assemble. *For instructional purposes only*, the command FACE TO THE RIGHT (LEFT) IN MARCHING, MARCH may be used to *teach the individual to execute the movement properly*. To execute the movement, pivot to the right or left on the ball of your *right* foot, and step off in the indicated direction with your *left* foot. Execute the pivot and the step in one count and continue marching in the new direction.

### **32. To March With a 36-inch Step (Double Time)**

*a.* The command DOUBLE TIME, MARCH is given from a halt, or as either foot strikes the ground while marching at quick time.

*b.* When double time is given from a halt, shift the weight of your body to your right leg without noticeable movement. At the command MARCH, raise your forearms to a horizontal position, with your fingers and thumbs closed, knuckles out, and step off with your left foot. Continue to march with 36-inch steps in an easy jog at the cadence of double time. Let your arms swing naturally, straight to the front and rear, but keep your forearms horizontal.

*c.* When marching at quick time, and the command DOUBLE TIME, MARCH is given, take one more 30-inch step and step off with your trailing foot in double time as instructed in *b* above.

*d.* To resume quick time from double time, the command is QUICK TIME, MARCH, given as either foot strikes the ground. At the command of execution, take two more double time steps, then resume quick time, dropping your arms to your sides.

*e.* To halt from marching at double time: at the command of execution, HALT, take two more double time steps, then drop your arms and halt in two counts in the cadence of quick time.

### **33. To March at Double Time in Place**

*a.* To march at double time in place, the command IN PLACE DOUBLE TIME, MARCH is given only from a halt.

*b.* On the preparatory command IN PLACE DOUBLE TIME, shift the weight of your body to your right leg without noticeable movement. On the command MARCH, raise your forearms to a horizontal position with your fingers and thumbs closed, knuckles out and (at the same time) starting with your left foot, raise your feet alternately approximately 6 inches off the ground in the cadence of double time.

*c.* To halt from in place double time, the command of execution is given as either foot strikes the ground. Take two more steps in double time, then halt in two counts.

### **34. Rest Movements While Marching**

*a.* The commands AT EASE, MARCH or ROUTE STEP, MARCH, are given on either foot when marching at quick time.

*b.* At the command MARCH of AT EASE, MARCH, take one more step and assume AT EASE, MARCH.

Cadence is not required, but silence is maintained, as is the prescribed interval and distance.

*c.* At the command **MARCH** of **ROUTE STEP, MARCH**, take one more step and assume **ROUTE STEP, MARCH**. Neither silence nor cadence is required, but the prescribed interval and distance are maintained.

*d.* The commands **AT EASE** and **ROUTE STEP, MARCH** are given only from quick time or from each other. The unit must be called to attention before other commands may be given. The commander counts cadence for eight steps after calling the unit to attention.

## CHAPTER 4

### SCHOOL OF THE SOLDIER WITH ARMS

---

#### Section I. MANUAL OF ARMS FOR THE RIFLE

##### 35. General

*a.* Execute FALL IN with the rifle at order arms.

*b.* Facings, alinements, and short-distance marching movements are normally executed from order arms. Right (left) step, backward march, open and close ranks, and close and extend are short-distance movements. To march units forward for similar short distances, forward march may be given from order arms. When these movements are commanded while at order arms, come automatically to trail arms on the command of execution for the movement. Return the rifle to order arms on halting.

*c.* Before starting any other marching movement of armed troops, face the troops in the desired direction of march and then bring the weapons to right shoulder, port, or sling arms by the appropriate command. When a marching movement has been completed, and it is desired to execute a facing movement, first have the weapon brought to order arms or unsling arms and then give the command for the facing movement.

*d.* When at a position other than sling arms, come to port arms for double time. When in formation, the commander gives the appropriate commands.



### 36. Rules for the Rifle Manual of Arms

a. The term "at the balance" refers to a point on the rifle just forward of the trigger housing (fig. 12).

b. With your left hand at the balance, hold the rifle with your thumb and fingers, including the sling in your grasp. Extend and join your fingers, forming a **U** with your thumb.

c. The position of the rifle known as "diagonally across the body" is as follows (fig. 13): the barrel is up, the heel of the butt is on line with your right hip, and the barrel is at such an angle that one point of the barrel is in front of the juncture of your neck and left shoulder. Hold the rifle at a height which allows your right forearm to be horizontal when you grasp the small of the stock with your right hand. Grasp the rifle at the balance with your left hand as described in *b* above, keeping your left elbow at your side. The distance of the rifle from your body depends upon the conformation of your body, but it should be approximately 4 inches from your belt.

d. The cadence for rifle movements is quick time; however, in early stages of instruction, precise execution is learned before acquiring the proper cadence.

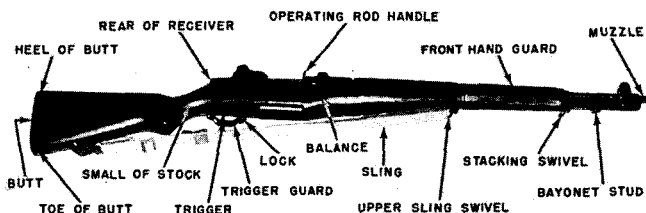

Figure 12. Drill nomenclature of the U. S. rifle, cal. .30, M1.



*Figure 13. Rifle held diagonally across the body.*

*e.* The manual for the rifle is taught to be executed while standing at the position of attention. To add interest to drill or lessen fatigue on long marches, movements between right and left shoulder, and port arms may be commanded when marching at attention in quick time. To move the rifle to the left shoulder from the right shoulder when marching, the command **LEFT SHOULDER, ARMS** is given as the left foot strikes the ground. The first count of this movement is executed as the right foot strikes the ground and the left arm is moving forward in its natural arc. To move the rifle to the right shoulder from the left shoulder while marching, the command **RIGHT SHOULDER, ARMS** is given as the right foot strikes the ground. The first count of this movement is executed as the left foot strikes the ground and the right arm is moving forward in its natural arc.

*f.* Any position of the manual of arms may be executed from another position, except inspection arms, trail arms, sling and unsling arms, and fix and unfix bayonets, which must be executed from the position of order arms. Port arms is the only movement that may be commanded from inspection arms.

### **37. Order Arms**

*a.* Order arms is the position of the soldier at attention with the rifle. It is assumed on the command **SQUAD (PLATOON), ATTENTION** from any of the rest positions except fall out. Order arms is assumed on the command **FALL IN** and on the command **ORDER, ARMS** from any position in the manual except inspection arms and sling arms.

*b.* At order arms, maintain the position of attention except for your right arm and rifle. Place the butt of the rifle on the ground with the barrel to the rear and the toe of the rifle butt against your right shoe, on line with the front of your right shoe. Grasp the front hand guard with your right hand in a **V** formed by your fingers extended and joined, and your thumb. Hold the tips of your index finger and thumb on line with the forward edge of the front hand guard. Keep your right hand and arm behind the rifle so that your thumb is along your trousers seam (fig. 14).

### **38. Rest Positions With the Rifle**

The rest positions with the rifle are commanded and executed as without arms, with the following exceptions and additions.

*a.* On the command **PARADE, REST**, keep the toe of the rifle butt on line with the front of your right shoe, and hold the rifle butt against your right shoe. Slide your right hand upward, regrasp the front hand guard just below the stacking swivel and straighten your right arm so the muzzle of the rifle is inclined straight to the front. Place your left hand behind your back, just below the belt line, with your fingers and thumb extended and joined and your palm to the rear. Thrust the rifle out at the same time you move your left foot (fig. 15).

*b.* Execute **STAND AT, EASE**, with the rifle, the same as parade rest with the rifle, but turn your head and eyes toward the commander.

*c.* On the command **AT EASE OR REST**, keep your right foot in place. Hold the rifle as in parade rest, except that you may relax your arms slightly.

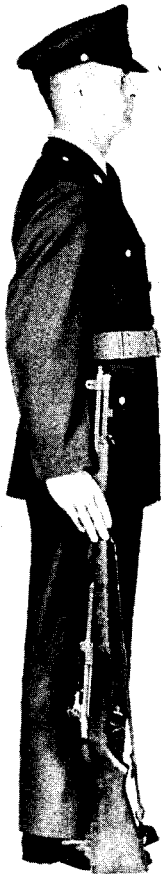

*Figure 14. Order arms.*

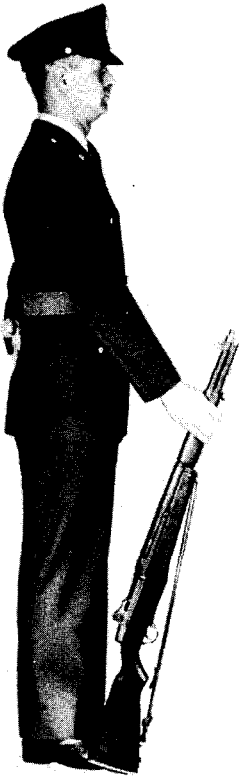

①

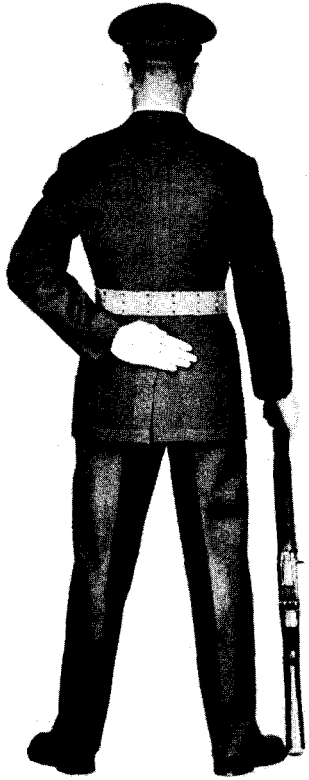

②

*Figure 15. Parade rest.*

When at sling arms, follow the procedure outlined in paragraph 46e.

d. Armed troops must be at attention at order arms, port arms, stack arms, or unsling arms before FALL OUT may be given.

### 39. Trail Arms

a. When at the position of order arms, the position of trail arms is executed on the command of execution of a march command when no other command precedes the preparatory command for the movement.

b. For instructional purposes, the command TRAIL, ARMS may be used to teach the position at a halt. At the command ARMS, grasp the rifle with your right hand, with your fingers and thumb closed around the front hand guard, your forearm and wrist straight, and your elbow into your side. Raise the rifle butt 3 inches off the ground and incline the rifle forward at an angle of  $30^{\circ}$ . This movement is executed in one count (fig. 16).

c. At the command ARMS, of ORDER, ARMS, lower the rifle to the ground with your right hand and resume the position of order arms. When TRAIL, ARMS is commanded, hold the rifle at the trail until ORDER, ARMS is given.

### 40. Port Arms

a. The command is PORT, ARMS.

b. This is a 2-count movement from order arms. At the command ARMS, raise the rifle diagonally across the body with the right hand, grasping the balance with the left hand so that the rifle is approximately 4 inches from the belt. Hold your right elbow down without strain (1, fig. 17). On the *second*



*Figure 16. Trail arms.*



count, regrasp the rifle with your right hand at the small of the stock, fingers and thumb closed around the stock (2, fig. 17). At port arms, keep your right forearm horizontal with your elbows in at your sides and hold the rifle diagonally across the body, approximately 4 inches from your belt.

*c.* Order arms from port arms is executed in *three* counts. At the command ARMS, move your right hand up and across your body and grasp the front hand guard without moving the rifle (1, fig. 17). On the *second* count, release your left hand from the balance and lower the rifle to your right side with your right hand so that the butt is 3 inches from the ground. Place your left hand on the rifle in the vicinity of the stacking swivel, fingers and thumb extended and joined, palm to the rear, to steady the rifle and hold the barrel vertically (fig. 18). On the *third* count, lower the rifle gently to the order with your right hand and cut your left hand smartly to your side.

#### **41. Right Shoulder Arms**

*a.* The command is RIGHT SHOULDER, ARMS.

*b.* When executed from order arms, right shoulder arms is a *4-count* movement. At the command ARMS, execute the first count of port arms as described in 40*b* (1, fig. 19). Hold your right elbow down without strain. On the *second count*, regrasp the rifle at the butt with your right hand, the heel of the butt between the first two fingers and the thumb and fingers closed around the stock with the thumb and index finger touching (2, fig. 19). On the *third* count, place the rifle on your right shoulder with the grasp of your right hand unchanged. Re-

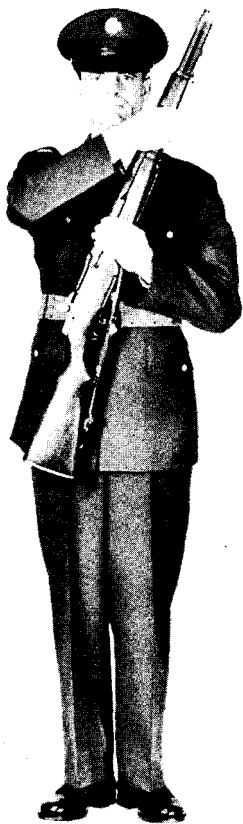

①



②

*Figure 17. Port arms.*



*Figure 18. Next to last count in executing order arms.*

lease your left hand from the balance and use it to guide the rifle to your shoulder by placing your left hand at the small of the stock, thumb and fingers extended and joined, palm toward your body, and the first joint of your left forefinger touching the rear of the receiver. Keep your left elbow down (3, fig. 19). On the *fourth* count, cut your left hand smartly back to its position by your side as at attention. At right shoulder arms, keep your right forearm horizontal and your right elbow against your side and on line with your back (4, fig. 19).

c. The return to order arms is a *4-count* movement. On the command ARMS, press the rifle butt down quickly and move the rifle diagonally across your body, turning the butt so as to keep the barrel up. Grasp the rifle smartly at the balance with your left hand, retaining the grasp of your right hand on the butt (count *one*). On the *second* count, move your right hand up and across your body and grasp the front hand guard. The *third* and *fourth* counts are executed in the same manner as the second and third counts in executing order arms from port arms (par. 40c).

d. Right shoulder arms from port arms is a *3-count* movement. On the *first* count, regrasp the rifle at the butt with your right hand as you would in coming to right shoulder from order arms. The last *two* counts are the same as the last two counts in moving from order to right shoulder arms.

e. Port arms from right shoulder arms is a *2-count* movement. The *first* count is the same as the first count from right shoulder to order arms. On the *second* count, regrasp the rifle with your right



①



②

*Figure 19. Right shoulder arms.*



3



4

*Figure 19—Continued.*

hand at the small of the stock in the position of port arms.

## **42. Left Shoulder Arms**

*a.* The command is LEFT SHOULDER, ARMS.

*b.* In coming to left shoulder from order arms, come to port arms in the first *two* counts (fig. 17). On the *third* count, place the rifle on your left shoulder with your right hand, keeping your right arm pressed against your body. At the same time, regrab the butt with your left hand in a manner similar to grasping the butt with your right hand in right shoulder arms (1, fig. 20). On the *fourth* count, cut your right hand smartly to your side as in the position of attention (2, fig. 20).

*c.* Port arms from left shoulder arms is a *2-count* movement. On the *first* count, move your right hand up and across the body and grasp the small of the stock with your right hand, keeping your right arm pressed against your body (1, fig. 20). On the second count, carry the rifle diagonally across your body with your right hand, and regrab the balance with your left hand as in the position of port arms (2, fig. 17).

*d.* Order arms or right shoulder arms from left shoulder arms is a *5-count* movement. On the first *two* counts, bring the rifle to port arms. On the last *three* counts, go to order arms or right shoulder arms as described in paragraphs 37 and 41.

## **43. Present Arms**

*a.* The command is PRESENT, ARMS.

*b.* Order arms to present arms is a *2-count* movement. On the *first* count, carry the rifle to the center



①



②

*Figure 20. Counts three and four of left shoulder arms from order arms.*



of your body with your right hand, keeping the barrel to the rear and vertical, right elbow down. Grasp the rifle and sling at the balance with your left hand, forearm horizontal, and elbow against your body (1, fig. 21). On the *second* count, grasp the small of the stock with your right hand (2, fig. 21). The distance of the rifle from your body depends upon the conformation of your body, but it should be approximately 4 inches from your belt.

*c.* Order arms from present arms is a *3-count* movement. Execute the *first* count by smartly grasping the rifle at the front hand guard with your right hand (fig. 21①), keeping your elbow down and at your side. On the *second* count, lower your rifle with your right hand, completing the *second* and *third* counts as in order arms from port arms (fig. 18).

*d.* Port arms from present arms is executed in *one* count. Raise and twist the rifle with your right hand, moving the muzzle to the left, and regrab the rifle at the balance with your left hand.

*e.* Present arms from port arms is executed in *one* count. Lower and twist the rifle with your right hand, moving the rifle to a vertical position, and regrab it at the balance with your left hand.

#### **44. Inspection Arms**

*a.* The command is INSPECTION, ARMS. Inspection arms is a *4-count* movement, and is executed only from the position of order arms.

*b.* The *first two* counts are the same as in going to port arms (1 and 2, fig. 17). On the *third* count, release your left hand from the balance and, with your fingers closed, palm in, forearm horizontal, place your



①

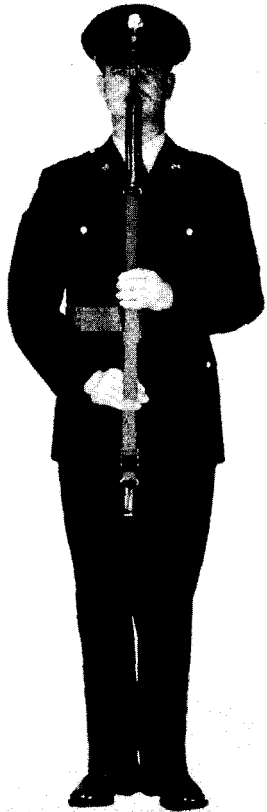

②

*Figure 21. Present arms.*

left thumb on the operating rod handle and push it smartly to the rear until it is caught by the operating rod catch. At the same time, lower your head and eyes enough to look into the receiver (fig. 22). On the *fourth* count, having found the receiver empty or having emptied it, raise your head and eyes to the front and at the same time regrasp the rifle at the balance with your left hand.

*c.* Port arms is the only command that may be given from inspection arms. On the preparatory command, with your fingers extended and joined, palm in, place the rear edge of your right hand against the operating rod handle and move it slightly to the rear. Then depress the follower with your right thumb and allow the bolt to move forward slightly, overriding the rear portion of the follower. At the command ARMS, remove your right thumb from the receiver and at the same time release the operating rod handle. Pull the trigger with your forefinger and regrasp the small of the stock in the position of port arms.

*d.* Inspection arms is executed when forming and dismissing the unit as a safety precaution.

#### **45. Rifle Salute**

*a.* This movement may be executed from order (fig. 23), trail, right shoulder arms (fig. 24), or left shoulder arms. For instructional purposes, the command RIFLE, SALUTE may be used. The rifle salute is a *2-count* movement.

*b.* When at order arms, on the *first* count, move your left arm across your body and with your forearm and wrist straight, fingers and thumb extended



*Figure 22. Third count of inspection arms.*

and joined, palm down, and touch the rifle with the first joint of your forefinger at a point between the stacking swivel and the muzzle (fig. 23). If not in ranks, turn your head and eyes toward the person or color saluted. On the *second* count, cut your left hand smartly away to your side and turn your head and eyes to the front.

*c.* When saluting at trail arms, the movements are identical with those for saluting at order arms. However, hold the rifle in the trail arms position.

*d.* At right shoulder arms, execute the movement by moving your left arm across your chest and touching the first joint of your forefinger to the rear of the receiver. Hold your left elbow so that the lower edge of your left forearm is horizontal. Hold your fingers, thumb, and wrist as described in *b* above, with your palm down (fig. 24). The *second* count of the rifle salute at right shoulder arms is similar to the return from the rifle salute at order arms.

*e.* At left shoulder arms, execute the movement by moving your right arm across your chest and touching the first joint of your forefinger to the rear of the receiver. Hold your right elbow so that the lower edge of your forearm is horizontal. Hold the fingers, thumb, and wrist as described in *b* above, with your palm down as in figure 24. The *second* count of the rifle salute at left shoulder arms is similar to the return from the rifle salute at right shoulder arms.

*f.* The next to the last count of right shoulder and order arms is not a rifle salute but is used for steadying the rifle. The rifle salutes are executed with



*Figure 23. Rifle salute at order arms.*



*Figure 24. Rifle salute at right shoulder arms.*

the palm of your hand down and the side of the first joint of your forefinger touching the rifle.

#### **46. Sling and Unslung Arms**

*a.* The command **SLING, ARMS** is given only from order arms. This movement is not executed in cadence. If the sling is not adjusted, at the command of execution, place the butt of the rifle on your right hip and cradle the rifle in the crook of your right arm. Adjust the sling with both hands and then sling the rifle on your right shoulder in the most convenient manner. When at sling arms, grasp the sling with your right hand, keep your right forearm horizontal, and hold the barrel of the rifle vertical (fig. 25). If the sling is already adjusted at the command **ARMS**, sling the rifle in the most convenient manner.

*b.* The command **UNSLING, ARMS** is given only from position of sling arms. At the command of execution, unslung the rifle and bring it to the position of unslung arms, steadying the rifle with your left hand. The positions of order arms and unslung arms are the same except that at unslung arms the sling is loose.

*c.* Before precise movements of the manual may be executed, the command **ADJUST, SLINGS** must be given. At the command **SLINGS**, tighten the sling from the position described in *a*, above.

*d.* To salute while at sling arms, on the command **ARMS**, or **PRESENT ARMS**, grasp the sling with your left hand to steady the rifle. Keep the palm of your left hand to the rear and forearm horizontal. At the same time release the sling with your right hand and execute the first count of hand salute, as described in



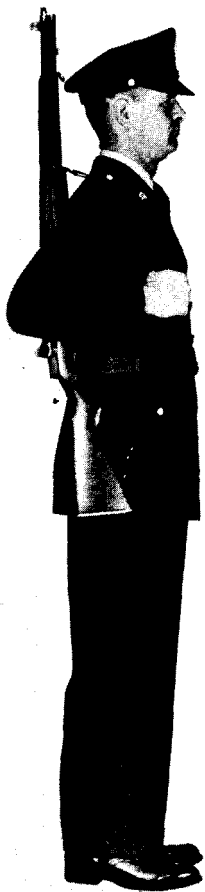

*Figure 25. Sling arms.*

paragraph 22. At the command **ARMS**, of **ORDER, ARMS**, move your right hand and arm smartly to your side as in the position of attention and then resume the original position of sling arms.

*e.* Execute parade rest and at ease while at sling arms in the manner prescribed for order arms, but keep the rifle slung, held with your right hand. When the command **REST** is given, you may unslung the rifle. At the preparatory command of **SQUAD** or **PLATOON**, take the position of parade rest at sling arms.

#### **47. Fix and Unfix Bayonets**

*a.* The command **FIX, BAYONETS** is given at order arms.

*b.* At the command **BAYONETS**, when the bayonet scabbard is on your belt, move the muzzle of the rifle to your left front and grasp the rifle at the front hand guard with your left hand. Then unfasten the snap on the scabbard and grasp the bayonet with your right hand, as shown in figure 26. Draw the bayonet from the scabbard. Glancing down, turn the point of the bayonet upward and fix the bayonet on the muzzle. Then resume the position of order arms.

*c.* The command **UNFIX, BAYONETS**, is given at order arms.

*d.* At the command **BAYONETS**, when the bayonet scabbard is on your belt, move the rifle to your left hand as when fixing bayonets. Glancing down, grasp the handle of the bayonet with your right hand and press the bayonet catch spring with the inside of your forefinger. Raise the bayonet vertically until the handle is about a foot above the muzzle of the

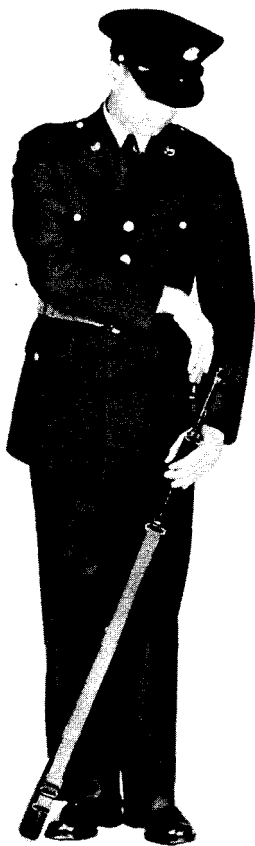

*Figure 26. Withdrawing or replacing the bayonet.*

rifle. Then, keeping your eyes on the bayonet point, drop the point to the left, turning the back of your hand toward your body, and return the bayonet to its scabbard. Resume the position of order arms and fasten the snap on the bayonet scabbard with your left hand.

*e.* When the bayonet is carried other than on the belt, fix and unfix bayonets in the most convenient manner upon receiving the commands.

*f.* The movements are not executed in cadence.

## **Section II. MANUAL OF ARMS FOR THE AUTOMATIC RIFLE**

### **48. General**

*a.* Except when otherwise prescribed, carry the automatic rifle slung over your right shoulder in a position similar to that prescribed for the rifle (fig. 25).

*b.* During marches and field exercises, when left shoulder arms is commanded to ease fatigue, change the automatic rifle to your left shoulder without cadence. Otherwise, remain at sling arms during the manual of arms, except for inspection arms when your unit is formed and dismissed.

*c.* When **AT EASE** is commanded, keep the automatic rifle slung unless otherwise ordered.

*d.* When **REST** is commanded, you may unsling the automatic rifle. When the preparatory command **SQUAD** or **PLATOON** is given, sling the automatic rifle and come to parade rest.

*e.* When **PARADE, REST** is commanded, keep the automatic rifle at sling arms. Execute the position as with the rifle (par. 46*e*).

f. When armed with the automatic rifle, give the hand salute as described in paragraph 46*d*.

#### **49. Inspection Arms**

a. **INSPECTION, ARMS** is commanded when at sling arms. At the command **ARMS**, grasp the magazine with your left hand and release the magazine catch with your right hand. Withdraw the magazine with your left hand and place it in your belt, open end down, the front of the magazine toward the right. Pull back the operating handle with your left hand to cock the piece and then slide the operating handle forward. Regrasp the magazine and hold it in the palm of your left hand (fig. 27).

b. At the commands **INSERT, MAGAZINE** or **PORT, ARMS**, pull the trigger on the preparatory command. On the command of execution, replace the magazine and resume the position of sling arms.

### **Section III. MANUAL OF ARMS FOR THE PISTOL**

#### **50. General**

a. Pistol movements are not executed in cadence.

b. When armed with the pistol, remain at attention during the manual of arms for the rifle.

c. Execute all movements and positions, except inspection arms, as without arms.

#### **51. Inspection Arms**

When armed with the pistol, for instructional purposes only, execute the following movements separately on the indicated commands, or in sequence when **INSPECTION, ARMS** is given (4, fig. 28).

a. *Raise Pistol.* At the command **RAISE, PISTOL**, unbutton the flap of the holster with your



*Figure 27. Inspection arms with the automatic rifle.*

right hand and grasp the pistol grip with the back of your hand outward. Draw the pistol from the holster. Bring your elbow to your side and hold your upper arm vertical and forearm at an angle from the vertical so that your hand is as high as, and approximately 6 inches in front of, your right shoulder. Hold the pistol grip with your thumb and last three fingers and extend your forefinger outside and along the trigger guard. Point the muzzle outward and up at approximately  $30^\circ$  from the vertical (1, fig. 28). If you are wearing a shoulder holster, at the command RAISE, PISTOL, unbutton the flap or snap fastener, draw the pistol from the shoulder holster, and assume the position of raise pistol.

*b. Withdraw Magazine.* At the command WITHDRAW, MAGAZINE, without lowering your right hand, turn the barrel slightly to the right, press the magazine catch with your right thumb, and remove the magazine with your left hand (2, fig. 28). Place the magazine between your belt and outer garment, on your left side, with the open end down, front to the right.

*c. Open Chamber.* At the command, OPEN, CHAMBER, without lowering your right hand, grasp the slide with your left thumb and first two fingers so that your thumb is on the left side of the slide and pointing downward. Keeping the muzzle elevated, shift the grip of your right hand so that your right thumb engages the slide stop; push the slide fully to the rear, and engage the stop in its notch with your right thumb (3, fig. 28). Resume the position of raise pistol, with the slide to the

rear. Take the magazine out of your belt and hold it in your open hand at the height of your belt with the open end of the magazine to the front and the front of the magazine to the left. If the inspecting officer takes your pistol for inspection, lower your right arm and hand smartly to your side as in the position of attention. Raise your right arm and hand to the raise pistol position when the inspector is ready to return the pistol.

*d. Close Chamber.* After your pistol has been inspected, or at the preparatory command of CLOSE, CHAMBER or PORT, ARMS, press the slide stop down with your right thumb and let the slide go forward. Pull the trigger and remain at raise pistol.

*e. Insert Magazine.* At the preparatory command of INSERT, MAGAZINE, without lowering your right hand, turn the barrel slightly to the right. Grasp the magazine with the first two fingers and thumb of your left hand and insert it in the pistol (2, fig. 28). At the command of execution, press the magazine fully home and resume raise pistol (1, fig. 28).

## **52. Return Pistol**

*a.* Execute this movement on the command, RETURN, PISTOL or on the command ORDER (RIGHT SHOULDER), ARMS after INSPECTION, ARMS and PORT, ARMS have been given.

*b.* On the command of execution, lower your pistol to the holster, muzzle down, with the back of your hand to the right. Then raise the flap of the holster with your right thumb, insert the muzzle of



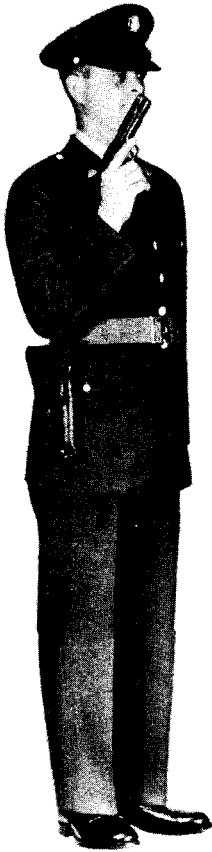

①



②

*Figure 28. Inspection arms with pistol.*



3



4

*Figure 28—Continued.*

the pistol into the holster and thrust it home. Button the flap of the holster with your right hand. When wearing a shoulder holster, at the command RETURN, PISTOL, return the pistol directly from the position of raise pistol to the holster and button the flap or snap fastener.

#### **Section IV. MANUAL OF ARMS FOR THE CARBINE**

##### **53. General**

*a.* Except when otherwise prescribed, carry the carbine slung over your right shoulder in a position similar to sling arms for the rifle (fig. 29). When armed with the carbine, remain at attention during the manual of arms.

*b.* During marches and field exercises, when left shoulder arms is commanded to ease fatigue, change the carbine to your left shoulder without cadence.

*c.* When at ease or rest is commanded, keep the carbine slung unless otherwise ordered.

*d.* Execute parade rest with the carbine at sling arms, as described for the rifle at sling arms.

*e.* When armed with the carbine, give the hand salute as prescribed in paragraph 46*d*.

##### **54. Inspection Arms**

*a.* INSPECTION, ARMS is commanded when at sling arms. At the command of execution, grasp the sling with your left hand above your right hand (1, fig. 30), and lift the carbine from your shoulder. At the same time, withdraw your right arm from between the carbine and the sling. Grasp the small of the stock with your right hand and bring the weapon across your body as in port arms with the rifle. Press the magazine lock to the left with the

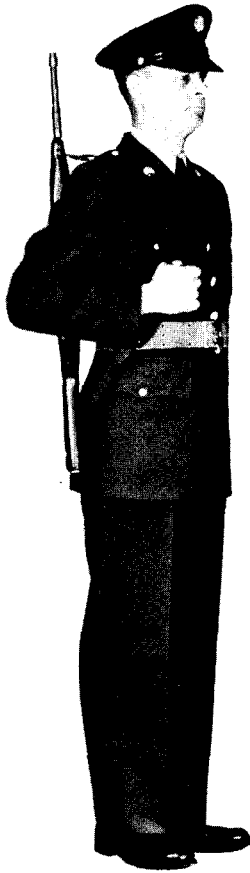

*Figure 29. Sling arms with the carbine.*



*Figure 30. Inspection arms.*



3



4

*Figure 30—Continued.*

forefinger of your right hand and, at the same time, withdraw the magazine from the receiver with your left hand. Insert it behind your belt in front of your left hip with the open end down and the front of the magazine to the right (2, fig. 30). Assume the position of port arms, which is similar to that for the rifle. With the forefinger of your right hand, pull the operating slide all the way back and press down on the operating slide stop with your right thumb, locking the operating slide in its rear position. At the same time, lower your head and eyes to glance into the chamber (3, fig. 30). Having found the chamber empty or having emptied it, raise your head and eyes to the front and regrasp the small of the stock in the position of port arms.

b. Inspection arms with the carbine is not a precision movement and is not executed as part of the manual of arms with the rifle, except when your unit is formed and dismissed, or for an inspecting officer.

c. At inspection arms, the only command is PORT, ARMS. At the preparatory command PORT, pull the operating slide to the rear with your right forefinger and release it without moving the carbine. Pull the trigger with your forefinger and regrasp the small of the stock with your right hand. At the command ARMS, replace the magazine with your left hand without moving the carbine, and resume port arms (4, fig. 30).

## **55. To Resume Sling Arms**

a. Execute SLING, ARMS on the commands ORDER (RIGHT SHOULDER), ARMS after INSPECTION, ARMS, and PORT, ARMS have been given.

*b.* At the command of execution, grasp the sling with your left hand, thrust your right arm through the sling, and assume the position of sling arms. This movement is not executed in cadence.

## Section V. MANUAL OF THE GUIDON

### 56. General

*a.* The guidon is a company (troop or battery) identification flag. It is carried at ceremonies and when otherwise prescribed by the commander.

*b.* The guidon bearer is specially selected by the company commander and receives special instruction in his duties. When armed with a rifle or carbine, the bearer slings the weapon behind his back, with the sling diagonally across his chest and the muzzle up and to the left, unless otherwise ordered.

*c.* To face with the guidon, raise the ferrule 3 inches off the ground by bending your right arm slightly. Execute this movement in a manner similar to facing with a rifle at order arms, but keep the staff in a vertical position throughout the movement.

*d.* Execute **PRESENT, ARMS**; **PARADE, REST**; **AT EASE**; **STAND AT, EASE**; and **REST** with the unit.

*e.* When marching at route step or at ease, you may hold the guidon in either hand at the carry position.

*f.* Execute **PARADE, REST** (par. 38) by inclining the staff of the guidon forward in the same manner as with the rifle, keeping the ferrule in the same position as in order guidon (fig. 31).





*Figure 31. Parade rest with the guidon.*

*g.* Execute **AT EASE** similarly to parade rest, except that you may slightly relax your right arm.

*h.* When given **REST**, hold the guidon in either hand.

*i.* When not in formation, render the salute similarly to the rifle salute as described in paragraph 45 (1 and 2, fig. 32).

## **57. Order Guidon**

When the troops are armed, execute order guidon on the command **ORDER, ARMS** from the company commander. With unarmed troops, execute order guidon automatically on halting. At order guidon, keep the ferrule on the ground and touching the outside of your right footgear, opposite the ball of your right foot. Hold the staff in your right hand in the **V** formed by your fingers extended and joined, and your thumb. Keep your right hand and arm behind the staff with your arm bent naturally. Rest the staff against the hollow of your shoulder (fig. 33). The remainder of the position of order guidon is the same as the position of attention.

## **58. Raise Guidon**

On the preparatory portion of all commands that begin, change, and discontinue marching movements, and on the preparatory commands for **COMPANY OR GROUP, ATTENTION; PRESENT, ARMS; and EYES, RIGHT**, raise the guidon to the raise guidon position by grasping the staff with your left hand, palm to the rear, at a point opposite your right elbow. Raise the staff with your left hand to a position approximately 6 inches off the ground. Keep your right



*Figure 32. Salutes with the guidon.*



*Figure 33. Order guidon.*

hand in its original position and allow the staff to slide through it. Regrasp the staff in its new position with your right hand and, at the same time, raise the staff with both hands until your right hand is as high as and in front of your right shoulder. Retain your grasp with both hands and keep your right elbow into your side. Keep the staff vertical (fig. 34). Hold the guidon in this position until the command of execution is given.

### **59. Carry Guidon**

*a.* To return to carry guidon from raise guidon, lower the staff smartly, keeping it vertical, until your right arm is fully extended. Return your left hand to your left side. The ferrule is now 6 inches off the ground and the staff is resting in the hollow of your right shoulder. The right hand grasps the staff in the most convenient manner (fig. 35). Return to carry guidon at all commands of execution while in the march.

*b.* To return to order guidon, follow the procedure as in *a* above on the command of execution, but let the staff slide through your right hand until the ferrule touches the ground.

*c.* At double time, hold the guidon diagonally across your body. Grasp the staff with your right hand at the position used at the carry, with your right forearm horizontal and your elbow near your body. Grasp the staff in your left hand opposite the junction of your neck and left shoulder.

### **60. Present Guidon**

*a.* At ARMS of PRESENT, ARMS or RIGHT of EYES, RIGHT, lower the guidon smartly to the front



*Figure 34. Raise guidon.*

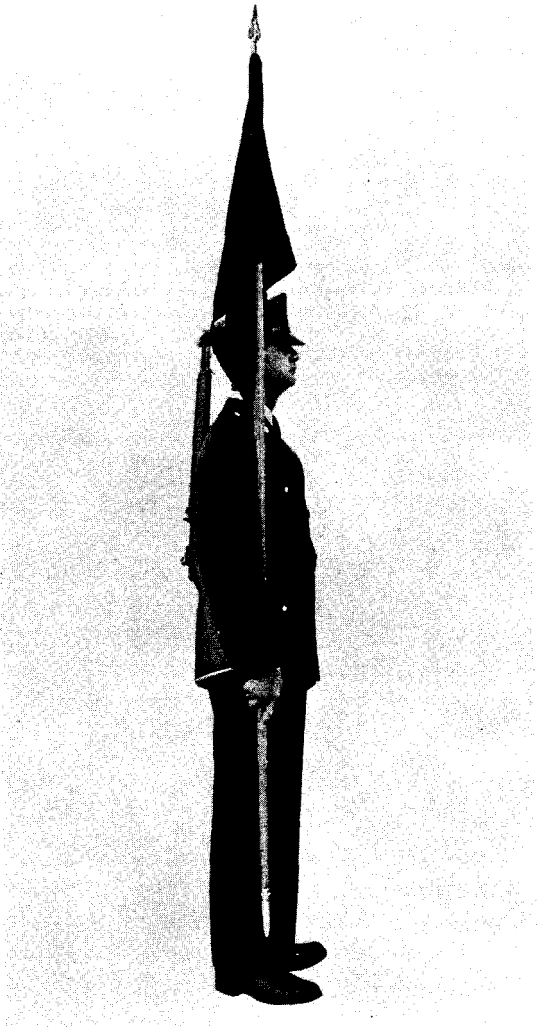

*Figure 35. Carry guidon.*

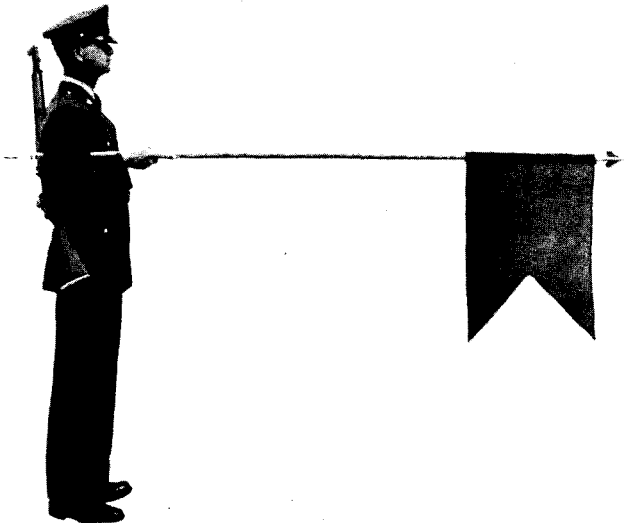

*Figure 36. Present guidon.*

from the raise guidon position by lowering your left arm to a diagonal position in front of your body. Rest the staff in your armpit and hold it horizontal. Keep your right forearm along the right side of the staff, upper arm vertical and into your body. The point of the ferrule slightly protrudes behind your back. At the same time, move your left hand smartly away to your side (fig. 36).

b. When passing in review, execute **EYES, RIGHT** as you present the guidon, and **READY, FRONT**, as you bring the guidon back to carry. On the command **READY** of **READY, FRONT**, regrasp the staff with your left hand and execute raise guidon; on **FRONT**, return to carry guidon.



## CHAPTER 5

### THE SQUAD

---

#### Section I. GENERAL

##### 61. General

*a.* Training in individual movements and the manual of arms is followed by dismounted drill. This training is progressive and includes three phases: squad, platoon, and company drill. In the first phase, you begin to play your part on a team—the squad. In squad drill, you learn to do all the individual movements together with other men.

*b.* When the squad leader is absent, the second in command takes over his duties and assumes his normal position.

*c.* Individual members of a squad are numbered from right to left when in line, and from front to rear when in column.

##### 62. Definitions

To help understand the meaning of drill terms in this chapter, the following definitions are included:

*a. Formation* is the arrangement of the elements of a command in any prescribed manner.

*b. Line* is a formation in which the elements of a command (other than a platoon) are side by side, or abreast of each other. Two or more elements constitute a line.

*c. Rank* is a line which is only one element in depth.

*d. Interval* (fig. 37) is the lateral space between elements. *Normal interval* between men is measured from right to left by the man on the right holding his left arm and hand shoulder high, fully extended, with the tip of his middle finger touching the right shoulder of the man on his left. *Close interval* between men is measured from right to left by the man on the right placing the heel of his left hand on his left hip, fingers joined and extended downward, and his elbow in line with his body and touching the arm of the man on his left. *Double arms interval* between men is measured from right to left by the man on the right holding his left arm and hand shoulder high, fully extended. The man to his left obtains double arms interval by holding his right arm and hand shoulder high, fully extended, so that their finger tips touch.

*e. Column* is a formation in which the elements of a command (other than a platoon) are one behind the other, except when the squad is in a column of twos or part of the next larger unit.

*f. File* is a column which has a front of only one element.

*g. Distance* (fig. 37) is the space between elements in column. *Normal distance* for men is the space from the back of a man to the chest of the man immediately to his rear when they have formed in line, obtained normal interval, and faced to the right or left.

*h. Head* is the leading element of a column.

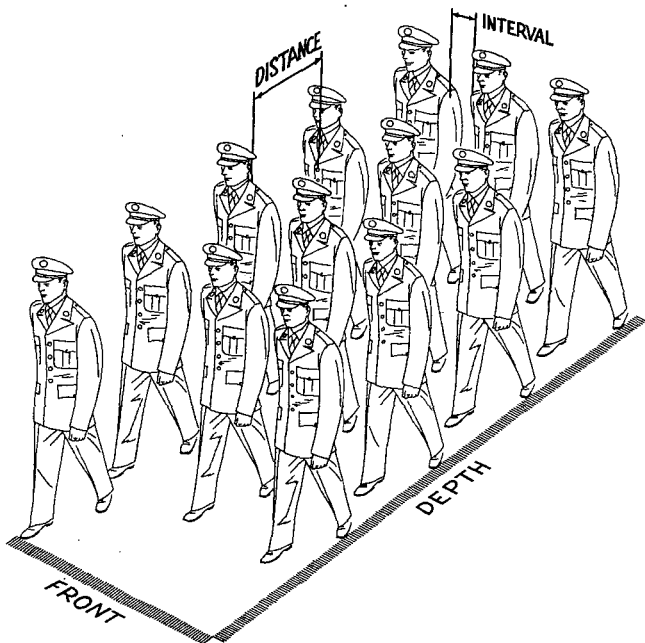

Figure 37. Distance, interval, front, and depth.

*i. Cover* is alining yourself directly behind the man to your immediate front while maintaining proper distance.

*j. Flank* is the right or left side of any formation as sensed from an element of that formation.

*k. Front* is the space from side to side of a formation, including the right and left elements (fig. 37).

*l. Measurements* of an individual normally are 12 inches in depth and 22 inches in width.

*m. Depth* is the space from front to rear of a formation, including the front and rear elements (fig. 37).

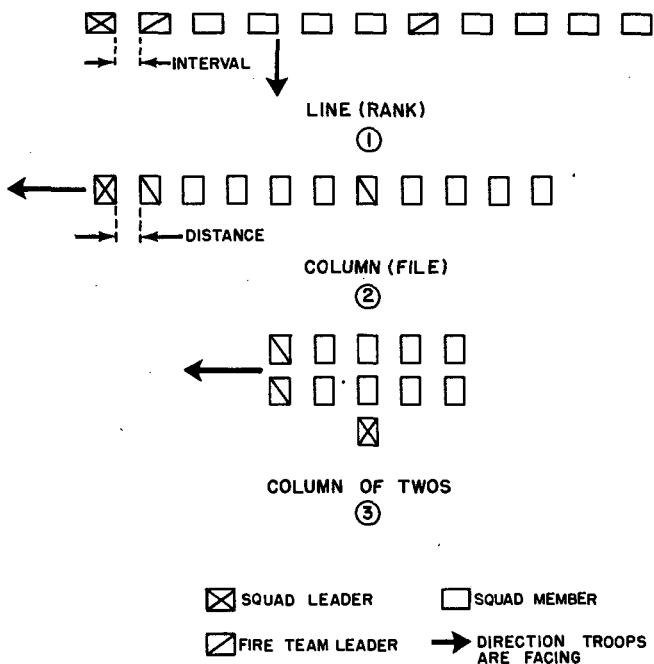

Figure 38. Squad formations.

*n.* *Base* is the element on which a movement is planned or regulated.

### 63. Formations

The squad has three prescribed formations: a line (1, fig. 38), a column (file) (2, fig. 38), and a column of twos (3, fig. 38).

*a.* The squad forms in line with squad leader on the right.

*b.* The squad normally marches in column (2 and 3, fig. 38), but it may march in line for short dis-

tances only. When it is part of a larger unit, the squad normally marches in column (file) as shown in 2, figure 38.

*c.* When the squad drills as a separate unit, the squad leader takes a post three steps in front of and centered on the squad when it is in line; and three steps to the left and centered on the squad when it is in column (file) or in column of twos.

## **Section II. SQUAD DRILL**

### **64. To Form the Squad**

*a.* To form at normal interval (fig. 39) the squad leader assumes the position of attention and commands **FALL IN**.

*b.* When the squad forms as a separate unit, the next senior member assumes the number one position which is the right flank man. At the command **FALL IN**, the number one man positions himself so that the squad, when formed, will be three steps in front of and centered on the squad leader. The number one man immediately raises his left arm laterally at shoulder level, fingers extended and joined, palm down, with head and eyes to the front. The number two man takes his position immediately to the left of number one and on line, his right shoulder touching number one's fingertips; he turns his head and eyes to the right for alinement and raises his left arm. As soon as proper interval has been obtained, the number one man drops his left arm quietly to the side. The number two man turns his head and eyes to the front when he is alined. Other members of the squad form in the same manner as the number

two man. The left flank man does not raise his left arm.

*c.* When the squad is part of a larger unit, the squad leader is the right flank man.

*d.* To form at close interval (fig. 40) the command is AT CLOSE INTERVAL, FALL IN. The formation is completed like normal interval, except that close interval is obtained as described in paragraph 62*d*.

*e.* When armed, the men fall in at the order. Weapons are inspected after falling in by the commands INSPECTION, ARMS; PORT, ARMS; and ORDER, ARMS.

### **65. To Dismiss the Squad**

*a.* The squad is dismissed only from a line formation with the men at attention.

*b.* With armed troops, the commands are INSPECTION, ARMS; PORT, ARMS; DISMISSED.

*c.* With unarmed troops, the command is DISMISSED.

### **66. To Change Interval While in Line**

*a.* To obtain close interval from normal interval, the command is CLOSE, MARCH. On the command of execution, the right flank man stands fast. All men to his left, face to the right in marching from the halt, march forward until they have obtained the approximate close interval, halt, and face to the left. The squad then forms at close interval without command, as explained in paragraph 64*d*.

*b.* To obtain normal interval from close interval, the command is EXTEND, MARCH. At the command MARCH, all men except the right flank man face to

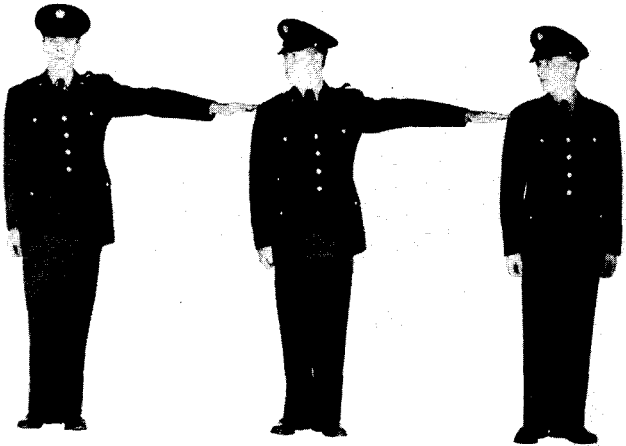

*Figure 39. Normal interval.*

the left in marching from the halt, march forward until approximately normal interval is obtained, halt, and face to the right. The squad then forms at normal interval without command, as explained in paragraph 64*b*.

*c.* To obtain double-arm interval from normal interval, the command is TAKE INTERVAL, MARCH. This movement is executed as when extending, except that the double-arm interval is obtained by each man raising both arms and touching the fingertips of the man on his right. Drop your right arm when the interval has been obtained; your left arm when the man on the left drops his right arm. Turn your head and eyes to the front as you drop your right arm. In executing this movement, the right flank man does not raise his right arm and the left flank

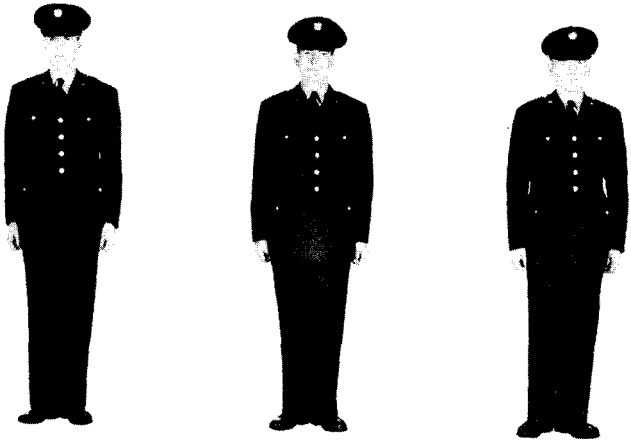

Figure 39—Continued.

man does not raise his left arm. With armed troops, sling arms is given before commanding this movement.

*d.* To obtain normal interval from double-arm interval, the command is **ASSEMBLE, MARCH**. Execute this movement like **CLOSE, MARCH**, but form at normal interval.

### **67. To Aline the Squad**

*a.* To aline the squad at normal interval, the commands are **DRESS RIGHT, DRESS; READY, FRONT**. These commands are given only when the men are at order arms or sling arms. At the command **DRESS**, each man except the *right* flank man turns his head and eyes to the *right* and alines himself on the right flank man. Each man except the *left* flank man extends his *left* arm, and each man

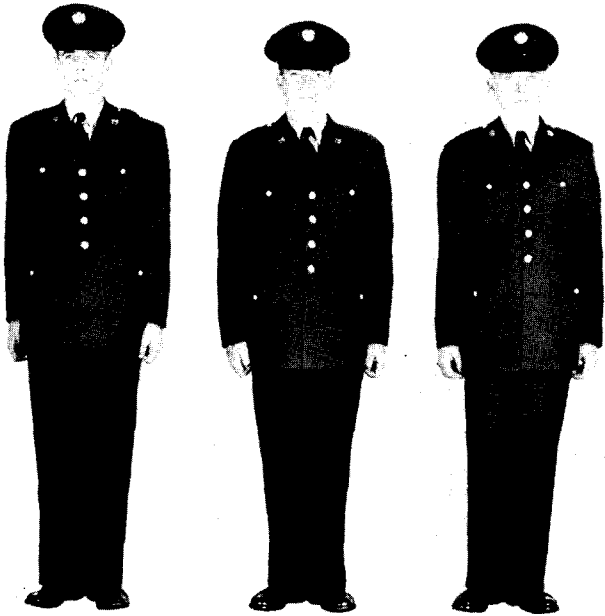



*Figure 40. Close interval.*

positions himself by short right or left steps until his *right* shoulder touches the fingertips of the man on his *right*.

*b.* The squad leader marches by the most direct route to a position on line with the squad, one step from the right flank man, halts on line, and faces down the line. From this position, he verifies the alinement of the squad, ordering men to move forward or backward as necessary, calling them by name or number; e. g., Private Jones, forward 2 inches; number 8 man, back 4 inches. The squad leader remains at attention, taking short steps to the right or



*Figure 40—Continued.*

left as necessary to see down the squad. He does not use his arms or twist his body. Having checked the alinement, he faces to the right in marching, halts 3 steps in advance of the squad, executes left face, and commands **READY, FRONT**. At the command **FRONT**, the men drop their arms quietly to their sides and turn their heads and eyes smartly to the front. The squad leader then marches to his front until he is centered on the squad where he halts and faces the squad.

c. To aline the squad at close interval, the commands are **AT CLOSE INTERVAL, DRESS RIGHT, DRESS**;

**READY, FRONT.** The movement is executed as described in *a* and *b* above, except that close interval is obtained by placing the left hand on the hip at the belt line, fingers extended and joined, pointing downward, elbow on line with the body.

*d.* To dress the squad in column, the command is **COVER.** At this command, each man covers the man in front of him and obtains the approximate distance.

### **68. To March in Column From Squad in Line at the Halt**

*a.* The commands are **RIGHT (LEFT), FACE; FORWARD, MARCH.** These movements are executed as explained in the school of the soldier without arms.

*b.* When at close interval, the squad is extended to normal interval before being faced and marched off.

### **69. To Change the Direction of a Column**

*a.* The command is **COLUMN RIGHT (COLUMN LEFT, COLUMN HALF RIGHT, COLUMN HALF LEFT), MARCH.**

*b.* From a halt, at the command **COLUMN RIGHT** or **COLUMN HALF RIGHT, MARCH,** the leading man takes a 30-inch step to the front with his left foot which will allow following men to pivot on approximately the same ground, turns to the right on the ball of his left foot, and steps off in the indicated direction, taking a full step with his right foot. All other men march forward and turn in the same manner on approximately the same ground as the leading man, following in column until another command is given. On the command **COLUMN LEFT (HALF LEFT), MARCH** from a halt, the leading man

faces to the left in marching, pivoting on the ball of his right foot and, at the same time, steps off in the new direction with a full step with his left foot. All other men march forward and pivot on approximately the same ground.

*c.* When marching, the preparatory command and command of execution for each movement are given so they end on the foot in the direction of the turn; **COLUMN RIGHT, MARCH** and **COLUMN HALF RIGHT, MARCH** are given as the right foot strikes the ground and **COLUMN LEFT, MARCH** and **COLUMN HALF LEFT, MARCH** as the left foot strikes the ground. The interval between the preparatory command and the command of execution is one step. At the command **MARCH**, the leading man executes a face in marching from the march. All other men execute the same movement in succession on approximately the same point.

*d.* While marching, the command **INCLINE TO THE RIGHT (LEFT)** is given for slight changes of direction to avoid obstacles, after which the original direction is resumed. The leading man changes direction as commanded. All other men turn in the same way as they come to the point on which the leading man turned. This is not a precision movement.

## **70. March to the Flank**

When it is desired to move a unit to the flank for a short distance while marching at quick time, the commands are **RIGHT (LEFT) FLANK, MARCH**. The preparatory command and the command of execution end when the foot in the indicated direction of march strikes the ground. The interval between the

preparatory command and the command of execution is one step. At the command MARCH, each man takes one more step, turns in the indicated direction of march on the ball of his leading foot, and steps off in the new direction with his trailing foot. This movement is used to march a unit to the right or left for a short distance and is not executed from the halt.

## **71. To Count Off in Line or Column**

*a.* For drill purposes, counting off is executed only from right to left in line and from front to rear in column. The command is COUNT, OFF.

*b.* When in line, at the command of execution, all men except the man on the right flank turn their heads and eyes to the right and the right flank man counts off ONE. After the man on the right counts off his number, the man to his left counts off the next higher number, at the same time turning his head and eyes to the front. The numbers are counted in the cadence of quick time from man to man. All movements are made in a precise manner.

*c.* When in column, at the command of execution, each man in succession (starting with the leading man) turns his head to the right and counts off his number sharply over his right shoulder. He then turns his head back to the front. The last man in column keeps his head and eyes to the front.

## **72. To Stack Arms**

*a.* The members of the squad stack arms from their positions in line at normal interval on the command STACK, ARMS. After the squad counts off, the commander designates the stackmen by numbers be-

fore giving the command to stack arms. Only those riflemen with other riflemen on each side of them can be designated as stackmen.

*b.* At the command ARMS, the man on the left of the stackman grasps his rifle at the lower portion of the front hand guard and passes it in a vertical position to the right front (approximately 30°) to the stackman, who grasps it with his left hand at the upper portion of the front hand guard. The stackman places the butt of the rifle between his feet, with the barrel to the front, muzzle outward, and with the thumb and forefinger of his left hand raises the stacking swivel. He then swings the butt of his own rifle 2 feet in front and 6 inches to the right of his right toe (2, fig. 41). At the same time, he shifts his right hand to the stacking swivel of his rifle and engages it with that of the left rifle. The stackman's rifle is on the right.

*c.* The man on the right of the stackman steps to the left front with his left foot, keeping his right foot in place. At the same time he bends to the left front, regrasping his weapon with his left hand at the front hand guard and his right hand at the small of the stock. He then slides his left hand up to manipulate the stacking swivel, engaging it with the free hook of the swivel on the stackman's rifle (fig. 41). He rotates the rifle outward so that the barrel rests in the angle formed by the other two rifles and above the bayonet stud on the left rifle (5, fig. 41). He pulls the butt toward him until the stack is tight and the butt is in line with the butt of the rifle between the stackman's feet. He



①

*Figure 41. Stack arms.*

then lowers the butt to the ground and resumes the position of attention (4, fig. 41).

*d.* Other rifles, carbines, or automatic rifles are passed to the nearest stack on the right. When passing extra rifles to the stack, grasp the front hand guard with your right hand and, holding the rifle vertical, fully extend your arm to your right front as shown in 1, figure 41. When the man on your right has grasped the rifle at the balance with his left hand, release your right hand and resume the position of attention. When you have received a rifle from the man on your left, keep it vertical and move it in front of you, with your left hand at the balance; grasp the front hand guard with your

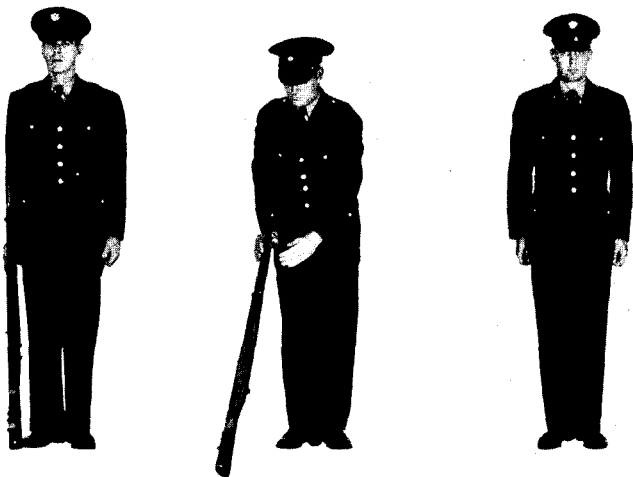

②

*Figure 41—Continued.*

right hand and, if you are not the stackman, pass it to your right as described above. If you are the stackman, place the rifle on the stack, trigger guard outward, at a sufficient angle from the vertical to keep it in place.

### **73. To Take Arms**

*a.* The squad, in position in line behind the stacks, takes arms at the command **TAKE, ARMS.**

*b.* At the command **ARMS**, the stackman passes each extra rifle toward its bearer. The rifles are held in the manner described for passing them to the stack (left hands at the balance; right hands at the front hand guard). When the weapons are re-





③

*Figure 41—Continued.*

ceived, their bearers resume the position of order arms.

*c.* When the extra rifles have been passed, the stackman grasps his rifle and the rifle of the man on his left. The man on the right of the stackman steps to the left front as in stacking, secures his rifle, and resumes the position of order arms.

*d.* The stackman then disengages the two remaining rifles, grasps the left rifle at the lower part of the front hand guard and passes it to his left front. The man on his left grasps it at the front hand guard with his right hand and lowers the rifle to the ground, resuming order arms. The stackman resumes order arms after the man on his left has received his rifle.

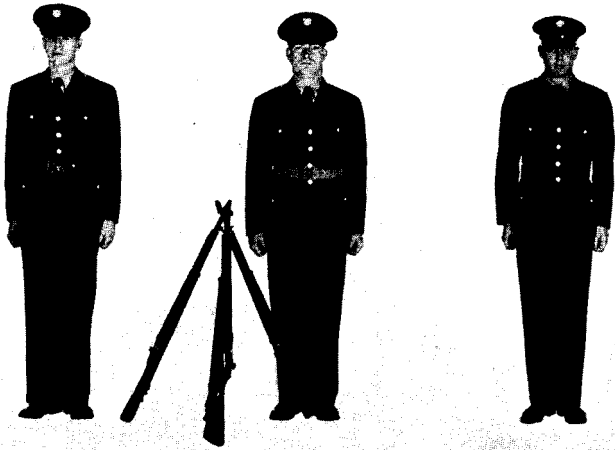

④

Figure 41—Continued.

*e.* Each man comes to order arms by guiding and steadying the piece with his left hand as in the next to the last count of order arms (fig. 18). If armed with the automatic rifle or the carbine, assume the position of sling arms.

#### **74. To Form a Column of Twos From a File and Re-Form**

*a.* When at a halt and in file, the command is **COLUMN OF TWOS TO THE LEFT (RIGHT), MARCH.**

*b.* On the preparatory command, the number one fire team leader commands **STAND FAST.** The number two fire team leader commands **COLUMN HALF LEFT (HALF RIGHT).** On the command **MARCH,** the number two team leader executes a column half right (left), then inclines right (left),

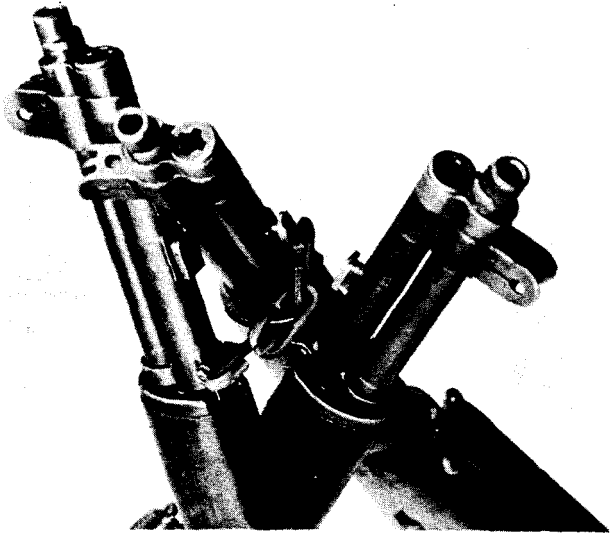

⑤

*Figure 41—Continued.*

halting abreast of the number one team leader at normal interval.

*c.* When in a column of twos at the halt, the command to re-form is **FILE FROM THE RIGHT (LEFT), MARCH.**

*d.* On the preparatory command, the number one fire team leader commands **FORWARD.** The number two team leader commands **STAND FAST.** Upon the command of execution **MARCH,** the number one team marches forward. The number two team leader commands **COLUMN HALF RIGHT (LEFT), MARCH,** and then inclines right (left) to follow the number one team at normal distance.

## 75. To March to the Oblique

*a.* To march to the oblique when marching in a column formation at quick time, the command is **RIGHT (LEFT) OBLIQUE, MARCH**. The word "oblique" is pronounced to rhyme with strike.

*b.* When teaching marching to the oblique, the squad leader first alines the unit and has each man execute a half right (left) face. The squad leader points out each man's position and explains that each man is to maintain this position while marching by keeping his shoulders parallel to the man in front (fig. 42).

*c.* At the command of execution **MARCH**, given on the foot in the direction of turn, each man takes one more step in the forward direction, faces to the half right (left) in marching, and steps off with the trailing foot and continues the march in a direction of  $45^\circ$  to the right (left) of the original direction of march.

*d.* The command **FORWARD, MARCH** is given to resume the original direction of march from marching in the oblique. At the command **MARCH**, take one more step, pivot on the ball of the leading foot in marching, and continue to march to the original front.



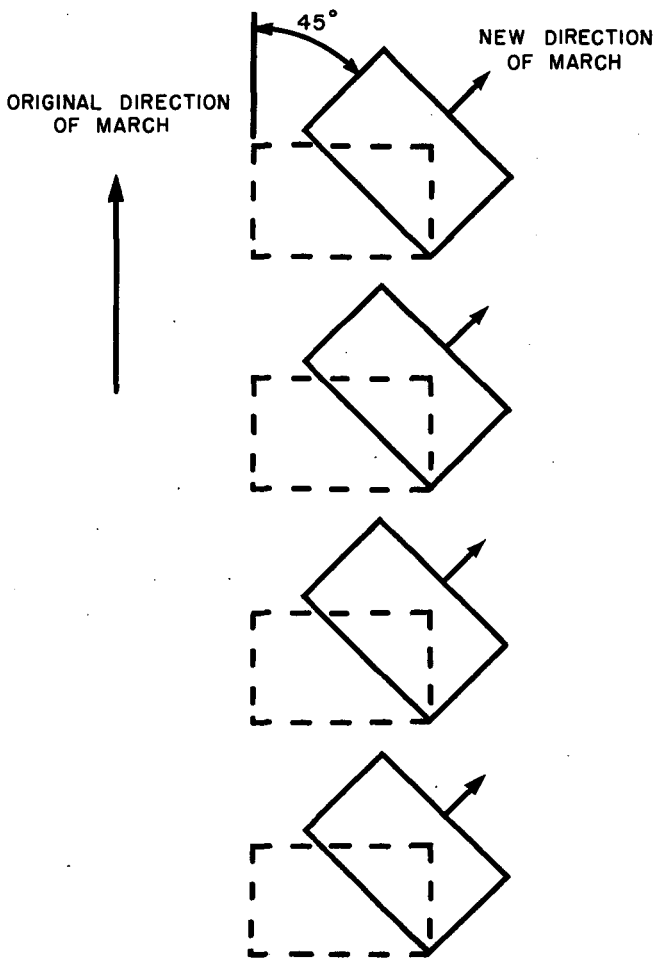

*Figure 42. Right oblique.*

## CHAPTER 6

### THE PLATOON

---

#### Section I. GENERAL

#### 76. General

*a.* Upon completion of the first phase of dismounted drill, your squad is merged with other squads into a platoon where you learn other movements.

*b.* The platoon consists of a platoon headquarters and two or more sections or squads. The platoon headquarters consists of a platoon leader and one or more assistants.

*c.* The elements (squads) of a platoon are numbered from front to rear when in line, and from left to right when the platoon is in column.

#### 77. Definitions

To help understand the meaning of certain drill terms in this chapter, the following definitions are given:

*a. Platoon base* for a platoon in column is the squad behind the platoon guide.

*b. Guide* is the man responsible for maintaining the prescribed direction and rate of march for the platoon. The platoon sergeant is the guide. When the platoon is in line at the halt, the guide's position is always on the right flank of the platoon and at normal interval to the right of the first squad leader.

The guide does not change his position when the platoon is marched for short distances in a line formation. When the platoon is in a column formation, the guide's position is in front of the right squad leader, at normal distance.

*c. Platoon line* is a formation in which the elements (squads) are in line and one behind the other (1, fig. 43).

*d. Platoon column* is a formation in which the elements (squads) of a platoon are in column and abreast of each other (2, fig. 43).

*e. Post* is the correct place for an officer or non-commissioned officer to stand in a prescribed formation.

## **78. Rules for the Guide**

*a.* The guide of a unit is always on the right.

*b.* When a platoon in line is given the command **RIGHT, FACE**, the guide executes right face with the platoon. Then he immediately faces to the right in marching, marches forward, halting in front of the right squad leader, and executes left face.

*c.* When a platoon in column is given the command **FILE FROM THE LEFT, MARCH**, on the preparatory command, the guide takes his position in front of the left file so that he is at the head of the column.

*d.* When a platoon in column is given the command **COLUMN OF TWOS FROM THE LEFT, MARCH**, on the preparatory command, the guide takes his position in front of the second file from the left so that he is at the head of the right file of the column that is to move out.

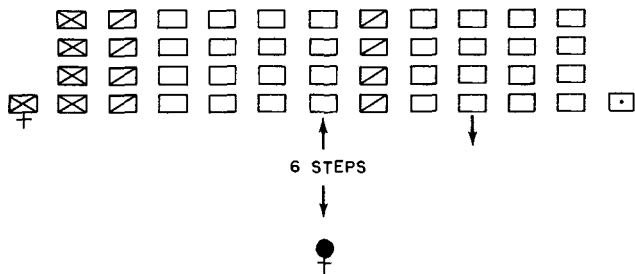

RIFLE PLATOON IN LINE

1

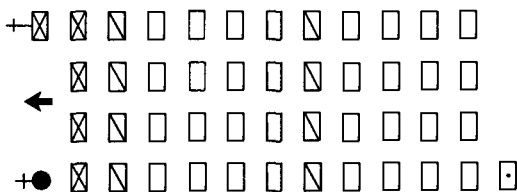

RIFLE PLATOON IN COLUMN

2

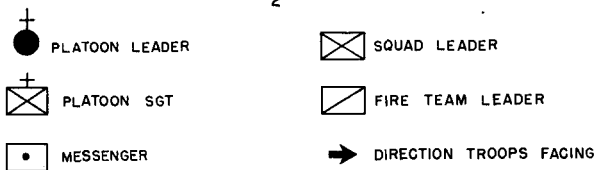

*Figure 43. Platoon formations.*



*e.* When re-forming in a column of fours from a file or column of twos, the guide posts himself in his normal position when the movement is completed.

*f.* The guide is responsible for setting the direction of march by inclining to the right or left when necessary, and for setting the proper cadence. The leading man of each file is responsible for the interval.

*g.* When a platoon is marching in column and the command to march by a flank or to the rear is given, the guide executes the movement with the platoon but does not change his position within the platoon.

### **79. Squad Drill Applicable to Platoon Drill**

The following movements are executed as in squad drill, with the exceptions and additions noted.

*a.* The platoon is dismissed by the platoon sergeant in the same manner as the squad.

*b.* The platoon changes interval while in line and counts off in the same manner as the squad with the squad leaders as bases for these movements. When there are two or more ranks, the men in rear of the first rank cover the corresponding man to their front in executing these movements. When there is only one rank, the first (or right) squad leader is base. The guide moves to the right when interval is taken to the left, and does not count off.

*c.* The platoon marches from a line in the same manner as a squad, the guide taking his post as described in rules for the guide (par. 78).

*d.* The platoon stacks arms as described in paragraph 72 after first opening ranks. The guide passes his rifle toward the nearest stack to his left, holding the rifle at the balance with his left hand as in taking arms (par. 72*d*).

*e.* The platoon executes flank movements in a manner similar to that described for the squad, except when the platoon is at close interval between files. In this case, it must first be extended to normal interval.

*f.* To dress the platoon while in column, the command is COVER. The base squad leader obtains normal distance from the guide. The remaining squad leaders obtain the proper interval from the base squad leader and aline on him. All other men in the base squad execute the movement as in squad drill. At the same time the remaining men of the platoon aline on the base squad and cover their squad leaders.

## **80. Formations**

The platoon has two prescribed formations: a column and a line.

*a.* The platoon forms in line with the squad leaders on the right of their squads (1, fig. 43). The platoon sergeant forms the platoon from his post three steps in front of and centered on the platoon. In line, with the platoon leader in command, the platoon sergeant's post is to the right of the right flank man of the front rank at normal interval. The platoon leader's post is six steps to the front of and centered on the platoon. When marching in line, the guide and squad leaders are on the right. The platoon marches in line for short distances only.

*b.* When the platoon sergeant is performing the duties of the platoon leader, the senior squad leader assumes the duties and post of the platoon sergeant.

*c.* In the column formation, the platoon leader is in front of the left file, the platoon sergeant in front

of the right file, all at normal distances when part of a larger unit. When the platoon is drilling as a separate unit, the platoon leader is three steps to the left and centered on the left flank of the platoon as described for the squad leader (3, fig. 38). The platoon normally marches in column with the guide and squad leaders at the head.

## Section II. PLATOON DRILL

### 81. To Form the Platoon

*a.* The platoon is usually formed at normal interval by the platoon sergeant with the command, **FALL IN.**

*b.* At this command, the squad leader of the first squad posts himself so that the first squad, when dressed on him, will be centered on and three 30-inch steps from the platoon sergeant. Other squad leaders cover the first squad leader at normal distance. The members of the squads fall in on their squad leaders as prescribed in squad drill. Exact interval is taken only by the first squad. Men in the rear squads raise their left arms, take approximate interval only, and cover the corresponding man in the front rank. Messengers and attached personnel fall in at the left of the platoon to even the length of the ranks without disrupting the organization of the squads.

*c.* When the platoon is formed, the platoon sergeant commands **INSPECTION, ARMS; PORT, ARMS; ORDER, ARMS.** On his next command, **REPORT,** the squad leaders in succession from front to rear, salute and report in one of the following manners: "All present" or "Private . . . . . and Cor-

poral . . . . . absent." Each squad leader executes the rifle salute at order arms and holds the salute until the platoon sergeant returns it at the completion of the report. If armed, the platoon sergeant returns each squad leader's salute by executing the rifle salute from right shoulder arms. The platoon sergeant then faces about and reports to the platoon leader, "Sir, all present," "All present or accounted for" or "(so many) men absent." The platoon leader and platoon sergeant exchange salutes, the platoon leader executing the hand salute. The platoon sergeant then faces about, faces to the half left in marching, and takes his post to the right of the right flank man in the first squad, executes order arms, and faces about. He marches to his post in the most direct manner.

*d.* To form at close interval, the command is **AT CLOSE INTERVAL, FALL IN**. The formation is executed as described in *b* above, except that close interval is obtained as described in paragraph 64*d*.

## **82. To Aline the Platoon**

*a.* When in line, the platoon is alined similarly to the squad (par. 67). The platoon leader verifies the alinement.

*b.* To aline the platoon, the command is **DRESS RIGHT (AT CLOSE INTERVAL), DRESS**, given by the platoon leader. On the command of execution **DRESS**, the squad leader of the first squad momentarily glances to the right to aline himself on the guide, then turns his head and eyes back to the front. The guide raises his left arm during alinement. Other squad leaders obtain normal distance.

*c.* All men except the left flank men raise their left arms when alining. Only the first squad obtains the exact interval. All other squads get approximate interval; each man covers the man to his front and, at the same time, alines himself on his squad leader.

*d.* At the command DRESS, the platoon leader marches by the most direct route to the right flank of the platoon, halts on line and one step from the guide, and executes right face. He then alines the first squad as described in paragraph 67. After alining the first squad, the platoon leader faces in marching, takes two short steps to the next squad, halts, executes right face, and alines the squad in the same manner as the first squad. He alines all other squads in the same manner.

*e.* After alining the last squad, the platoon leader faces in marching from the halt and moves to a position three steps in advance of the platoon flank, halts, faces to the left, and commands, READY, FRONT. He then moves by the most direct route to his post six steps in front of and centered on the platoon.

### **83. To Open and Close Ranks**

*a.* When in line at normal interval, the platoon opens ranks for stacking arms or other purposes at the command OPEN RANKS, MARCH. At the command MARCH, the front rank takes two steps forward, the second rank takes one step, and the third rank stands fast. Each rank executes dress right on halting. If there are more than three ranks, the fourth rank takes two steps backward, the fifth rank takes four steps backward, and the sixth rank takes six steps backward. The platoon leader verifies the alinement as described in paragraph 82.

b. To close ranks, the command is **CLOSE RANKS, MARCH**. At the command **MARCH**, the front rank stands fast. The second, third, and succeeding ranks take one, two, three or more steps forward respectively, maintaining cover and alinement.

#### **84. To Change Interval While in Column**

a. When in column at normal interval, at a halt or in march at quick time, to obtain close interval between files the command is **CLOSE, MARCH**.

b. At the halt, on the command **MARCH**, the base squad stands fast. The other squads obtain close interval by taking 2, 4, and 6 right steps respectively, and cover their squad leaders.

c. When marching, the command **CLOSE, MARCH** is given on the right foot. At the command **MARCH**, the right squad takes up the half step. Other men face to the half right in marching and march until close interval is obtained. Then they face to the half left in marching, and take up the half step when abreast of the corresponding member of the base squad. At the command **FORWARD, MARCH**, all squads resume the 30-inch step.

d. To obtain normal interval between files, when the platoon is in column at close interval, at a halt or in march at quick time, the command is **EXTEND, MARCH**. This movement is executed like close march, but in the opposite direction.

#### **85. To Change the Direction of a Column**

a. To change the direction of a column, the command is **COLUMN RIGHT (COLUMN LEFT, COLUMN HALF RIGHT, OR COLUMN HALF LEFT), MARCH**, given at the halt or while marching in column. The base

element during the turn is the squad on the flank in the direction of the turn. The pivot man for this movement is the first man in the base squad, exclusive of the platoon leader or the platoon guide. When **COLUMN RIGHT (HALF RIGHT)**, **MARCH** is commanded from a halt, the guide faces to the right (half right) in marching at the command of execution.

*b.* The base squad executes this movement as in squad drill, except that each man takes up the half step after executing the face in marching until the corresponding men in the other squads come abreast.

*c.* All other squads execute two column half rights (lefts); the first half column movement is made at the line where the first rank executes the turn; the second, upon reaching a line running through the base squad's pivot, and parallel with the new front. Men in squads other than the base take up the half step as they come abreast of the corresponding men in the base squad. When all the men in a rank are abreast, they step off with the 30-inch step without command.

*d.* The command **INCLINE TO THE RIGHT** (or **LEFT**) is given for slight changes in direction. This is not a precise movement. After completing the turn, the base squad leader covers the guide and the platoon dresses and covers on the base squad. The base is normal and not changed by the direction of turn.

## **86. To Form a File and Re-Form From a Halt**

*a.* When the platoon is in a column of two or more files at a halt, it forms a single file at the command **FILE FROM THE RIGHT (LEFT)**, **MARCH**.

b. The squad leader of the designated lead file gives the supplementary command **FORWARD**, and the other squad leaders command **STAND FAST**. (When forming a file from the *left*, the guide positions himself in front of the left file on the preparatory command, **FILE FROM THE LEFT**.)

c. On the command of execution, the leading squad marches forward. The squad leader immediately to the left (right) of the base squad commands **COLUMN HALF RIGHT (LEFT), MARCH** and, after starting the movement, inclines to the left (right) without command, following the line of march of the preceding squad. The remaining squad leaders command **COLUMN HALF RIGHT (LEFT), MARCH**, and **COLUMN HALF LEFT (RIGHT), MARCH** so as to follow the preceding squads at normal distance. The squad leaders give their commands of execution to set their squads in march when the right foot of the marching squad strikes the ground. The squad leaders glance over their shoulders to see when the first half column movement should be given.

d. A column movement may be executed and a file formed from a column formation by the command **FILE FROM THE RIGHT (LEFT), COLUMN RIGHT (LEFT), MARCH**. The squad leader of the squad leading the movement gives **COLUMN RIGHT (LEFT)** instead of **FORWARD** after the preparatory command, and the other squad leaders give **STAND FAST**. The remaining squad leaders command **COLUMN RIGHT (COLUMN LEFT), MARCH** as the last man in the preceding squad reaches the pivot point.

e. When in a file at a halt, to re-form in the original column, the command is **COLUMN OF TWOS (FOURS) TO THE LEFT (RIGHT), MARCH**.



*f.* On the preparatory command, the squad leader of the base (leading) squad commands **STAND FAST**. All other squad leaders command, **COLUMN HALF LEFT (RIGHT)**.

*g.* At the command **MARCH**, the base (leading) squad stands fast. All other squads execute the column half left (right) simultaneously. The squad leader immediately in rear of the base squad then inclines to the right (left) without command. The other squad leaders command **COLUMN HALF RIGHT (LEFT)**, **MARCH** and **SQUAD HALT**, so as to bring their squads abreast of the base (leading) squad.

### **87. To Form a Column of Twos From a Column of Fours and Re-Form From a Halt**

*a.* When in a column of fours at a halt, to form a column of twos, the command is **COLUMN OF TWOS FROM THE RIGHT (LEFT)**, **MARCH**.

*b.* On the preparatory command, the squad leaders of the two squads which are to move out first command **FORWARD**. The other two squad leaders command **STAND FAST**. The guide positions himself in front of the right squad of the two squads which are to move out.

*c.* On the command of execution, the two right squads march forward. The other two squads move into the column of twos at normal interval at the commands **COLUMN HALF RIGHT (HALF LEFT)**, **MARCH**, **COLUMN HALF LEFT (HALF RIGHT)**, **MARCH**, given by the squad leader next to the two moving squads.

*d.* A column movement may be executed while forming the column of twos from a column of fours in the same manner as prescribed in paragraph 86.

*e.* When in a column of twos at a halt, to re-form in the original column of fours, the command is COLUMN OF FOURS TO THE LEFT (RIGHT), MARCH.

*f.* On the preparatory command, the two leading squad leaders command STAND FAST. The two rear squad leaders command COLUMN HALF LEFT (RIGHT). On the command MARCH, the two leading squads stand fast. The two rear squads execute COLUMN HALF LEFT (RIGHT), MARCH, COLUMN HALF RIGHT (LEFT), MARCH, halting at normal interval abreast of the base squads on command of the squad leader nearest the base squads.

### **88. To Form for Shelter Tents and Re-Form**

*a.* Shelter tents are pitched in line and in formation only for purposes of instruction and for formal field inspections or the display of equipment. Normally, in bivouac, full use is made of available cover and concealment, and straight lines are avoided.

*b.* The platoon is formed in one line for pitching shelter tents. Squad lines may be used when only a small space is available.

*c.* When the men are armed with rifles, the rifles are slung before forming for shelter tents.

*d.* When the platoon is in line, form it in one rank for pitching shelter tents by commanding FORM FOR SHELTER TENTS, MARCH.

*e.* At the command FORM FOR SHELTER TENTS, the messenger moves at double time behind the platoon to a position on the right of the right man of the front rank.

*f.* At the command MARCH, the first squad takes two steps forward and halts. All other squads face to the left in marching and continue marching in

quick time. Squad leaders move their squads into line, abreast of the squad or squad already on the line by giving the commands **RIGHT FLANK, MARCH; SQUAD, HALT**. Squad leaders may use their squad number preceding the preparatory commands.

*g.* At the commands **TAKE INTERVAL, MARCH** and **COUNT, OFF**, given by the platoon leader, the entire rank executes these movements as previously described. The base for these movements is the squad leader of the first (right) squad. The messenger and guide take interval to the right and do not count. The messenger is regarded as an odd-numbered man, the guide as an even-numbered man.

*h.* On the platoon leader's command, **MARK FRONT TENT POLE**, the odd numbers draw their bayonet with their left hand and thrust it into the ground, beside the outside of their left heel at the instep. The bayonet marks the left edge of the tent pole. Men not equipped with bayonets mark the place with left edge of their left heel. Odd-numbered men pitch tents with the even-numbered men to their left (Nos. 1 and 2; Nos. 3 and 4; etc.).

*i.* To assemble, the commands are **ASSEMBLE, MARCH; RIGHT, FACE; COLUMN OF TWOS (FOURS) TO THE RIGHT, MARCH**. These movements are executed as previously described. The guide and messenger resume their normal positions as soon as the platoon is re-formed in column. For the method of pitching shelter tents and displaying equipment, see **FM 21-15**.

## CHAPTER 7

### THE COMPANY

---

#### Section I. GENERAL

#### 89. General

a. The training received in the first (squad) and second (platoon) drill phases is combined into the third phase—company drill.

b. A company consists of a company headquarters and two or more platoons. For dismounted drill and ceremonies, the company headquarters personnel are attached to the platoons to equalize platoon strength without interfering with the permanent squad organization.

c. Posts for key personnel in company formations are—

- (1) *Company in line* (fig. 44).
  - (a) *Company commander*. Twelve steps to the front and center of the company.
  - (b) *Guidon bearer*. One step to the rear and 2 steps to the left of the company commander.
  - (c) *Platoon leaders*. Six steps to the front and center of their platoons.
  - (d) *Platoon sergeant (platoon guide)*. Normal interval to the right of the front rank squad leader.

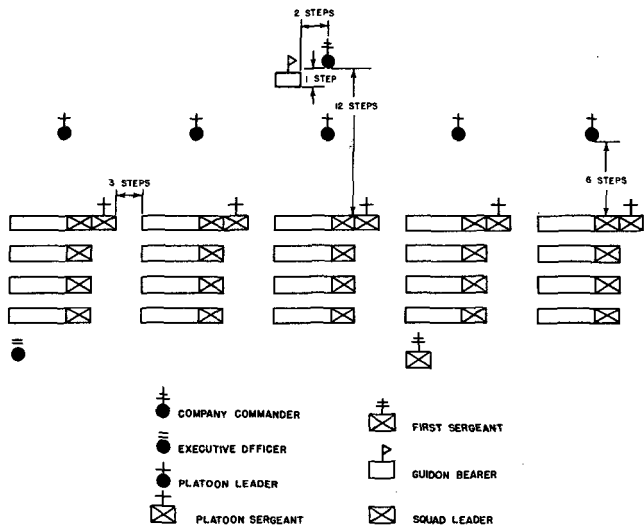

Figure 44. Company in line with platoons in line.

- (e) *Executive officer.* Normal distance to the rear of the left flank man, rear rank of the left platoon.
- (f) *First sergeant.* Normal distance to the rear of the left flank man, rear rank of the second platoon.
- (2) *Company in column with platoons in column for drill purposes (fig. 45).*
- (a) *Company commander.* Six steps in front of and centered on the leading platoon, or centered on the left flank of the company in a position to best control his unit. His distance from the flank should not exceed 12 steps (fig. 45). If the company commander moves to the left flank

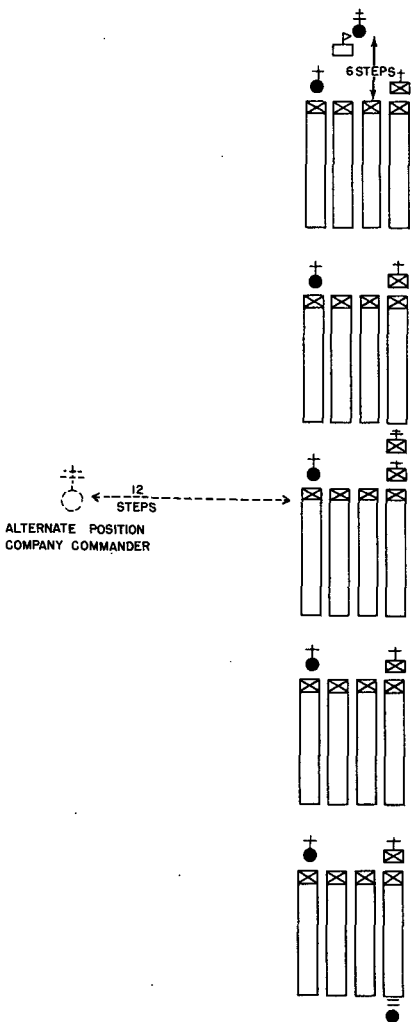

Figure 45. Company in column with platoons in column.

of the unit, the guidon bearer remains at the head of the column.

- (b) *Guidon bearer.* One step to the rear and 2 steps to the left of the company commander.
  - (c) *Platoon leaders.* Normal distance in front of the squad leader of the left file squad of their platoons.
  - (d) *Platoon sergeant (platoon guide).* Normal distance in front of the squad leader of the right file squad.
  - (e) *Executive officer.* Normal distance to the rear of the last man in the right file of the rear platoon.
  - (f) *First sergeant.* At normal distance to the rear of the last man in the right file of the second platoon, or as the company commander directs.
- (3) *Company in column with platoons in line (fig. 46).*
- (a) *Company commander.* Twelve steps front and center of the first platoon.
  - (b) *Guidon bearer.* One step to the rear and two steps to the left of the company commander.
  - (c) *Platoon leaders.* Six steps front and center of their platoons.
  - (d) *Platoon sergeants (platoon guides).* Normal intervals to the right of the right flank man of the first squad.
  - (e) *Executive officer.* At normal distance to the rear of the squad leader of the rear platoon.

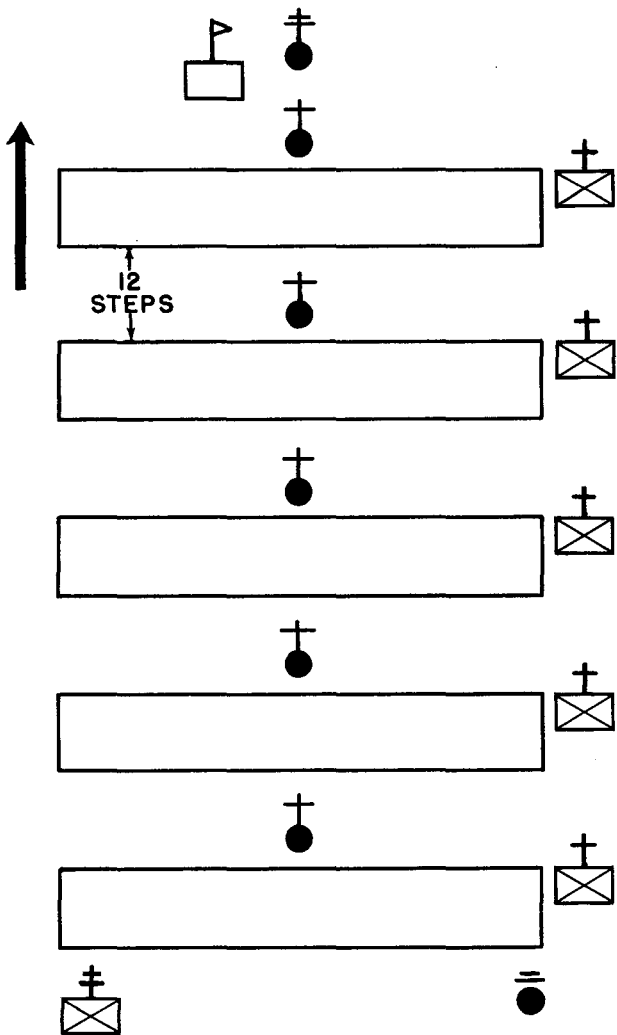

Figure 46. Company in column with platoons in line.



- (f) *First sergeant*. At normal distance to the rear of the left flank man of the rear platoon.
- (4) *Company in mass* (fig. 47).
  - (a) *Company commander*. Six steps to the front and center of the company.
  - (b) *Guidon bearer*. One step to the rear and two steps to the left of the company commander.
  - (c) *Platoon leaders*. Normal distance in front of the left file of their platoons.
  - (d) *Platoon sergeants (platoon guides)*. Normal distance in front of the right file of their platoons.
  - (e) *Executive officer*. Normal distance in rear of the last man of the right file of the left platoon.
  - (f) *First sergeant*. Normal distance in rear of the last man of the right file of the second platoon.

d. When the company commander directs that the company open and close ranks, aline, stack and take arms, close on the leading platoon, dismiss, and prepare for inspection, the movements are executed on the command of the platoon leaders, not on the directives of the company commander. The commander's directive describes the movement to be commanded by the platoon leaders.

e. The right platoon is base platoon for drill purposes.

## 90. Supplementary Commands

a. Except for movements in mass formation, platoon leaders repeat all preparatory commands of

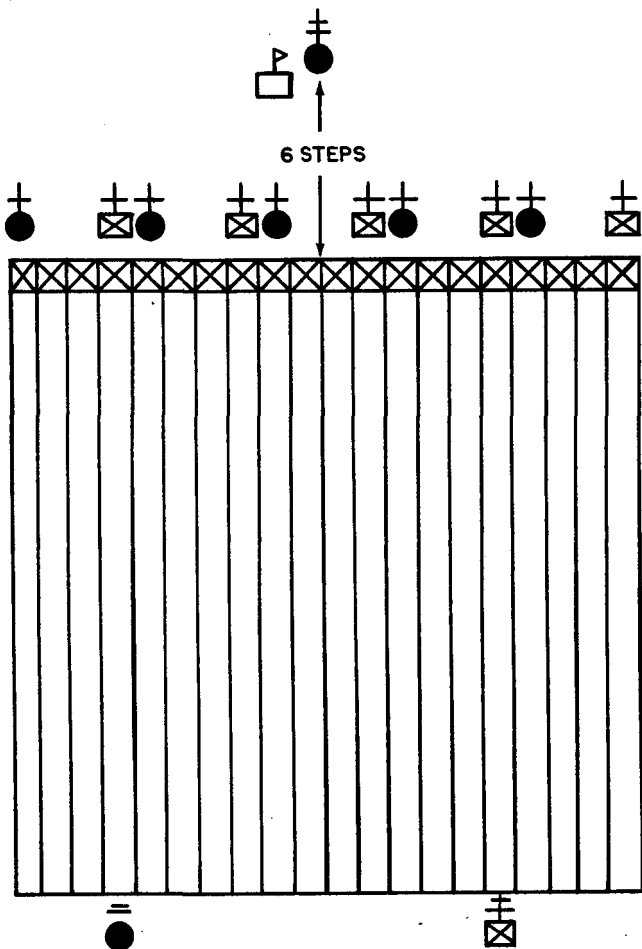

*Figure 47. Company in mass formation.*

the company commander, including the manual of arms, except when the command is COMPANY. In this case they come to attention and command PLATOON prior to the company commander's command of execution. The company commander allows enough time for the supplementary commands before giving the command of execution (par. 8).

*b.* To change the direction of a column, the leading platoon leader repeats the company commander's preparatory command, the other platoon leaders command CONTINUE THE MARCH, or STAND FAST, whichever is appropriate.

*c.* No supplementary commands are given for mass drill. They are given, however, when forming a mass or when forming a column for a mass. No supplementary commands are given for the company commander's commands AT EASE, REST, FALL OUT, or other combined commands.

## **Section II. COMPANY DRILL**

### **91. To Form the Company**

*a.* At the command FALL IN, the company is formed in line of platoons in line with 3-step intervals between platoons (fig. 44).

*b.* The first sergeant forms the company. He posts himself nine 30-inch steps in front of the center and facing the line where the front rank of the company is to form, and commands, FALL IN.

*c.* The platoon sergeants take their posts so that the company will be centered on and at proper distance from the first sergeant. They face their platoons, and allow for five 30-inch steps between platoons.

*d.* The first squad leaders take their posts relative to the platoon sergeant and the platoons form in two or more ranks with normal intervals as described in paragraph 80.

*e.* With armed troops, the first sergeant and platoon sergeants are at right shoulder arms.

*f.* The platoons are formed and the platoon sergeants receive the report from the squad leaders as described in paragraph 81. Each platoon sergeant faces about after receiving the reports.

*g.* When all platoon sergeants are facing to the front, the first sergeant commands **REPORT**. The platoon sergeants report in succession from right to left, "All present," "All present or accounted for" or "(so many) men absent." Salutes are exchanged in the same manner as in the platoon report.

*h.* All platoons having reported, the first sergeant commands **POSTS**. The platoon sergeants face about, face to the half left in marching, move to their posts by the most direct route, halt, execute order arms, and face about.

*i.* The first sergeant then faces about, salutes and reports to the company commander, "Sir, all present," "Sir, all present or accounted for," or "Sir, (so many) men absent." When his salute is returned, he faces about without command and moves directly to his post. The company commander is three steps from the first sergeant when the report is made, or 12 steps from the first rank of the company.

*j.* As the first sergeant faces about and moves to his post, the executive officer and platoon leaders

take their posts. The platoon leaders move around the left flank of their respective platoons.

*l.* Men required to make a report, salute while reporting and hold the salute until it is returned. The person receiving the report does not return the salute until the report is completed.

*l.* On the command AT CLOSE INTERVAL, FALL IN, the company forms with close interval between men, but the interval between platoons remains at 3 steps.

*m.* When the platoons are not organized into squads, the platoon sergeant commands INSPECTION, ARMS; PORT, ARMS; RIGHT SHOULDER, ARMS immediately after falling in, and calls the roll. Each man answers "Here" as his name is called, and comes to order arms.

## **92. To Dismiss the Company**

When the company is in line with platoons in line (fig. 44) at attention, it is dismissed in either of the following ways:

*a.* The company commander commands FIRST SERGEANT, DISMISS THE COMPANY. At the preparatory command FIRST SERGEANT, the first sergeant moves by the most direct route to a position three steps in front of the company commander and salutes. The company commander returns his salute and gives the command of execution, DISMISS THE COMPANY. Salutes are again exchanged. The company commander then falls out, and the executive officer, platoon leaders, and guidon bearer fall out at the same time. As the platoon leaders fall out, the platoon sergeants post themselves in front of their platoons. The first sergeant faces about and commands DISMISS YOUR PLA-

**TOONS.** The platoon sergeants salute. When the first sergeant returns the salute, they face about and dismiss their platoons by the commands **INSPECTION, ARMS; PORT, ARMS; DISMISSED.**

*b.* The company commander commands **DISMISS YOUR PLATOONS.** The platoon leaders salute. The company commander returns their salute and he, the executive officer, the first sergeant, and guidon bearer fall out. The platoon leaders then face about and command **PLATOON SERGEANT, DISMISS THE PLATOON.** At the preparatory command, each platoon sergeant posts himself three steps in front of his platoon leader and salutes. The platoon leader returns the salute and gives the command of execution, **DISMISS THE PLATOON.** Salutes are again exchanged and the platoon leader falls out. The platoon sergeant then faces about and dismisses the platoon as described in *a* above.

### **93. To Aline the Company**

*a.* The company is alined on the directive **DRESS RIGHT** from the company commander. When he gives this directive, all platoon leaders face about. The right platoon leader commands **DRESS RIGHT, DRESS,** and alines his platoon as described in paragraph 82*b*. When the alinement of the first rank of the right platoon has been verified, the platoon leader to the left of the right platoon commands **DRESS RIGHT, DRESS,** and alines from the flank of his platoon farthest from the right platoon. All other platoons aline their platoons in the same manner as the second platoon, waiting until the first

rank of the platoon to their immediate right has been alined.

*b.* When necessary, platoon guides step off the 3-step interval at the common GUIDE, VERIFY INTERVAL, given before the command DRESS RIGHT, DRESS.

#### **94. To Open and Close Ranks**

*a.* To open ranks, the company commander directs OPEN RANKS. All platoon leaders face about at this command. The right platoon leader commands OPEN RANKS, MARCH. At the command MARCH, the platoon opens ranks as described in paragraph 83. When the alinement of the first rank of the right platoon has been verified, the platoon leader to the left of the right platoon commands OPEN RANKS, MARCH, and alines his platoon on the first rank of the right platoon as outlined in paragraph 93. The commands and movements for succeeding platoons are identical to those for the second platoon, but are not executed until the first rank of the platoon to their immediate right has been alined.

*b.* To close ranks, the company commander directs CLOSE RANKS. All platoon leaders face about and command CLOSE RANKS, MARCH. The commands are given and executed beginning with the right platoon and proceeding in order to the left until all platoons have closed ranks, as described in paragraph 83.

*c.* To stack arms or ground equipment, the company commander directs, OPEN RANKS AND GROUND EQUIPMENT, or OPEN RANKS AND STACK ARMS.

## **95. To Form a Company in Column From Company in Line, and to Re-Form in Line**

*a.* With the company in line with platoons in line at the halt, the command to form in column is **RIGHT, FACE**. The platoon leaders repeat the preparatory command **RIGHT** and on the command of execution **FACE**, face to the right with the unit, then march by the most direct route to their posts at the head of their platoons.

*b.* The first sergeant takes his post behind the right file man of the second platoon at normal distance. The executive officer takes his post behind the last man in the right file rear platoon. The guidon bearer faces with the unit, then comes to port arms, and double times to his post at the head of the column.

*c.* To form in line with the company at the halt in column, the company commander commands, **LEFT, FACE**. The platoon leaders repeat the preparatory command and, on the command of execution, they face with the unit and, without command, march by the most direct route to their post six steps in front of and centered on their platoons. At the same time the executive officer, first sergeant, and guidon bearer resume their original posts as shown in figure 44.

## **96. Company in Column To Change Direction of March**

*a.* The commands are **COLUMN RIGHT (LEFT), COLUMN HALF RIGHT (LEFT), MARCH**.

*b.* When halted, the leading platoon leader repeats the company commander's preparatory command. Succeeding platoon leaders give the supplementary command, **FORWARD**. On the command of execution



**MARCH**, the leading platoon executes the movement as prescribed in paragraph 85, and succeeding platoons execute the movement on approximately the same ground as the leading platoon on command of the platoon leader.

*c.* While marching, the movement is executed as described in *b* above, except that succeeding platoon leaders command **CONTINUE THE MARCH**.

### **97. To Change Interval**

*a.* When in column, the company commander commands **CLOSE (EXTEND), MARCH**. All platoons execute the movement simultaneously as described in platoon drill (par. 84).

*b.* If executed while marching, the company commander commands **FORWARD, MARCH**, after the prescribed interval has been obtained.

### **98. To Form a Column of Twos and Re-Form**

*a.* To form a column of twos when the company is in column with platoons in column (fig. 45), the company commander gives the commands noted in paragraph 87 and allows time for the supplementary commands. These movements are commanded only from the halt.

*b.* The leading platoon leader repeats the preparatory command. Other platoon leaders command **STAND FAST**. The leading platoon executes the movement as in platoon drill on the company commander's command of execution. Other platoons execute the movement on their platoon leader's commands, given so as to follow with the normal 3-step distance between platoons.

*c.* Re-forming is executed simultaneously by all platoons on the company commander's command of execution as described in paragraph 87. Platoon leaders then march their platoons to the normal 3-step distance without a command from the company commander.

## **99. To Form a Company Mass When in Column**

*a.* With the company in column at the halt or while marching with close interval between files, the command is **COMPANY MASS LEFT, MARCH.**

*b.* At the preparatory command **COMPANY MASS LEFT**, when the company is at the halt, the leading platoon leader gives the command **STAND FAST**; the platoon leaders of succeeding platoons command **COLUMN HALF LEFT**. At the command **MARCH**, the leading platoon stands fast. The other platoons execute column half left then column half right on command of the platoon leaders, and move to the new position at close interval alongside the leading platoon. Each platoon is halted by its platoon leader so that its leading rank is abreast of the leading rank of the platoons already on line. These movements form the company in mass with close interval between files (fig. 47).

*c.* When the preparatory command **COMPANY MASS LEFT** is given during a march, the leading platoon leader commands **CONTINUE THE MARCH**. Platoon leaders of succeeding platoons give supplementary commands as noted in *b* above. Immediately after the company commander commands **MARCH**, the leader of the leading platoon commands **PLATOON, HALT**, and other platoon leaders complete the movement as described in *b* above.

## **100. To Aline a Mass Formation**

*a.* The company commander gives the command **AT CLOSE INTERVAL, DRESS RIGHT, DRESS.**

*b.* At the command of execution **DRESS,** the platoon leader of the right platoon moves by the most direct route to the right flank and verifies the alinement of as many ranks as necessary to assure proper alinement in a manner similar to verifying the alinement for the platoon (par. 82). When he has completed the verification, he returns to his position in the front rank. The company commander then commands **READY, FRONT.**

## **101. When in Mass Formation, To Change Direction of March**

*a.* The commands are **RIGHT (LEFT) TURN, MARCH; FORWARD, MARCH.** The right (left) flank man of the rank of guides and platoon leaders is the pivot for this movement. The movement is executed similarly to a platoon column movement except that the half step is continued until **FORWARD, MARCH** is given. This command is given after the entire company has changed direction and has arrived on line.

*b.* When at a halt, the company commander does not face the company to command **RIGHT (LEFT) TURN, MARCH,** but gives the command over his right shoulder. When marching, he turns and marches backward to give the command, then turns and marches at the half step in the new direction of march. He turns again and marches backward to command **FORWARD, MARCH,** then turns and marches forward.

*c.* In turning to the left, the left file is the base until FORWARD, MARCH is given. Then the dress is right.

### **102. To Form a Column From a Company Mass**

*a.* When at a halt, the command is COLUMN OF PLATOONS, RIGHT PLATOON, FORWARD, MARCH. At the preparatory command, the right platoon leader commands FORWARD, and the other platoon leaders command STAND FAST. At the command MARCH, the right platoon marches forward. All other platoons follow in column, executing column half right and column half left on the commands of the platoon leaders.

*b.* When in march, the commands are the same as in *a* above, except that DOUBLE TIME is given by the leading platoon leader instead of FORWARD, and the other platoon leaders command CONTINUE THE MARCH. On the command MARCH, the right platoon marches out in double time. Other platoon leaders command COLUMN HALF RIGHT, DOUBLE TIME, MARCH and COLUMN HALF LEFT, MARCH to bring the succeeding platoons into a column. With armed troops, the company commander commands PORT, ARMS before commanding this movement, unless at sling arms.

### **103. To Form a Column of Platoons in Line and Re-Form**

*a.* When at the halt with the company in column with platoons in column at normal interval, the company commander commands COLUMN OF PLATOONS IN LINE, MARCH. The platoon leader of the leading platoon commands STAND FAST. All

other platoon leaders command **COLUMN RIGHT**. Upon the command of execution, all platoons except the leading platoon execute a column right and a column left so as to obtain a 12-step interval from the platoon on the left when halted on line with the left platoon.

*b.* When marching, the leading platoon leader commands **CONTINUE THE MARCH** and **PLATOON, HALT** immediately after the command of execution **MARCH** by the company commander. All other platoons execute the commands and movements described in *a* above.

*c.* After all platoons are in position, the company commander commands **LEFT, FACE**. Platoon leaders face to the left with their platoons, then take their posts six steps in front of and centered on their platoons (fig. 46).

*d.* To re-form, the company commander commands **RIGHT, FACE; COLUMN OF PLATOONS, LEFT PLATOON, FORWARD, MARCH**. On the preparatory command, the left platoon leader commands **FORWARD** and the other platoon leaders command **STAND FAST**. At the command **MARCH**, the left platoon marches forward. The remaining platoons follow in column, executing column left and column right on command of the platoon leaders.

#### **104. To Correct Distance Between Platoons**

*a.* When the company is marching in column or at the halt, and it is desired to obtain the correct distance between platoons, the command is **CLOSE ON LEADING PLATOON**.

b. At this command, the leader of the leading platoon causes his platoon to take up the half step if in march, or stand fast if at the halt.

c. Succeeding platoons, if in march, are caused to continue the march, and then take up the half step as soon as the correct distance has been obtained. At the halt, succeeding platoon leaders march their platoons forward and halt them at the correct distance.

d. In march, the company commander commands FORWARD, MARCH, as soon as all platoons have obtained the correct distance and have taken up the half step. All platoon leaders repeat the preparatory command FORWARD.

A handwritten signature in cursive script, possibly reading "A. Smith", is written diagonally across the page.

## CHAPTER 8

# INSPECTIONS

---

### 105. General

The company is the basic unit for inspection. Battle group and higher commanders or inspecting officers inspect each company in its own area, or have it march to a designated place at a specified time for inspection. Under special conditions, an entire battle group is formed and inspected in one large formation.

### 106. Company Inspection

*a. Formation.* The company forms either in line of platoons in line (fig. 44) or in column of platoons in line (fig. 46). It forms in line of platoons in line for inspection of weapons and personal appearance, and in column of platoons in line for inspection of personal field equipment, including individual weapons, and personal appearance. When transportation is included in the formation, it forms in line 5 yards to the rear or as directed. The drivers remain with their vehicles. Transportation is inspected separately from the foot elements, or as directed.

*b. Procedures for Inspecting Weapons and Personal Appearance.*

- (1) With a company in line of platoons in line, the company commander directs **PREPARE FOR INSPECTION**. On this

directive, platoon leaders face about and command **OPEN RANKS, MARCH**, as prescribed in paragraph 94. After verification of the alinement, the platoon leaders march three steps in front of their platoons, halt, face to the left (right), and command **READY, FRONT**. After this movement has been completed, the right platoon leader takes one step forward, halts, faces to the right, and awaits the company commander. All other platoon leaders march forward, halt in front of the guide of their platoon, and execute a left face, positioning themselves three steps in front of the guide and facing the front; and await the company commander.

- (2) Ranks having been opened, the company commander commands **AT EASE**. He then inspects the company. During the inspection, officers, noncommissioned officers, and guidon bearers not in ranks come to attention at order arms as the company commander approaches. As soon as they have been inspected, they resume the position of at ease. The company commander may direct the executive officer or the first sergeant to join him and take notes during the inspection. When so directed, the executive officer or first sergeant places himself to the left rear of the company commander and accompanies him throughout the inspection. The company commander, beginning at the right of the line, makes a



minute inspection of the arms, equipment, dress, and appearance of the men. As he approaches each platoon, its leader brings the platoon to attention and salutes. The company commander returns the salute, inspects the platoon leader, moves around the left of the platoon leader, and halts in front of the first man to be inspected. At this time, the platoon leader executes about face and places himself to the right rear of the company commander and accompanies him throughout the inspection of the platoon.

- (3) During the inspection, squads not being inspected are given at ease by the platoon leader when directed by the company commander. The platoon leader calls the next squad to be inspected to attention at the appropriate time.
- (4) The inspection is made from right to left in front of and from left to right in rear of each rank.
- (5) The company commander moves from man to man by facing to the right in marching, taking two short, snappy steps so as to position himself in front of the next man to be inspected. He then executes a left face, facing the man.
- (6) Each man individually executes inspection arms when the company commander is directly in front of and facing him. This enables the company commander to observe the manual of the person being inspected.

As the company commander moves to the rear of the rank being inspected, each man, as he is approached, unfastens the snap on his bayonet scabbard, grasps his bayonet scabbard with his left hand, and moves the point of the scabbard slightly forward so that the company commander may remove the bayonet for inspection. The scabbard is held in this position until the bayonet has been replaced or, if the bayonet is not removed, until the company commander has moved to the position of the next man to be inspected.

- (7) To inspect a rifle, the company commander takes the rifle with his right hand by grasping it at the front hand guard just above the upper sling swivel. As soon as the rifle has been grasped, the individual being inspected releases the rifle and lowers his arms and hands smartly to his sides as in the position of attention. A suggested method of inspection that insures smartness, snap, precision, and a thorough inspection is as follows: Lower the rifle with your right hand, keeping the barrel to your right, and place the thumb of your left hand on the forward portion of the follower and glance into the barrel. The thumbnail will reflect enough light for the barrel and chamber inspection. After completing the barrel inspection, grasp the small of the stock with your left hand and raise the rifle to a position in front of your body, forearms hori-

zontal, barrel up and muzzle to your right. Move the rifle to your left, keeping the barrel horizontal, and inspect the upper portion of the rifle, beginning with the front sight and working to the heel of the butt (moving the rifle to the right). To inspect the lower portion of the rifle, release your left hand from the small of the stock, and regasp the rifle with your left hand just forward of the receiver on the lower hand guard. Immediately rotate the rifle to the left, regrasping it at the small of the stock with your right hand, palm up. The barrel is down and horizontal. Start this portion of the inspection at the toe of the butt and work left to the gas cylinder lock. As you complete the inspection, release your right hand from the small of the stock and apply downward pressure with your right hand on the sling at the small of the stock. Regrasp the rifle with your right hand at the front hand guard in the original manner. Return the rifle to the individual in the same position from which it was taken. The soldier takes the rifle with his left hand at the balance, immediately closes the bolt, pulls the trigger, and executes order arms.

- (8) When the company commander inspects the rifle without handling it, each man remains at inspection arms until the officer has moved to a position in front of and

facing the next man in line. He then comes to order arms.

- (9) Then men armed with the automatic rifle, carbine, and pistol execute inspection arms as prescribed in the manual for their weapon. The company commander removes the automatic rifle from the shoulder of the man being inspected, and inspects it in the most convenient manner. He replaces the weapon on the man's shoulder at the completion of the inspection. He inspects a carbine similarly to the M1 rifle. He takes a pistol with his right hand and inspects it in the most convenient manner. He then returns it to the individual being inspected. The men resume their original positions after their weapons have been inspected, as outlined above.
- (10) On completion of the inspection, the platoon leader calls the platoon to attention, takes his post three steps in front of the guide, and exchanges salutes with the company commander. The platoon leader then executes left face and commands, CLOSE RANKS, MARCH. When the ranks have been closed, he moves to a position six steps in front and center of his platoon, faces the platoon, and commands AT EASE. He then executes about face and assumes the at ease position.
- (11) When the company is inspected by an officer of a higher command, the company com-

mander, on the approach of the inspecting officer, commands **COMPANY, ATTENTION**. He then faces to the front, salutes the inspecting officer, and reports by saying, "Sir, Captain . . . . . reports . . . . . Company ready for inspection." The same procedure as outlined above is followed, substituting the words inspecting officer for company commander and company commander for company executive officer and first sergeant.

*c. Procedure for Inspecting Personal Field Equipment.*

- (1) The company forms in column platoons as described in paragraph 103 (fig. 46).
- (2) The company commander directs **PREPARE FOR INSPECTION OF EQUIPMENT**. On this directive, all platoon leaders face about and command **OPEN RANKS, MARCH**. All platoon leaders verify the alinement of their platoon from the right flank as described in paragraph 82. After they verify the alinement, the platoon leaders march three steps in advance of their platoon, execute left face, and command **READY, FRONT**. Then the first platoon leader commands **TAKE INTERVAL, MARCH**. On the command of execution, squads take interval as described in paragraph 66*c*. As soon as the proper interval has been obtained, the platoon leader commands, **UNSLING EQUIPMENT**.

- (3) At the command **UNSLING** equipment, each man draws his bayonet with his left hand and sticks it into the ground, outside of and against his left heel at the instep. This marks the line for the rear of his equipment when displayed. The men not armed with the bayonet mark the place with their left heel. Each man then lays his weapon on the ground, muzzle to the front, barrel to the left, butt near the toe of his right foot. He unslings his equipment and places it on the ground at his feet, belt to the rear, the pack in front of his toes.
- (4) The platoon leader then commands **DISPLAY EQUIPMENT**. Equipment is displayed in the interval to the left of each man and as prescribed in FM 21-15. When arrangement of the equipment is completed, each man resumes his original position in ranks and stands at ease.
- (5) As soon as the first platoon has completed taking interval, the other platoons take interval successively, covering the platoon to their front and preparing for inspection as described for the first platoon.
- (6) When the first platoon has completed preparation for inspection, the company commander starts inspecting the company as described in *b* above. He then directs the platoon leader to have the packs rolled and to assemble his platoon.
- (7) The platoon leader then commands **ROLL PACKS**. Each man assembles his equip-

ment, rolls his pack and, leaving his equipment in its position on the ground at his feet, assumes the position of at ease.

- (8) After the equipment is assembled, the platoon leader commands **SLING EQUIPMENT**. On this command, the men sling their packs, fasten their belts, take their weapons, and assume the position of order arms.
- (9) The platoon leader then assembles his platoon, closes ranks, and takes his post at the front and center of the platoon.
- (10) In units which have special combat equipment such as machineguns, mortars, and signal or command post equipment, the company commander directs **DISPLAY MACHINEGUN (MORTAR, or other) EQUIPMENT** after packs have been opened or after the individual inspection has been completed. The gun squads, under the direction of their leaders, break ranks and display their weapons and accessories for inspection as prescribed in the gun drill for the weapons. The gun or equipment is displayed in rear of its vehicle. Headquarters personnel display the fire control, communication, and any other combat equipment. When no transportation is present, the equipment is displayed three steps from the flank of each squad on the side from which the interval was taken. The rear of the equipment is placed on line with the rear edge of the individual field equipment.

## 107. Battle Group Inspection

*a.* For the inspection of individual weapons and appearance, the battle group is formed in a column of companies in line. For the display of equipment, it is formed in line with companies in column of platoons in line. Before the inspection, the battle group commander indicates whether heavy weapons and special equipment are to be displayed for inspection or left on their transportation.

*b.* When all companies are in the appropriate formation with all troops dismounted, the battle group commander directs **PREPARE FOR INSPECTION**. At this command, the company commanders face about and prepare their companies as described in paragraph 106, except that the companies are not put at ease.

*c.* Next, the battle group commander commands **REST**. He then inspects his staff and the color guard. When the battle group commander approaches the staff, the officers come to attention without command. When they have been inspected, they accompany the commander. As the commander approaches the color guard, the color bearer commands **COLOR GUARD, ATTENTION**. The color guard does not come to the position of inspection arms as the officers approach, nor does the commander actually inspect the color guard's weapons. The color guard may be dismissed as soon as inspected.

*d.* The battle group commander, beginning at the head of the column (right of the line), makes an inspection of the arms, dress, appearance (equipment), of the personnel of the several companies.



*e.* As the commander approaches each company, its commander faces toward his company and commands COMPANY, ATTENTION, faces to the front, salutes, and reports as in paragraph 106*b*(11). As soon as he has been inspected, he faces about and commands AT EASE. He then accompanies the battle group commander. The inspection proceeds as prescribed for company inspection.

*f.* The battle group commander may direct the company commanders to make the detailed inspection of the arms or other equipment of their companies. He may require officers of his staff to assist in the inspection, especially by checking equipment.

*g.* When a company has been inspected, the battle group commander may direct that it be dismissed or proceed with other duties.

*h.* When desired, the battle group commander may direct that companies not under inspection stack arms, fall out, and resume their places in time to be inspected.

*i.* When the battle group commander is not the inspecting officer, he prepares his battle group for the inspection and commands REST. On the approach of the inspecting officer, the battle group commander brings the battle group to attention, faces to the front, salutes, and reports. The inspecting officer inspects the battle group commander, who then commands REST. He accompanies the inspecting officer throughout the inspection of his battle group.

## CHAPTER 9

### THE BATTLE GROUP

---

#### Section I. GENERAL

##### 108. General

*a.* The battle group formations prescribed in this chapter are recommended as a guide for the corresponding units of the other arms and services.

*b.* The battle group does not drill by command of the battle group commander. Its companies form and march under the company commanders as directed by the battle group commander. When practicable, the formation and movement of the battle groups are made clear to unit commanders before starting the movement.

*c.* In ceremonies, the units remain at attention after the ceremony has started until at ease is ordered by the next higher commander of troops. Rest should not be given once the proceedings have started.

*d.* A unit may be presented to its commander or to a reviewing officer. When this is done, the presenting officer faces his unit and gives the command **PRESENT, ARMS**, then faces to the front and salutes. The members of the presenting officer's staff salute and complete their salute as he does.

*e.* The battle group commander gives his commands or orders orally, by prearranged signal, or

through staff officers or messengers who transmit them to the commander concerned.

### **109. Staff**

*a.* The commissioned staff of a commander forms in one rank, two steps to his rear at normal interval. The enlisted personnel of his staff form at normal distance to the rear of and covering the officers. Staff members usually are arranged from right to left in order of rank, the senior on the right; however, the commander may cause them to be arranged in any desired order.

*b.* When necessary to reduce the front of the staff for marching, it may be formed in as many ranks as necessary, maintaining normal distance between ranks, following the commander. The staff marches under the direction of the senior staff officer.

## **Section II. FORMATIONS AND MOVEMENTS**

### **110. Formation**

*a.* The battle group forms in line with companies in mass (fig. 48) and marches in column with companies in mass (fig. 49).

*b.* The attached units take their position as directed by the battle group commander. They conform to the formation and movements of the other units of the battle group.

*c.* The companies are designated numerically from right to left in line and from head to rear in column; that is, first company, second company, third company.

*d.* The terms "right" and "left" apply to right and left as the troops face.

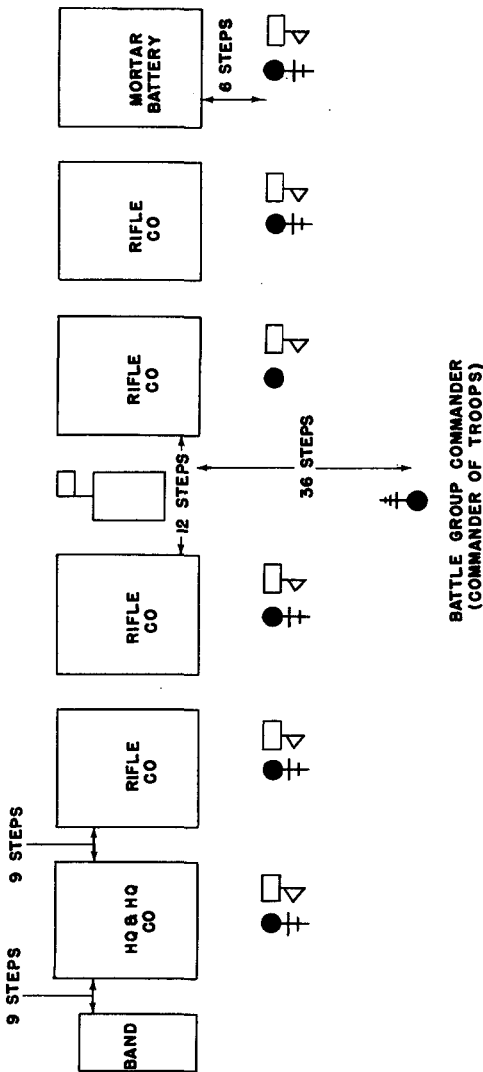
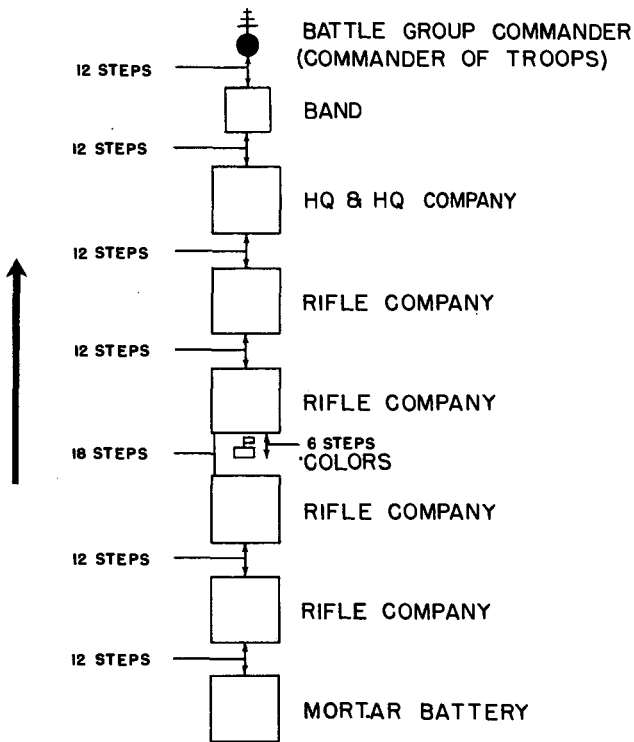

Figure 48. Battle group in line with companies in mass.



*Figure 49. Battle group in column with companies in mass.*

e. The designation "center company" indicates the center or the right center company, according to whether the number of companies is odd or even.

f. The commander of troops supervises the formation from such positions as enable him to correct alinements, intervals, and distances. He takes his post with his staff (less the adjutant) midway between the leading rank of unit commanders and the

post of the reviewing officer, facing the line of troops in time to receive the report.

### 111. To Form the Battle Group (for Ceremonies)

*a.* Before the ceremonies, the adjutant sees that the battle group position on the parade ground is marked with as many flags and markings as are needed (fig. 50). One flag is placed on each flank of the line on which the battle group is to form. The adjutant takes his initial post for the ceremony six steps to the right of the right flank marker facing down the line.

*b.* When a band is to participate in the ceremonies, the adjutant prearranges a signal or a specific time for adjutant's call to be sounded. The adjutant posts the left flank man of the band 9 steps to the right of the right flank marker as shown in figure 50 (3 steps to the right of the adjutant).

*c.* The companies are marched from either flank of the battle group position on the ready line in column of platoons in rear of the line on which the battle group is to form. The command of execution for their movement is so timed that they will step off at the first note of the music following adjutant's call. The line of march is far enough from the line on which the battle group is to form to permit alinement of the guides by the adjutant. When opposite its place in line, each company successively executes column left (right). As soon as the column movement has been initiated, the company commander orders **GUIDE ON LINE**. At this command the guide of the leading platoon moves out at a double time (at port arms) to the line marked by the flags.

*Q. W. H.*

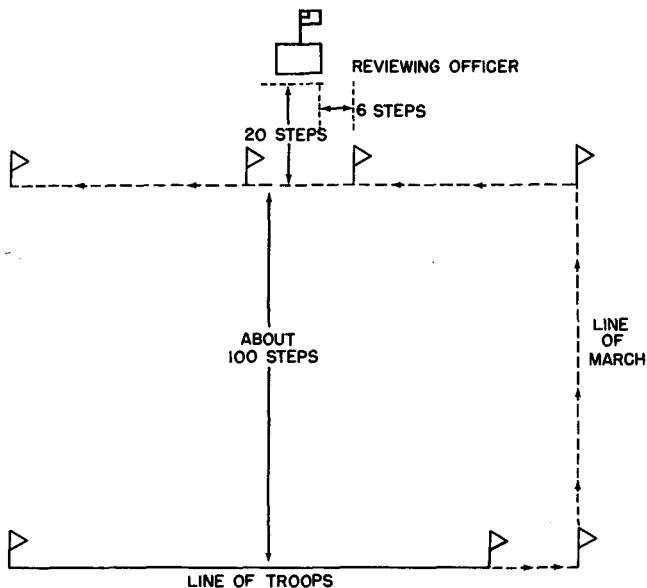

*Figure 50. Preparation for review.*

He halts, comes to order arms, and faces the adjutant. The guide marks the right of the company. The company commander then commands **COMPANY MASS LEFT, MARCH**. The command is timed so that the leading platoon can be halted on the line of guides. The remaining platoons successively move into position at close interval on the left of the leading platoon. If the company is at right shoulder arms, the company commander commands **ORDER, ARMS**. On the command **AT CLOSE INTERVAL, DRESS RIGHT, DRESS**, the leading man of the right file moves forward until his chest touches the guide's right arm. The company is then alined as pre-

scribed in paragraph 99. When the last company has reached its position on the line, the band stops playing. When all companies have executed ready front, the adjutant marches by the most direct route to a position midway between the line of company commanders and the battle group commander. He then halts and faces the battle group.

*d.* The adjutant then commands **GUIDES POST**. At this command, the guides execute a face to the left in marching from a halt and take their position in ranks.

*e.* The adjutant then directs **PRESENT ARMS**. Company commanders bring their units to present arms, starting with the center or right center company and continuing simultaneously toward both flanks. Individuals not armed with rifles execute the hand salute at the command **PRESENT, ARMS**, and end the salute at the command **ORDER, ARMS**. The adjutant then faces the commander of troops, salutes, and reports, "Sir, the battle group is formed."

*f.* The commander of troops returns the salute and commands, **POST**. (The members of the staff do not salute with the commander of troops when the troops are presented to him.) The adjutant passes to the commander's right and takes his post on line with the staff. The commander of troops then directs **ORDER, ARMS**.

*g.* When all units have come to order arms, the commander of troops faces the reviewing stand. The members of his staff march to their positions to his rear (fig. 51) at the commands of the senior staff officer.



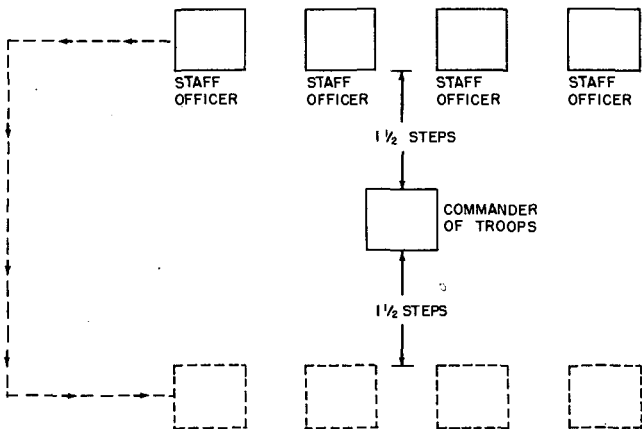

*Figure 51. Movement of the staff to the rear of the commander of troops.*

*h.* When the staff has reversed its position, the commander of troops faces the formation and, if the reviewing officer has not taken his post, directs at ease. If the reviewing officer has taken his post, he directs **PRESENT, ARMS**, faces the reviewing officer, and commands **STAFF, PRESENT, ARMS**. He and his staff present arms together. The ceremony then proceeds as outlined in paragraph 115.

## CHAPTER 10

### CEREMONIES

---

#### Section I. REVIEWS

#### 112. General

- a.* A review is a military ceremony held—
- (1) In honor of a visiting higher commander, official, or dignitary.
  - (2) For presenting decorations, awards, or honors to members or units of a command.
  - (3) To allow a higher commander, official, or dignitary to observe the state of training in a command.
- b.* A review may consist of the following six parts:
- (1) Formation of troops.
  - (2) Presentation and honors.
  - (3) Retreat (if scheduled).
  - (4) Inspection (passing around the troops).
  - (5) Decorations and awards (if scheduled).
  - (6) March in review.

*c.* A commander normally designates an officer of his command as commander of troops so that the commander may review his own troops or accompany a visitor reviewing the troops. The commander of troops is responsible for the preparation and organization of his troops for the review. Each unit should be sized uniformly with the tallest men in front and on the right. Whenever the national

anthem or To The Color is played as part of a ceremonial formation, the commander of troops faces the reviewing party and salutes.

*d.* The line on which the troops are to be formed and the route of march are marked or designated. Flags or appropriate markings are used to mark the post of the reviewing officer; another is placed six steps to the left of the reviewing officer to designate the point where EYES, RIGHT is commanded and executed, and still another is placed far enough to the right of the reviewing officer to designate the point where the command READY, FRONT is commanded (fig. 50).

### **113. Formation of Troops**

*a.* The battle group forms as described in paragraph 111. When two or more arms (infantry, artillery) are present in a review, the troops are arranged as ordered by the commander of troops. As a guide, units should be arranged from right to left in line with the slowest unit on the right (usually infantry) and progress to the most rapidly moving unit on the left.

*b.* Troops move to their positions on the ready line in the most convenient manner.

*c.* When commanders are mounted in vehicles, they dismount and take their posts as prescribed or as directed. They remain at their posts from the time their units arrive on the line until the command PASS IN REVIEW.

*d.* In motorized or mechanized units or elements, occupants of vehicles usually are required to form dismounted in a formation corresponding to that of

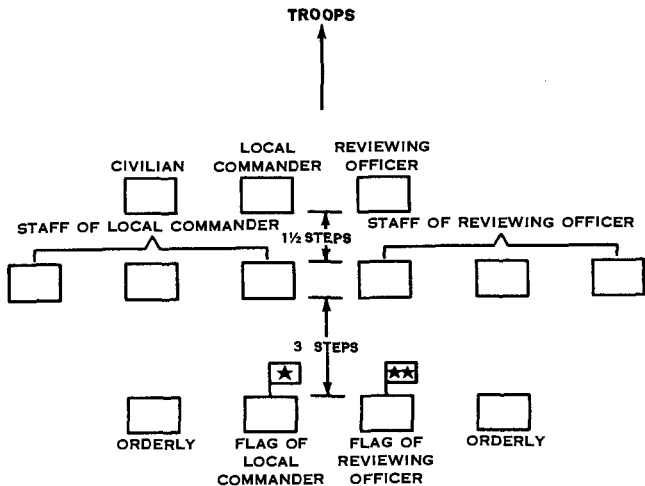

Figure 52. Reviewing party.

the other units in the review. At the command **PASS IN REVIEW**, they break formation, move at double time, and mount their vehicles.

#### 114. Reviewing Party

a. When the formation has been completed, the reviewing officer with his staff moves to his position opposite the center of the line of troops to receive the review (fig. 52).

b. The local commander (if not acting as commander of troops), distinguished persons invited to accompany the reviewing officer but not themselves receiving the review, staffs, and enlisted personnel take positions facing the troops. When an organization is reviewed before an inspecting officer or other person junior in rank to the local commander,

the junior takes position to the left of the local commander, unless the commander desires to accede the place of honor to him.

*c.* An officer from the local staff is designated to escort distinguished persons and to show them their positions. When a civilian receives the review, he takes position on the right of the local commander; if necessary, he is given a timely explanation of the ceremony.

### **115. Presentation and Honors**

*a.* The commander of troops brings the troops to present arms as soon as the reviewing officer has taken his post. When the grade of the reviewing officer entitles him to honors, the battle group color salutes at the command PRESENT, ARMS given by the commander of the company with which the color is posted. The battle group color is returned to the order at the last note of honors. The national color renders no salute.

*b.* Honors are given the reviewing officer, when his grade so entitles him, as prescribed in AR 600-25. The band or field music sounds the honors when the commander of troops faces the reviewing officer and salutes with his staff. The reviewing officer, the members of his staff, and all military spectators salute at the first note of the music and hold the salute until the music and gun salute are completed. When the honors are completed, the commander of troops and his staff end their salute. He then faces about and brings the troops to order arms. If the national anthem was played as part of the honors, or if the ceremony includes decorations and

awards, he orders at ease. The ceremony then proceeds with retreat (if scheduled), inspection, decorations and awards (if scheduled), and march in review. If the national anthem was not played as part of the honors, and decorations and awards are not scheduled, the commander of troops then faces the reviewing officer and, after a slight pause, he again faces the troops and directs present arms. He then faces the reviewing officer and commands STAFF, PRESENT, ARMS. He and his staff salute and the band plays the national anthem. The reviewing officer and his staff and all military spectators salute at the first note of the music. The commander of troops commands STAFF, ORDER, ARMS, without facing about. He then faces about and brings the troops to order arms and at ease. The ceremony then proceeds as scheduled. The inspection and decorations and awards may be omitted from the ceremony.

*c.* If the reviewing officer is not entitled to honors, the presentation proceeds as above except that the battle group color does not salute persons of lower rank than the battle group commander. As soon as the reviewing officer returns the salute of the commander of troops, the command is brought to order arms and at ease and the inspection follows. No music is played as part of honors, but if decorations and awards are not scheduled, the national anthem is played after the command has been presented to the reviewing officer.

*d.* When artillery is present in the review and when the commander of troops deems it practicable, a salute is fired in the manner prescribed in AR

600-25. The first gun is fired with the first note of the music. The detachment firing the salute rejoins its unit after the salute is fired. Use of the gun salute is limited to special occasions when it is desired to stage an especially impressive ceremony.

### **116. Inspection**

*a.* On completion of the presentation and honors, the reviewing officer and his party move forward and halt six steps in front of the post of the commander of troops. The two exchange salutes. Their staffs do not salute. The commander of troops then guides the reviewing party around the formation, beginning with the unit on the right of the line, passing in front of the line and then around the rear of the formation. In division-size reviews, the reviewing party passes between the line of battle group commanders and staffs and the line of company commanders. For battle-group-size reviews, the reviewing party passes between the line of company commanders and the line of troops. The commander of troops and the local commander march to the right of the reviewing officer. They are followed by the staffs of the commander of troops, of the local commander (if present), and of the reviewing officer. Each staff follows its own commander in column of files. If the commander of troops directs his staff not to accompany him, the senior staff officer gives the staff at ease after the reviewing party has departed and commands attention prior to the return of the reviewing party.

*b.* The reviewing officer may direct that his staff, flag, and orderlies remain at the reviewing officer's post so that only his aide accompanies him.

*c.* When the inspection is made in motor vehicles, the reviewing party enters the vehicles which drive up to the post of the reviewing officer after completion of the honors. In each vehicle, one seat on the right side (the side away from the troops during inspection) is left vacant. The vehicles move to the post of the commander of troops and stop. The commander of troops exchanges salutes with the reviewing officer, enters the reviewing officer's vehicle, and occupies the vacant seat. His staff officers occupy the vacant seats in the remaining vehicles. The orderlies and flag bearer remain at their posts. The vehicles proceed on the route of inspection as already described.

*d.* As the reviewing party approaches, each company commander (without facing about) commands attention and eyes right over his right shoulder. The guidon bearer executes present guidon (par. 60). The company commanders and platoon leaders execute eyes right and give the hand salute. All troops turn their heads and eyes to the right. As soon as the reviewing officer comes into their line of vision, they follow him with their eyes, turning their heads, until he reaches their front. At this point, the head and eyes of each man remain fixed to the front. The company commander commands ORDER, ARMS so that he and the platoon leaders terminate their salutes and the guidon bearer comes to order guidon when the heads and eyes of the troops reach the front. They remain at attention during the remainder of the inspection, except that for division-size reviews, each unit may be given at ease after the reviewing party has passed by, and again be brought



to attention as the reviewing party approaches the rear of the unit.

*e.* The band of an organization plays until the reviewing officer's inspection is completed.

*f.* The reviewing officer and those accompanying him salute the color only when passing in front of it.

*g.* The reviewing officer makes such general inspection of the command as he may desire while passing around the troops. A detailed inspection is not a part of a review ceremony.

*h.* The commander of troops salutes and halts after passing around the line and arriving at the right of the band, unless he is in a vehicle. The reviewing officer returns the salute and proceeds with his staff to his post. The commander of troops and his staff move directly to their posts facing the reviewing officer. When the inspecting party is in motor vehicles, a stop is made at the post of the commander of troops, where the commander of troops dismounts, exchanges salutes with the reviewing officer, and returns to his post. The members of his staff dismount and return to their posts at the same time. The vehicles then proceed to the post of the reviewing officer, where the members of the reviewing party dismount and return to their posts.

### **117. Decorations and Awards**

*a.* A review is held ordinarily on occasions of the presentation of decorations or of the decoration of the colors.

*b.* After the reviewing officer has inspected the troops and resumed his post, the commander of

troops, from his own post, commands or signals by prearranged signal: PERSONS TO BE DECORATED AND ALL COLORS, CENTER MARCH. At the command MARCH, the persons to be decorated and all colors move by the most direct route and take their posts as follows:

- (1) The persons to be decorated take positions as a single rank in the front and center of the command and 10 steps in front of the line of company commanders. They line up according to the rank of the decorations to be conferred, the highest ranking decoration on the right. Those receiving similar decorations take position according to their military rank within each decoration group.
- (2) The colors to be decorated are placed in a single rank five steps in front of the center of the line of persons to be decorated. They are alined in groups according to the rank of decoration to be bestowed, the highest ranking decoration on the right.
- (3) All other colors with the color guards are alined in a single rank five steps back of the center of the persons to be decorated. They take the same relative positions as their locations in the command.
- (4) The staff of the commander of troops, under command of the senior staff officer, executes right face and moves to the right far enough to provide clearance for the colors and persons to be decorated. The staff then halts and executes left face.

- (5) The commander of troops takes his post five steps in front of the center of the leading element. When the staff has cleared the necessary line of march, the commander of troops commands FORWARD, MARCH. At the command MARCH, the commander of troops, the persons to be decorated, and the colors advance, the band playing. The commander of troops marches directly toward the reviewing officer. The guide is center in all ranks. When the commander of troops has reached a point ten steps from the reviewing officer, he halts the group with the command DETACHMENT, HALT. He then salutes the reviewing officer and reports, "Sir, the persons (colors) to be decorated are present." The reviewing officer returns the salute and directs, PRESENT THE COMMAND.
- (6) The commander of troops passes around the right flank of the persons or colors to be decorated and proceeds directly to his post. On reaching his post, he brings the troops to present arms, faces about, and salutes, his staff saluting with him. If the national anthem has not been played as part of the honors, the band (field music) then plays it (or To The Color). On completion of the music, or after a slight pause if the national anthem is not played, the commander of troops and his staff terminate their salute, and the commander of troops brings the troops to order arms and has them stand at

ease. The persons to be decorated salute at the first note of the national anthem (or To The Color) and terminate the salute at the last note.

- (7) The reviewing officer, accompanied by his staff or certain members of his staff, advances by the most direct route to the right flank of the line of persons or colors to be decorated. When the reviewing officer approaches each individual, a staff officer reads the individual's citation. The staff officer pauses between reading citations to permit the reviewing officer to pin the medal on the left breast pocket of the individual or fasten the streamer on the staff of the guidon or color. As the reviewing officer approaches the guidon to be decorated, the guidon bearer executes present guidon so the reviewing officer may fasten the streamer. He executes order guidon after the guidon has been decorated. Color bearers lower the color to be decorated far enough for the reviewing officer to fasten the streamer. The color bearer gathers the color around the staff so it cannot touch the ground. He resumes the carry after the color has been decorated. When the last award has been presented, the reviewing party returns to its position in the reviewing stand and directs the commander of troops to march the command in review. At this time, the senior person decorated moves the persons decorated to a position in line with and six

steps to the left of the reviewing party. The colors return to their posts by the most direct route, the commander of troops moving to the right to allow this. After the colors have passed, he returns to his original position. The staff of the commander of troops then returns to its original position.

### **118. March in Review**

*a.* When the reviewing party is again in place after the inspection of the troops, or when the colors and staff have resumed their posts, the commander of troops commands **PASS IN REVIEW**.

*b.* At the command **PASS IN REVIEW**, the band is faced to the right and marched to a position that enables it to move straight out on the route of march without changing direction. If the band is not out of the way, the right company may run into it. The commander of the unit next to the band commands **RIGHT TURN, MARCH**. The band starts to play and marches forward at the command of execution, given by the commander of the company next to the band. Other units move out in succession and follow in column at the prescribed distance.

*c.* The band and each unit change direction at the points indicated in figure 53. The commander of each company in turn commands **LEFT TURN, MARCH; FORWARD, MARCH**, at each change of direction as stated in paragraph 101.

*d.* The commander of troops and his staff take position 12 steps in front of the band after the band has turned on the reviewing line as in figure 53.

*e.* The commander of troops and staff execute eyes right and salute when they arrive 6 steps from the

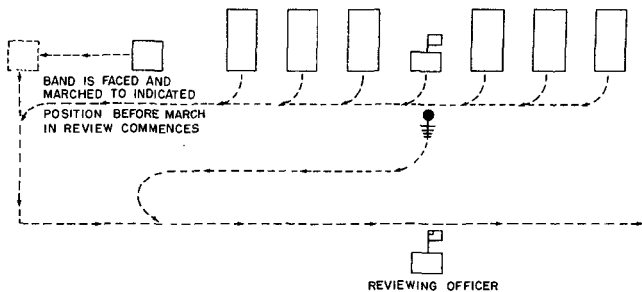

*Figure 53. Battle group review, companies in mass, marched in review in column of companies in mass.*

front of the reviewing officer. The commander of troops and staff end the salute when they have passed 6 steps beyond the front of the reviewing officer. The reviewing officer returns their salute. Other members of the reviewing party do not salute.

*f.* After saluting the reviewing officer, the commander of troops turns out of the column and takes his post on the reviewing officer's right side. The members of his staff accompany him and take their posts on the corresponding side of the reviewing officer's staff. When the rear element of his command has passed, the commander of troops faces the reviewing officer and salutes. The reviewing officer faces to the right and returns the salute. Then, accompanied by his staff, the commander of troops rejoins the command or dismisses his staff.

*g.* When the person reviewing the command is not mounted in a vehicle, the commander of troops and his staff (if mounted), turn out of the column after passing the reviewing stand and dismount preparatory to taking post. In such cases, the commander of

troops salutes the reviewing person before remounting and before rejoining his command.

*h.* When the commander of troops and his staff are in vehicles, the vehicles are parked on the side of the reviewing officer toward the direction of march and behind the lines occupied by the reviewing officer, the commander of troops, and their staffs.

*i.* When the reviewing officer is entitled to honors (AR 600-25) and the review is held before retreat, the drum major of the band, when 6 steps from the reviewing officer, causes the band to interrupt the march while the field music (or trumpet section of the band) renders the prescribed ruffles and flourishes only. The bandmaster and drum major execute and end their salutes at the point prescribed for the other commanders. When the band has passed the reviewing officer, it executes left turn 3 times to take a position in front of and facing the reviewing officer and at least 12 steps from the left flank of the marching troops. The band continues to play in position, facing the reviewing stand until the review has ended. It then follows the last unit at approximately 12 steps distance.

*j.* Troops march in review with the guide on the right. Each company commander, without turning his body, commands **EYES, RIGHT; READY, FRONT**. He gives the command **RIGHT** when he is 6 steps from the front of the reviewing officer, and **FRONT** when the last rank of the unit has cleared the reviewing officer by 6 steps. All troops except the right flank men execute eyes right without saluting.

*k.* At the command **EYES, RIGHT**, the company commander and platoon leaders execute eyes right

and give the hand salute. The guidon bearer executes present guidon and eyes right.

*l.* All end the salute at the command **FRONT**. The guidon is returned to the carry.

*m.* The reviewing party and all spectators salute the colors as they pass by. When the band is halted, colors pass between the band and the reviewing party, the band interrupts the march, sounds ruffles and flourishes only, depending on the rank of the reviewing officer, and resumes the march. As the color guard passes the reviewing officer, each man of the color guard except the right flank man, executes eyes right at the command of the senior color sergeant. When the grade of the reviewing officer entitles him to the honor, the battle group color salutes.

### **119. Retreat**

*a.* When a review is held at retreat, honors are given the reviewing officer as outlined in paragraph 115. At the completion of honors, the troops are brought to order arms and parade rest. The commander of troops then commands or signals **SOUND RETREAT** to the band or field music. He then faces the reviewing officer, and he and his staff stand at parade rest. At the conclusion of retreat, the commander of troops faces the troops and brings them to attention and present arms. He then faces the reviewing officer. At this time either the national anthem or *To The Color* is played. If the national anthem has been used as part of honors for a reviewing officer, or if decorations and awards are scheduled, then *To The Color* is played after retreat



is sounded. When the ceremony is held on an army post, the gun is fired at the last note of retreat, and as the national anthem (or To The Color) is played, the flag is lowered in the manner prescribed in SR 840-10-1 and FM 26-5.

*b.* The commander of troops salutes at the first note of the national anthem or To The Color. His staff, the reviewing officer and his staff, and all military spectators salute at the same time. The salute is held until the last note of the music. The commander of troops, on ending his salute, faces the troops and brings them to order arms. The ceremony then proceeds with an inspection and decorations and awards (if scheduled), and march in review.

*c.* If the reviewing officer has not arrived at his post by the scheduled time for retreat, the commander of troops proceeds with the retreat ceremony. He then presents the command after retreat and upon the arrival of the reviewing officer at his post.

*d.* Honors are not rendered between retreat and reveille, on Sundays, or on national holidays (except Memorial and Independence Days) unless, at the discretion of the officer directing the honors, the occasion requires an exception. The person or persons will be honored at the first available opportunity thereafter.

## **Section II. PARADES**

### **120. General**

*a.* The battle group parade is an alternate and more formal ceremony than a review (par. 112).

*b.* The appearance and movement of troops in formation are the primary considerations in a parade.

*c.* The preparation for and organization of troops for a parade are similar to those for a review. The distance between the troops and the commander for parade formations is greater than that for a review as the troop commander is also the reviewing officer.

### **121. Ceremonial Battle Group Parade**

*a.* After the battle group has been formed and aligned as shown in figure 48 and the guides have taken their posts, the adjutant, before presenting the battle group to the battle group commander, directs **PARADE, REST**. When the troops have executed parade rest, he commands **SOUND OFF**. The adjutant and the battle group commander, with his staff, stands at parade rest during the playing of Sound Off, the marching by of the band, and the sounding of Retreat.

*b.* At the command **SOUND OFF**, the band plays three chords while in place. At the conclusion of the third chord it moves forward, playing a march in quick time. It executes left turn to march across the front of the troops, midway between the adjutant and the line of troops. When the band has passed the left of the line it countermarches and returns over the same ground to the right of the line. After it has passed beyond the right of the troops, it executes right turn. When the entire band has passed beyond the front rank of the troops, it again countermarches and halts in its original position. When the band finishes the march, it again plays the Sound Off.

*c.* At an evening parade, immediately after the completion of Sound Off, the field music plays Retreat, and the retreat ceremony described in paragraph 119 follows. The adjutant brings the troops to attention and to present arms at the last note of Retreat. When all the troops have come to present arms, he faces the battle group commander and salutes. The battle group commander and staff salute at the first note of the national anthem (or To The Color), and end their salute at the last note.

*d.* At the completion of the national anthem (or To The Color) with the troops still at present arms, the adjutant again salutes the battle group commander and reports, "Sir, the parade is formed." The battle group commander commands, POST. The adjutant passes by the battle group commander's right and takes his post on the right side of the staff.

*e.* The battle group commander then directs ORDER ARMS and directs such movements in the manual of arms as he may desire. Officers, non-commissioned officers commanding platoons, the color guard, and the guidon bearers, having once executed order arms, remain in that position during the movements of the manual of arms.

*f.* The battle group commander then directs the adjutant, "Receive the report." The adjutant, passing by the battle group commander's right, advances toward the center of the battle group, halts midway between it and the battle group commander, and commands REPORT.

*g.* At the command REPORT, the company commanders, in succession from the right, salute and

report, "— Company, all present or accounted for." The adjutant returns each company commander's salute after the report is made and understood.

*h.* After receiving the reports, the adjutant faces the battle group commander, salutes, and reports, "Sir, all present and accounted for."

*i.* The battle group commander returns the salute, then directs, "Publish the orders." The adjutant faces the troops and commands **ATTENTION TO ORDERS**. He publishes the orders and then commands **OFFICERS, CENTER, MARCH**. He then faces about and takes his post with the battle group commander.

*j.* At the command **OFFICERS**, guidon bearers execute carry guidon.

*k.* At the command **CENTER**, company commanders and guidon bearers face to the center; officers commanding platoons move one step forward and face to the center; other officers move through the interval nearest to the center and take their posts in the column formed by the platoon leaders.

*l.* At the command **MARCH**, the band plays; officers and guidon bearers close to the center, halt, and individually face to the front; company commanders, when moving to the center, oblique to the front and close on a line four steps in advance of the line of guidon bearers. The guidon bearers close on their own lines, each taking his post in rear of his own company commander. All other officers close on the line of platoon leaders.

*m.* The officers and guidon bearers having closed and faced to the front, the senior officer commands **FORWARD, MARCH**. The center officer of the leading

rank is the guide. The officers and guidon bearers are halted with the leading rank six steps from the battle group commander. They salute the battle group commander, who returns the salute. The command **READY, TWO** is given by the senior company commander for the termination of the salute. The guidon bearers execute carry guidon at the same time.

*n.* The movements are executed at quick time to assure simultaneous execution by the officers and guidon bearers.

*o.* The battle group commander gives such instruction as he deems necessary and then commands **OFFICERS, POSTS, MARCH**.

*p.* At the command **POSTS**, all officers and guidon bearers face about.

*q.* At the command **MARCH**, they step off. The center officer of the leading rank is the guide.

*r.* The senior officer commands **OFFICERS, HALT**. He halts the leading rank three steps from the line of companies. He then commands **POSTS, MARCH**.

*s.* At the command **POSTS**, the officers and guidon bearers face outward.

*t.* At the command **MARCH**, the officers step off in succession at 4-step intervals and resume their posts. The guidon bearers step off with their company commanders. On resuming their posts, the guidon bearers execute order guidon. The music ceases when the last officer has taken his post. On resuming their posts, the officers and guidon bearers remain facing the troops and face about simultaneously at the command of the company com-

mander. Executive officers take their posts without command.

*u.* During the execution of *officers center* and *officers post*, all guidon bearers remain at carry guidon except when saluting.

*v.* The battle group commander then gives the command for the battle group to pass in review. The battle group passes in review on the commands and in the manner prescribed for a review. When the last company has passed, the ceremony is concluded.

*w.* The band continues to play while the companies are in march on the parade ground. After passing in review, the companies are marched to their respective areas and dismissed.

## **122. Street Parade**

*a.* For street parades, the troops are formed and march in the most convenient manner. Street parades may include transportation. Either towed or transported weapons add to the effect of a street parade. Cargo vehicles are included only when it is desired to increase the size of the display.

*b.* Practical formations for street parades are—

(1) Column of threes or fours.

(2) Two or more columns of threes or fours abreast.

(3) Mass formation.

*c.* The vehicles move in single column or column of twos, threes, or fours as the street width permits.

*d.* In long street parades, the rifles may be carried slung over the right shoulder.

### Section III. ESCORTS AND HONOR GUARDS

#### 123. Escorts of the Color

*a.* The battle group commander details a company to receive and escort the national color to its place. For this ceremony, the battle group color forms with the color guard at its post with the battle group.

*b.* The band moves straight to its front until clear of the line of company commanders, changes direction if necessary, and halts. The designated company takes position in column of platoons, 15 steps back of the band, with the color bearer back of the leading platoon. The escort then is marched without music to the battle group commander's office or quarters and is formed in line facing the entrance. The color bearer, preceded by the senior lieutenant and followed by a sergeant of the escort, obtains the color.

*c.* When the color bearer returns, followed by the lieutenant and the sergeant, he halts before the entrance, facing the escort. The officer places himself on the right and the sergeant on the left of the color bearer. The company commander brings the company to present arms, and the field music sounds *To The Color*. At the last note of the music, the company commander brings the company to order arms. The lieutenant and the sergeant salute, ending the salute at the commands of the company commander, then return to their posts.

*d.* The company again is formed in column, the band taking post in front of the column and the color bearer placing himself in the center of the space in rear of the leading platoon. The escort then is marched back to the battle group, the band

playing. The march is conducted so that the escort arrives at a point about 50 steps in front of the right of the battle group and then moves parallel to its front. The battle group commander takes his post in front of the center of the battle group. When the color arrives opposite the battle group commander, the escort is formed in line facing the battle group. The color bearer moves to a position six steps in front of the battle group commander and halts.

*e.* The battle group commander then faces the troops and brings the battle group to present arms. He then faces the color and salutes. The field music sounds *To The Color*. When the field music ends, he terminates his salute, faces the troops, and brings them to the order. Following the commands of the battle group commander, the escort is brought to present arms and order arms by its commander.

When the troops have been brought to the order, the color bearer moves to his post beside the battle group color bearer. The escort is faced to the right and, preceded by the band, marched to its place in line, moving around the left flank and back of the battle group. The band plays until the escort has passed the left of the line. It then returns to its post on the right, moving behind the battle group. The battle group may be given the command **REST** after the escort passes to the left of the line.

#### **124. Honor Guards**

*a.* Honor guards are employed to render personal honors to individuals of high civilian or military rank upon their arrival and/or departure from a military command. Honors are not rendered between retreat and reveille (AR 600-25).



*b.* The commander of the installation being visited, or his representative, is the host and takes part in the ceremony. He is briefed on the sequence of events so that he can advise the personage to be honored of actions to be taken during the ceremony.

*c.* Prior to the arrival of the personage, the honor guard is formed in line of companies or platoons with the colors centered. The band takes position to the right of and in line with the honor guard. If a saluting battery is present, its use will be governed by the provisions of paragraph 11*b*(3) and (4), AR 600-25.

*d.* Upon the first approach of the personage, the commander of troops brings the honor guard to attention. The host welcomes the personage on arrival and escorts him to the receiving line (if there is one) where greetings are exchanged. At the conclusion of the greetings, the host escorts the personage to a position 10 steps in front of and facing the commander of troops and takes position on his guest's left. When the personage and accompanying persons have halted in their positions, the commander of troops brings the honor guard to present arms and salutes. If the commander of troops has a staff, the staff salutes with the commander.

*e.* As the commander of troops executes the hand salute, the band begins the appropriate honors. If a firing battery is employed, the first round is fired simultaneously with the first note of the music and remaining rounds are fired at 2-second intervals. All military personnel in the vicinity of the honor guard formation, except those on security duty,

salute during the firing of the cannon salute and the rendering of honors (AR 600-25).

*f.* On completion of the honors, the commander of troops gives ORDER, ARMS, salutes, and reports, "Sir, the honor guard is formed." Staffs do not salute at this time.

*g.* If the personage does not desire to inspect the honor guard, it remains at attention until he departs.

*h.* If the personage indicates that he will inspect the honor guard, the commander of troops takes a position to his right and guides him through the inspection. The host takes a position to the right of the commander of troops. The band plays appropriate music until the inspection is completed.

*i.* The inspection begins at the right front of the band. The inspecting party passes along the front rank of troops. Ranks are not opened, nor do the individual members of the honor guard come to inspection arms or execute eyes right.

*j.* The members of the inspecting party render hand salutes or honors when they pass in front of the colors. When the inspecting party reaches the left front of the honor guard, it passes around the rear of the formation to a point at the right front of the band. When passing in rear of the colors, salutes will not be rendered by members of the inspecting party; however, if the visiting personage salutes all others will conform.

*k.* When the inspecting party reaches the right front of the band, the commander of troops halts, exchanges salutes with the personage, permits the personage and host to pass in front of him, and re-

turns to his post. The host escorts the personage back to the position in front of the honor guard. The commander of troops brings the honor guard to present arms. He and his staff salute the personage, who terminates the ceremony by acknowledging the commander's salute. The commander of troops commands ORDER, ARMS, and the honor guard remains at attention until the personage departs.

*l.* An honor guard ceremony upon departure of a personage is conducted in a manner similar to that described above. Generally, if the personage has inspected the honor guard upon his arrival, the host advises him that another inspection on departure is not expected.

#### **Section IV. COLORS AND STANDARDS**

##### **125. General**

*a.* The national and battle group flags carried by dismounted organizations are called the "national color" and the "battle group color." The term "color" implies the national color. The term "colors" implies the national color and battle group color.

*b.* The national and battle group flags carried by mounted or motorized organizations are called the "national standard" and the "battle group standard." The term "standard" implies the national standard. The term "standards" implies both the national standard and the battle group standard.

*c.* In garrison, when the colors (or standards) are not in use, they are kept at the office or headquarters of the commanding officer. They are escorted to and from his quarters or office by the escort com-

pany, or color (or standard) guard. In camp, when the colors (or standards) are not in use, they are displayed in front of the commanding officer's tent. When the weather permits, they are displayed uncased from reveille to retreat. From retreat to reveille and during inclement weather, they are cased and placed in the commanding officer's office, quarters, or tent.

*d.* The colors (or standards) are "cased" when they are furled and placed within protective covering.

*e.* The colors (or standards) may be carried in any formation in which two or more companies participate and in escorts, when ordered.

*f.* At battle group formations, the colors (or standards) are posted with the battle group. When the battle group formation is broken up, as in drill or field exercises, the colors (or standards) join the battle group commander or are dismissed as directed.

*g.* The manual for individual colors and distinguishing flags for general officers is the same as that for organizational colors. Salutes by such colors or flags are executed from the carry as prescribed for a battle group color.

*h.* The national color (or standard) renders no salute.

## **126. Salutes by Battle Group Color (Standard)**

*a.* The battle group color (or standard) salutes in military ceremonies while the national anthem or *To The Color* is being played and when rendering honors to its battle group commander or to an individual of higher rank, but in no other case.

b. When marching, the battle group color (or standard) salutes when 6 steps from the front of the person entitled to the salute. It is returned to the carry when 6 steps beyond him.

c. When passing in review, the color (or standard) guard executes eyes right at the prescribed saluting distance upon the command of the senior sergeant. The commands are: EYES, RIGHT; and READY, FRONT. When the grade of the reviewing officer entitles him to the honor, the battle group color (or standard) salutes at the command RIGHT and is returned to the carry at the command FRONT. The man at the right flank of the color guard does not execute eyes right. In those organizations which do not execute eyes right in passing in review, the standard guard omits this compliment. Where applicable, the battle group standard salutes at the command of the senior, who commands STANDARD, SALUTE. The return to the carry is made at the command, CARRY, STANDARD.

## **127. Color Guard**

a. The color guard consists of two sergeants and two experienced privates selected by the battle group commander. Usually they are men with long and honorable service who have an exceptionally soldierly appearance. A position on the color guard is one of honor. Members of the color guard, when not engaged in the performance of their duties, join their organizations. The senior sergeant carries the national color and commands the color guard. He gives the necessary commands for the movements

and for rendering the colors. The battle group color is placed on the left of the national color.

*b.* The color guard is formed and marched in one rank at close interval, the color bearers in the center. The color guard does not execute to the rear march, about face, or fix bayonets.

*c.* At the command of the senior sergeant, the privates of the color guard present arms or, if armed with the pistol, execute the hand salute on receiving and parting with the colors. After having parted with the colors, the guard is brought to order arms by command of the senior remaining member who is placed as the right flank man of the guard.

*d.* Having received the colors, the senior sergeant conducts the guard to its proper position before the color company. Having parted with the colors, the guard is dismissed by the senior sergeant.

*e.* At drills and ceremonies in which the colors are to participate, except escort of the color, the colors are received by the color company before the formation of the battle group. The color company receives the color as follows: The color company is formed, its commander facing the front. The color guard, guided by the senior sergeant, approaches from the front and halts at a distance of ten steps from the company commander. The company commander then faces his company and brings it to present arms, faces the colors, and salutes. He then faces his company and brings it to order arms. The privates of the color guard execute present and order arms with the color company. The color guard then is marched by the senior sergeant directly to its post. It takes its post on the left when the company is in line or mass and

in rear when the company is in column. When the color company joins the battle group, the color guard takes its appropriate post in the battle group formation.

*f.* When in formation, the color guard executes at ease and rest with the color company, keeping the pikes of the colors vertical. It executes right shoulder, order, and present arms with the color company, but remains at order during execution of the manual of arms.

*g.* During an inspection, the color guard does not come to the position of inspection arms as the inspecting officers approach, nor do the inspecting officers actually inspect the color guard's weapons.

*h.* When it is desired to dismiss the color guard at the conclusion of a drill or ceremony, it proceeds from its position and halts ten steps in front of and facing the commander of the color company. The commander of the color escort company commands, **PRESENT, ARMS** and **ORDER, ARMS**. On the command **ORDER, ARMS**, the color guards come to right shoulder arms. The color guard then escorts the colors to the office, quarters, or tent of the commanding officer. The color guard is dismissed from organizations smaller than a company (funeral escort) in a similar manner.

*i.* In a campaign, before an engagement of the battle group, the colors are stored as directed by the commanding officer.

*j.* After the playing of the national anthem or *To The Color*, during the presentation of decorations and awards, the troops are brought to order arms. On this command, by the commander of troops, the

color guard returns to the position of right shoulder arms.

### **128. Movement of the Color Guard to the Rear, Right, or Left**

*a.* To face the color guard to the rear (fig. 54), the command is **COLORS, REVERSE, MARCH**. At the command **MARCH**, each man steps off simultaneously and executes the following movements: No. 1 takes 2 steps forward, faces to the left in marching, takes 1 full step and 3 half steps, faces to the left in marching, and takes 2 steps in the new direction. No. 2 faces to the left in marching and faces to the left while marking time. No. 3 takes 1 step forward, faces to the right in marching, takes 2 half steps, faces to the right in marching, and takes 1 step in the new direction. No. 4 takes one step forward, faces to the right in marching, takes 1 full step and 3 half steps, faces to the right in marching, and takes 1 step in the new direction. Nos. 2, 3, and 4 mark time after completing their movements until all men are abreast, then step off together or halt as the case may be.

*b.* The color guard faces to the right (left) by executing a right (left) turn and inclining to the left (right) until they are centered on the element to their front.

### **129. Position of the Color at the Order**

At the order, rest the heel of the pike on the ground and touching the outside of your right footgear opposite the ball of your right foot. With your right hand at a convenient place on the pike, clasp it with your thumb, back of your hand to the right, and hold it in a vertical position.



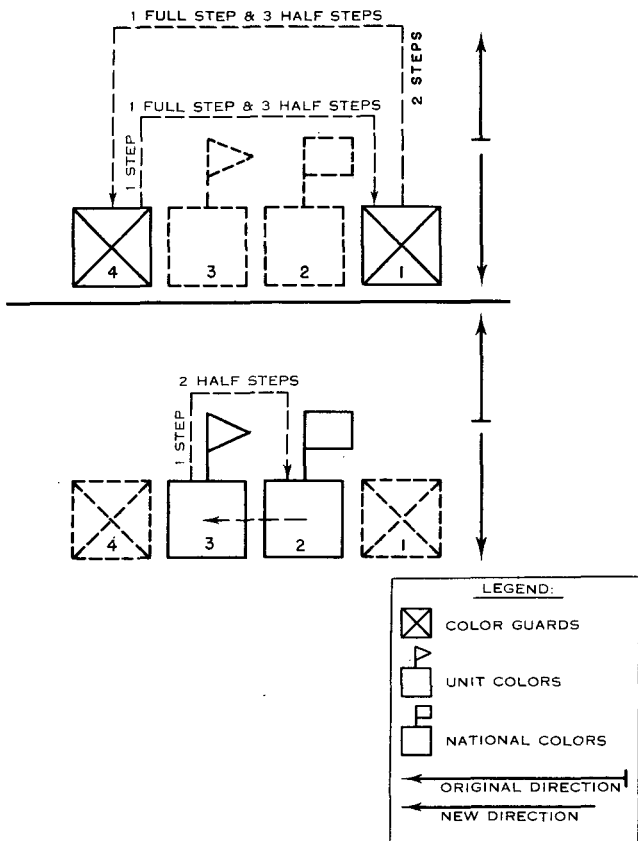

*Figure 54. Movements of the color guard to the rear.*

### **130. Position of the Color at the Carry**

At the carry, rest the heel of the pike in the socket of the sling, grasp the pike with your right hand at shoulder height, with the pike inclined slightly to the front.

### **131. Position of the Color at Parade Rest**

*a.* Execute parade rest with the color similar to parade rest with the rifle, but keep the pike vertical.

*b.* Resume the order at the command ATTENTION.

*c.* Execute the order and parade rest with the color company.

### **132. Position of Battle Group Color at Color Salute**

Assume this position from the carry by slipping your right hand up the pike to the height of your eyes, then lowering the pike by straightening your arm to the front. When the battle group color salutes with troops who execute present arms from the order, assume the position of carry at the command ARMS, and then execute the color salute.

## **Section V. FUNERALS**

### **133. General**

*a.* Military funerals are divided into the three following classes:

- (1) With chapel service, followed by the march to the grave or place of local disposition with the prescribed escort.
- (2) Without chapel service, the funeral procession forming at the entrance to (or at a point within a reasonable distance of) the cemetery.

(3) With graveside service only.

*b.* A full military funeral normally consists of the following elements:

(1) Band.

(2) Escort appropriate to the grade of the deceased, including a firing squad and bugler (AR 600-25).

(3) Colors.

(4) Clergy.

(5) Caisson and active pallbearers.

(6) Caparisoned horse (if the deceased was a member of a mounted unit).

(7) Honorary pallbearers.

*c.* The services of an Army chaplain are provided unless the family of the deceased (or its representative) requests some other clergyman to officiate. A civilian clergyman may be substituted for or act in conjunction with the Army chaplain. The desires of the family are given the fullest consideration possible in the selection of elements involved, but the funeral is conducted as prescribed in this manual.

*d.* The commanding officer or his representative assists in making the funeral arrangements and supervises the conduct of the funeral.

*e.* When honorary pallbearers are desired, they are selected by the family of the deceased or its representative, or when the family or its representative so desires, by the commanding officer.

*f.* At a military funeral, all persons in the military service in uniform attending in their individual capacity will face the casket and execute the hand salute at any time when the casket is being moved, while the casket is being lowered into the grave, dur-

ing the firing of the volley, and while taps are being sounded. Honorary pallbearers in uniform will conform to these instructions when not in motion. Military personnel in civilian clothes, in the above cases and during the service at the grave, will stand at attention, uncovered, and hold the headdress over the left breast. During the prayer, all personnel bow their heads.

*g.* When arms are presented at the military funeral of a person entitled to personal honors, the prescribed ruffles and flourishes are sounded. This is followed immediately by the national anthem (or To The Color), or the march prescribed for the grade of the deceased, except when arms are presented at the close of the benediction at the grave (AR 600-25).

*h.* The word "chapel" is interpreted to include the church, home, or other place where services are held, exclusive of the service at the grave.

*i.* The word "casket" is interpreted to include a receptacle containing the cremated remains of the deceased.

#### **134. Funeral With Chapel Service**

*a.* Before the beginning of the service, the funeral escort is formed in line facing the chapel. The band forms on the flank toward which it is to march.

*b.* Members of the immediate family, relatives, and friends of the deceased are requested to enter the chapel and be seated before the casket is taken in. Members of the immediate family and relatives occupy front seats on the right of the chapel.

*c.* The conveyance bearing the remains to the chapel should arrive in front of the chapel a few

moments before the time set for the service. Since the casket normally is covered with the national color, the escort is called to attention and the escort commander salutes as the conveyance passes. When all is in readiness to move the casket into the chapel, the commander of the escort brings the escort to **PRESENT, ARMS**. At the command **ARMS**, the band renders honors, if appropriate, followed by a hymn. At the first note of the hymn, the casket is removed from the conveyance by the active pallbearers and carried between the ranks of honorary pallbearers, if any, into the chapel. As soon as the casket enters the chapel, the band ceases to play. The escort then is brought to the order and given at ease.

*d.* When honorary pallbearers are present, they are formed in two ranks, each facing the other, forming an aisle from the conveyance to the entrance of the chapel. At the first note of the music, and while the casket is being borne between the ranks of honorary pallbearers, they uncover or salute as prescribed in paragraph 133. They then follow the casket in column of twos and occupy pews to the left front.

*e.* When the casket has been placed upon the church truck, the active pallbearers form behind the honorary pallbearers and are seated behind them. When there are no honorary pallbearers, the active pallbearers follow the casket in column of twos and occupy the pews to the left front.

*f.* The funeral director (or in his absence, the chaplain's assistant) moves the church truck as previously arranged by the chaplain. If there is no church truck, the active pallbearers carry the casket as instructed by the chaplain before the service.

*g.* After the chapel service, the active pallbearers follow the honorary pallbearers or, if no honorary pallbearers are present, they follow the chaplain in column of twos as the casket is moved to the entrance of the chapel. The honorary pallbearers again form an aisle from the entrance of the chapel to the caisson or hearse and uncover or salute as prescribed. When the casket has been placed on the caisson, they enter their conveyances. When marching, they form columns of files on each side of the caisson, the leading member of each column opposite the front wheels of the caisson.

*h.* The casket, followed by the family group, is moved to the entrance immediately behind the honorary pallbearers and active pallbearers. As soon as the honorary pallbearers have taken their positions, the active pallbearers carry the casket to the caisson and form in column of twos behind it. If the honorary pallbearers do not march, the active pallbearers form files on each side of the caisson, the leading member of each column opposite the front wheels of the caisson. The family group remains at the chapel entrance until the honorary pallbearers have broken ranks to enter their conveyances or have taken their positions at the caisson. The members of the family group then are guided to their conveyances.

*i.* When the casket appears at the entrance of the chapel at the conclusion of the service, the funeral escort and band repeat the procedure as prescribed for entering the chapel. The band ceases playing and the escort is brought to the order when the casket has been secured to the caisson.

*j.* The procession is then formed in the following order:

- (1) Band.
- (2) Escort, including colors, firing squad, and bugler.
- (3) Honorary pallbearers, if riding in cars.
- (4) Clergy.
- (5) Caisson and honorary pallbearers, if walking.
- (6) Active pallbearers.
- (7) Caparisoned horse (par. 133*b*(6)).
- (8) Family.
- (9) Patriotic or fraternal organizations.
- (10) Friends.

*k.* When the procession has been formed, the band and escort are put in march by the escort commander. The elements in rear conform. The procession marches slowly to solemn music. When there is considerable distance from the chapel to the grave, the escort, after leaving the chapel, may march at ease in quick time. The escort is brought to attention in the vicinity of the grave. The band does not play while the escort is marching at ease.

*l.* As the procession approaches the grave, the marching elements move directly to their predesignated positions. The band and military escort are formed in line behind and facing the foot of the grave. The other marching elements are placed as near as practicable to the grave. The firing squad is placed so that it will not fire directly over the mourners.

*m.* As soon as the caisson is halted, the honorary pallbearers are formed in two ranks, forming an

aisle extending from the caisson toward the grave. When the grave is too near the road to permit this formation, they take their position at the grave before the removal of the casket from the caisson.

*n.* When all is in readiness to move the casket from the caisson, the escort commander commands **PRESENT, ARMS**. At the command **ARMS**, the band renders honors, if appropriate, followed by a hymn. At the first note of the hymn, the active pallbearers remove the casket from the caisson. At the first note of **Taps**, and until its last note has sounded, military personnel attending in an individual capacity and honorary pallbearers uncover or salute.

*o.* Preceded by the chaplain and the cemetery representative or funeral director, the active pallbearers bear the casket between the ranks of honorary pallbearers to the grave and place it on the lowering device. They remain in place facing the casket. They raise the flag from the casket and hold it in a horizontal position, waist high, until the conclusion of **Taps**. As soon as the casket has passed, the honorary pallbearers face toward the grave and follow the casket in column of twos, followed by the family and friends.

*p.* When the casket has been placed over the grave, the band ceases playing and the escort is brought to the order. The commander of the escort then commands **PARADE, REST**. The escort executes parade rest with the officers and men inclining their heads.

*q.* When the escort has been brought to parade rest, the chaplain conducts the graveside service. At the conclusion of the benediction, he moves two steps to the side or rear.



*r.* When the service has been completed, the commander brings the escort to attention. He then commands: ESCORT LESS FIRING SQUAD, PRESENT, ARMS; FIRING SQUAD, FIRE THREE VOLLEYS. The firing party fires three volleys of blank cartridges, assumes the position of present arms on the command of the noncommissioned officer in charge, and remains in this position until the conclusion of Taps. At the command ARMS, the bugler takes position at the head of the grave and sounds Taps immediately following the last volley.

*s.* At the conclusion of Taps, the rifles of the firing squad are locked, and the entire escort then is brought to the order. The active pallbearers then fold the flag as prescribed in SR 840-10-1. They do not let it touch the casket which is on the ground. It then is handed to the superintendent of the cemetery or his representative for disposition as prescribed by SR 840-10-1. The band and escort are put in march in quick time by the escort commander. The other elements conform. At the first halt, the rifles of the firing squad are unloaded and inspected.

*t.* On the return march, the band does not play in the immediate vicinity of the grave. In a small cemetery, this is considered as within the cemetery limits. In a large cemetery, this is considered as a distance from the grave so short that the playing would detract from the solemnity of the occasion. Care is exercised to avoid disturbing other funeral processions or services which may be passed on the route of march.

### **135. Funeral Without Chapel Service, but With Procession and Graveside Service**

*a.* When the escort for a military funeral forms at or near the entrance to the cemetery, the officer in charge supervises the transfer of the casket from the hearse to the caisson.

*b.* When honorary pallbearers are present, they are formed in a single line facing the caisson. The leading honorary pallbearer is opposite the front wheel on the side opposite to that on which the hearse is halted. When more than 12 honorary pallbearers are present, they are formed in double rank.

*c.* While the casket is being transferred from the hearse to the caisson, the escort is brought to present arms and the band plays an appropriate air. The honorary pallbearers uncover or salute as described in paragraph 133. During the transfer of the casket, the family and friends remain in their conveyances.

*d.* The funeral procession then is formed and proceeds as prescribed.

### **136. Graveside Service**

*a.* For this type of funeral (without chapel service) all elements of a military funeral except the caisson and caparisoned horse are present and used as described in paragraph 134. However, if troops are not conveniently available or if the family desires to eliminate other elements, the following are used:

- (1) Clergy.
- (2) Active pallbearers.
- (3) Firing squad.
- (4) Bugler.

*b.* The military elements participating in a graveside service are in position before the arrival of the remains.

### **137. Cremated Remains**

*a.* When the remains are cremated and the ashes interred with military honors, the provisions of paragraphs 134 through 136 with necessary modifications will govern.

*b.* For all phases of the funeral where the cremated remains are carried by hand, one man is detailed to carry the receptacle containing the ashes. Four men are detailed as flagbearers. When the receptacle is carried from the conveyance into the chapel, from the chapel to the conveyance, or from the conveyance to the grave, the flagbearers follow the receptacle. The flag is folded as prescribed in SR 840-10-1 and carried by the leading flagbearer on the right.

*c.* When the receptacle has been placed on the stand before the chancel of the chapel or when it is placed in the conveyance, the flag, folded as prescribed, is placed beside the receptacle. When the caisson is equipped with a casket container for the receptacle, the open flag is laid upon the container as prescribed for a casket.

*d.* When no hearse or caisson is used, suitable transportation is provided for the receptacle bearer and the flagbearers.

*e.* In cases where the remains are conducted to a crematory and the ashes are to be interred with military honors at a later time, the ceremony consists only of the escort to the crematory. Arms are

presented as the remains are borne into the crematory. The firing of volleys and the sounding of Taps are omitted. When the funeral ceremony is held at the crematory and when no further military honors are anticipated, the volleys are fired and Taps is sounded at the discretion of the commanding officer.

### **138. Ceremony Before Shipment of Remains**

When the remains of a deceased officer or soldier are moved to a railway station or other point for shipment to a distant place for interment or final disposition, funeral services, modified as necessary, may be carried out as prescribed in paragraphs 133 through 135. When no further military honors are anticipated at the place of interment or final disposition, the volleys are fired and Taps sounded at the discretion of the commanding officer. When military honors are anticipated at the place of final disposition, the firing of volleys and the sounding of Taps are omitted.

### **139. Cannon Salute**

*a.* When the funeral of a general officer on the active or retired list who was entitled to a cannon salute takes place at or near a military installation, minute guns equal to the number to which the officer was entitled (AR 600-25) will be fired at noon of the day of the funeral.

*b.* Immediately after the remains have been lowered into the grave (upon completion of the benediction), a cannon salute corresponding to the grade of the deceased (AR 600-25) will be fired, followed

by three volleys of artillery, guns firing simultaneously, or three volleys of musketry.

#### **140. Participation of Aviation**

When aviation participates in a military funeral, it is timed so that the airplanes appear over the procession while the remains are being borne to the grave.

#### **141. Participation of Fraternal or Patriotic Organizations**

*a.* At the request of the immediate family of the deceased, or its representative, fraternal or military organizations of which the deceased was a member may be permitted to take part in the funeral service.

*b.* When the ritual is military or semimilitary, the rites begin immediately upon the conclusion of the Army religious service. When the ritual contains the firing of three volleys of musketry and the sounding of Taps, the military firing squad and bugler are used. The sounding of Taps concludes the funeral services.

*c.* Nonmilitary rituals by fraternal organizations are held at the conclusion of Taps. The military escort is marched promptly and quietly away from the site of the grave at the end of the military ceremonies.

#### **142. Duties of the Chaplain**

*a.* The chaplain takes his position in front of the chapel before the arrival of the remains. He precedes the casket when it is borne from the conveyance into the chapel, from the chapel to the conveyance, and from the conveyance to the grave.

While the remains are being placed on the caisson or in the hearse, he stands uncovered at the rear and to the side facing the caisson or hearse. When he is wearing vestments, he may, at his discretion, proceed directly from the chancel to the sacristy (vestry) at the conclusion of the chapel service and divest, joining the procession before it moves from the chapel.

*b.* When the procession is formed at the entrance to the cemetery or other point and the chapel service is omitted, he stands uncovered at the rear and to the side facing the caisson while the remains are being transferred from the hearse to the caisson. In cold or inclement weather, he may remain covered except when reading such parts of the service as require him to be uncovered.

### **143. Preliminary Arrangements**

The officer in charge of a military funeral, the commander of the escort, and the superintendent of the cemetery or his representative visit the places involved and make careful arrangements before the time set for the funeral. They determine the positions at the grave for the various elements of the funeral, and make arrangements for traffic control.

### **144. Floral Tributes**

*a.* In the absence of a funeral director, the officer in charge assisted by the chaplain and such details as may be required, arranges all floral tributes in the chapel and at the grave. He calls the commanding officer for necessary transportation for the prompt transfer of floral tributes from the chapel to the grave. The conveyance bearing the floral tributes

is loaded promptly at the conclusion of the chapel service. It precedes the funeral procession, moving as rapidly as practicable to the site of the grave. The funeral procession does not move from the chapel until the conveyance carrying the floral tributes has cleared the escort.

*b.* The officer in charge is responsible for removing cards and making a record that gives a brief description of the floral piece pertaining to each card. After completion of the funeral services, the cards and records are turned over to a member of the family of the deceased.

#### **145. General Rules for Ceremonial Firing**

*a.* For ceremonial firing, the firing squad consists of not more than seven riflemen and one NCO in charge. The squad is formed in line before firing.

*b.* Rifles are loaded while locked.

*c.* Except during firing, after the rifles have been ordered loaded and locked, they remain loaded and locked without command until the command UNLOAD or INSPECTION, ARMS.

#### **146. To Load**

*a.* With the unit halted in any formation, the command is WITH BLANK CARTRIDGES, LOAD. At the command LOAD, each rifleman faces half right and moves his right foot 12 inches to the right to a position that gives him a firm and steady stance. He raises or lowers the rifle, and drops it into his left hand, grasping it at the balance. His right hand is at the small of the stock, the muzzle held in the air at an angle of 45° (fig. 55). He then loads his rifle as prescribed in FM 23-5.

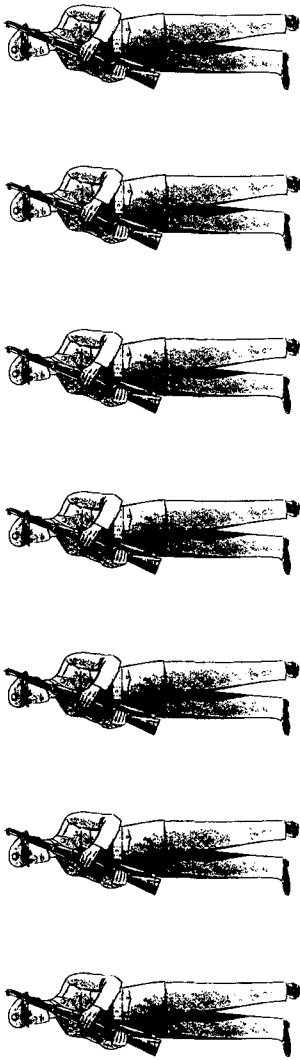

*Figure 55. Ceremonial firing: position of load.*



b. For instruction in loading, the command is **SIMULATE, LOAD**. The movements of loading are executed except that the handling of the cartridges is simulated.

#### **147. To Unload**

Being in any formation, the command is **UNLOAD**. At the command, the position of load is taken, and the rifle is unloaded as prescribed in FM 23-5. The chamber is closed and the ejected clips are returned to the belt. The rifle is then brought to the order.

#### **148. To Fire by Volley**

a. Being in the firing formation with the rifles loaded, the command is **READY, AIM, SQUAD, FIRE**. For ceremonial purposes blank ammunition is used. At the command **READY**, the firing squad assumes the position of load, if not already in that position. At the command **AIM**, the rifle is raised with both hands to a position  $45^{\circ}$  from the horizontal. The rifle rests in the palm of the left hand and the butt is placed and held firmly against the shoulder. The left hand is well under the rifle, grasping it at or in front of the balance, the right hand grasping the small of the stock. The right elbow is at the height of the shoulder. The right cheek is pressed firmly against the stock as far forward as possible without straining. The left eye is closed, the right eye looking over the rear sight. The safety lock of the rifle is pressed to its forward position with the trigger finger. As a safety precaution, a firing squad may find it necessary to swing the muzzle of their weapons to the right or left from their front to

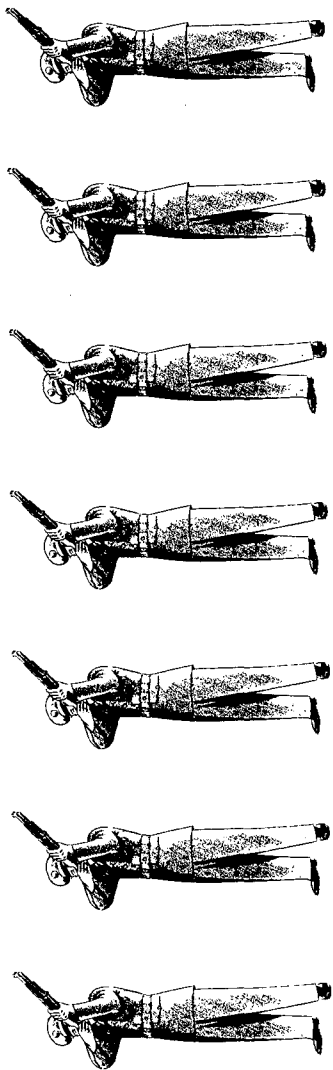

Figure 56. Ceremonial firing: position of fire (modified).

avoid firing over the attendants assembled at the graveside (fig. 56). At the command FIRE, the trigger is squeezed quickly. *The rifle is then lowered to the load position and reloaded.*

b. To continue the firing, the command is AIM, SQUAD, FIRE. Each command is executed as prescribed above.

c. To cease firing, the command is CEASE FIRING. Rifles not already at the position of load are brought to that position.

# CHAPTER 11

## MOUNTED DRILL

---

### Section I. GENERAL

#### 149. General

*a.* The drill described in this chapter provides for the orderly formation and movement of vehicles in ceremonies. The formation may be modified to conform to local conditions.

*b.* The term "motorized units" includes armor and mechanized units and the term "company" includes battery and troop.

#### 150. Dismounted and Motorized Troops Participating in Ceremony

When both marching and motorized troops take part in a ceremony, it is desirable to have the vehicles move as a unit separately from the foot troops. The formation, speed of movement, and the method of march are determined by the commander.

#### 151. Disposition of Weapons

Members of motorized units fall in at formation for drills and ceremonies in the same manner as dismounted units. When mounted in vehicles, unless at rest or at ease, they sit at attention and hold their weapons in the position of order arms. They grasp the hand guard of the rifle just above the lower band.

When armed with the carbine, they grasp it just below the front band. The drivers, assistant drivers, and others specifically designated, place their weapons in the boots or racks provided or in any other safe and appropriate place.

### **152. Manual of Arms**

*a.* When dismounted, execute the manual of arms for foot troops. Do not execute the manual in the vehicle.

*b.* When armed with the rifle or carbine, take up the positions as prescribed in paragraph 151.

*c.* When passing in review, all troops except drivers or those armed with the rifle or carbine, fold their arms and hold their elbows shoulder high with right arm uppermost.

*d.* The officers in vehicles execute the hand salute. The men in vehicles, unless in charge of a unit or detachment, do not salute.

### **153. The Commander**

The mounted drill commander usually is in front of the base element. From this position, he leads the unit in the desired direction and at the desired speed. He may, however, move to where he can best observe and supervise his unit, leaving its guidance to another officer.

### **154. Base**

*a.* In mounted drill, any element or vehicle may be designated as the base. Ordinarily, the base vehicle follows the commander or conforms to his movement. The other elements or vehicles regulate and guide on the base vehicle.

*b.* In mass, the right front vehicle normally is the base vehicle. When not in mass, the right vehicle usually is the base vehicle in line, and the leading vehicle usually is the base vehicle in the column.

*c.* Base elements adjust their movements to prevent interference with the other elements during changes in the formation.

### **155. Intervals and Distances**

*a.* In mounted drill, the intervals and distances may be varied to meet local conditions of terrain. The normal intervals and distances for halted vehicles are shown in figure 57. Moving vehicles should maintain a distance of not less than 12 yards and an interval of not less than 5 yards.

*b.* On the command or signal OPEN or CLOSE, the intervals or distances are increased or decreased.

*c.* The intervals or distances are not closed when coming to a halt unless the unit is commanded or signaled CLOSE.

### **156. Speed**

*a.* In mounted drill, the leader and base elements move at a uniform rate of speed, which usually is not more than 15 miles per hour.

*b.* Other elements, when necessary, vary their speed gradually during movements to conform with the base or to complete movements.

### **157. Formations**

*a.* The formations described in this chapter can be adapted to all motorized units, regardless of type or number of vehicles. When practical, the vehicles are formed in columns or lines of approximately 20 vehicles formed as a single unit. For tactical forma-

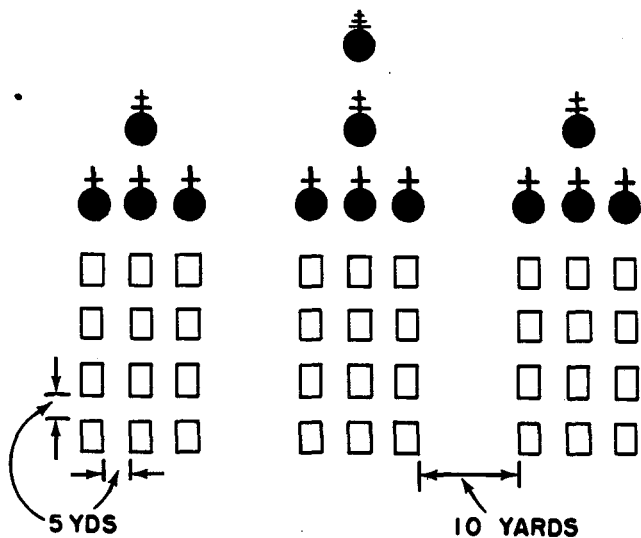

### ① LINE OF MASSES

Figure 57. Vehicles in mass formation.

tions, see the manual for the particular type of unit concerned.

b. The formations are as follows:

- (1) *Column.* In this formation, the elements or vehicles are placed one behind the other and the right edges of the vehicles are alined (fig. 58).
- (2) *Line.* In this formation, the elements or vehicles are abreast and the front edges of the vehicles are alined (fig. 57①).
- (3) *Mass.* A unit formed with two or more columns abreast constitutes a mass. Masses may be grouped as follows:

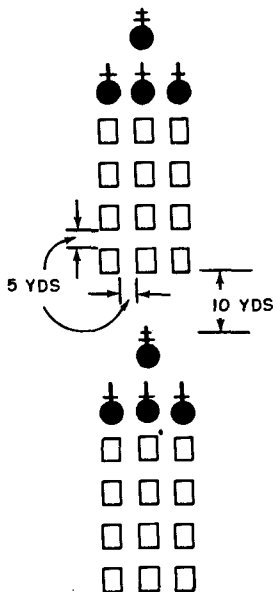
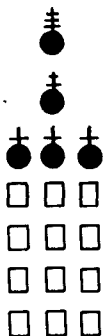

② COLUMN OF MASSES

Figure 57—Continued.



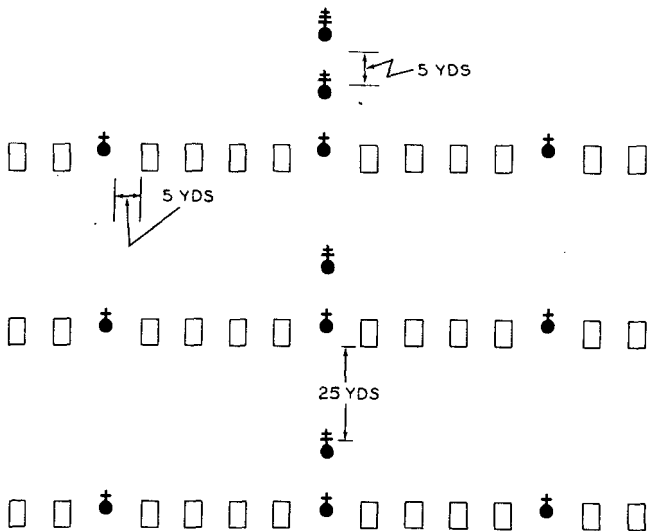

Figure 58. Battalion in column with companies in line.

- (a) *Line of masses.* Masses abreast with 10-yard interval (fig. 57①).
- (b) *Column of masses.* Masses placed one behind another with 10-yard distance between companies (fig. 57②).
- (c) *Line of battalions in line of masses.* Battalions in line of masses abreast with 20-yard interval between battalions.
- (d) *Line of battalions in column of masses.* Battalions in column of masses abreast with 20-yard interval between battalions.
- (e) *Column of battalions in line of masses.* Battalions in line of masses, placed one behind another, with distances of 20 yards between battalions.

(f) *Column of battalions in columns of masses.* Battalions in column of masses, placed one behind another, with distances of 20 yards between battalions.

c. Mass formations may be used for ceremonies or instruction by companies or larger units.

### **158. Vehicles Massed as a Separate Unit**

When vehicles are massed as a separate unit, they are placed with respect to the foot troops as directed by the unit commander. The distance and interval between the vehicles and the marching troops is stated by the unit commander. The normal distance and interval between halted vehicles is the same as prescribed in paragraph 155.

### **159. Vehicles Accompanying Dismounted Troops**

When forming with foot troops, vehicles form 5 yards in rear of the rear line of men. The interval between the vehicles depends on the frontage of the unit with which they are forming, but is never less than 5 yards (fig. 59).

### **160. Formation at Vehicles**

To form at the vehicles, from any formation, the commands are—**AT YOUR VEHICLES, FALL IN.** At the command **FALL IN**, the men move to their assigned vehicles and form as shown in 1, figure 60. When there are more than five men, they form two or three ranks with normal distance as illustrated in 2, figure 60. When there are more than 15 men, the number of men per rank may be increased. Artillery sections form as prescribed in service-of-the-piece manuals.

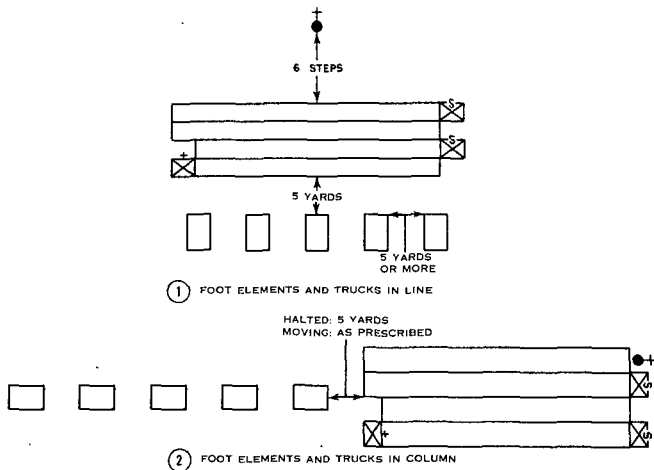

*Figure 59. Formation of vehicles accompanying dismounted troops.*

## 161. Load Vehicles

At the command **LOAD VEHICLES**, the men in formation at the vehicles load their weapons and equipment under the direction of their leader. When the loading is completed, the men designated to ride mount the vehicle and take their seats and sit at attention.

## 162. Unload Vehicles

With the men in the vehicles, the command is **UNLOAD VEHICLES**. At this command, the men dismount and remove their weapons and equipment under the direction of their leader. The unit re-forms without command as described in paragraph 161.

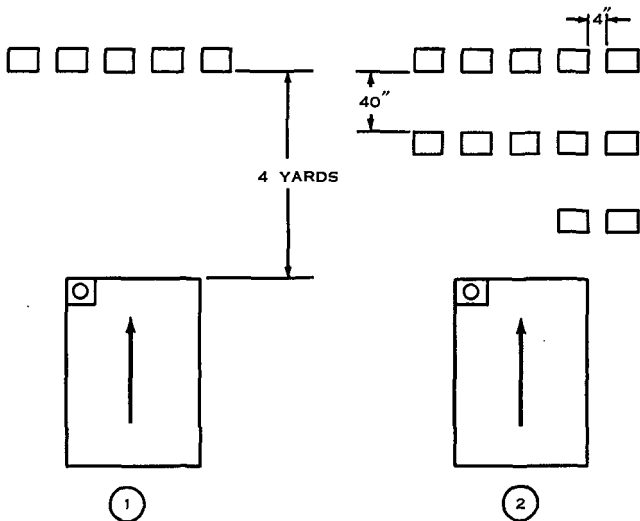

Figure 60. Formation at vehicles.

## Section II. MOVEMENT OF VEHICLES

### 163. General

*a. Formations While Moving.* The rules for drill of vehicles are the same regardless of their number, because the vehicles of a unit normally form in line or in column. Complicated maneuvers are not executed.

*b. Instruction Before Ceremonies.* The formation and movements are explained before the ceremonies. To attain orderly formations and movements at ceremonies, it may be necessary to drill in the following essential movements:

- (1) Movement forward in line and columns.
- (2) Movement from column to line and from line to column, including changes in direction.

- (3) Movement into a mass formation from a single column.
- (4) Movement in mass formation, including changes in direction.
- (5) Forming a single column from a mass formation while moving or from a halt.

#### **164. To Start Engines**

The vehicles are started at the command or signal **START ENGINES**. They are kept running until the command or signal **STOP ENGINES** is given. When the vehicles are halted during ceremonies, the engines are kept running unless the halt is prolonged.

#### **165. To Move Forward**

The commander gives the warning signal **FORWARD** and his vehicle moves out. The other vehicles move forward at the designated distance (or interval). They are alined on and follow the base vehicle.

#### **166. To Halt**

The commander orders his driver to signal **HALT**. The driver then slows down and halts the commander's vehicle. The other vehicles close to the prescribed distance (interval) and halt.

#### **167. To Form a Column or Line**

In any formation except line or column, the commander places his own vehicle at the base position and signals **ASSEMBLE**. Then he extends his arm horizontally and points in the direction of the line or column on which the vehicles are to form. The other vehicles then move to position in column or line at the prescribed distance or interval.

*a. To Form a Column From a Line.*

- (1) The commander signals COLUMN, and orders his driver to give the signal indicating whether the movement is to be made on the right, left, or front. Then he has his vehicle move in the new direction. The remaining vehicles, in succession from the right (left), turn and follow at the prescribed distance.
- (2) In armor units, the column formations are executed from any line formation by successive movements of the next elements within a unit to their positions in rear of the forward moving base. The base is followed alternately by the next lower element on its right and left. These elements begin their movement by changing their formations, if required, and moving by the most direct route to their new positions.

*b. To Form a Line From a Column.*

- (1) The commander signals LINE and orders his driver to give the signal indicating the direction the movement is to be made (right, left, or front). Then he has his vehicle move in the desired direction. The other vehicles form in line on the commander's vehicle (figs. 61 and 62).
- (2) In armor units, a formation in line is attained from any column by a fan-shaped deployment toward both sides of the base. The next element within the unit in rear of the base moves to the right of the base, the third to the left of the base, and so on alternately (fig. 61). These elements move by the most direct route without

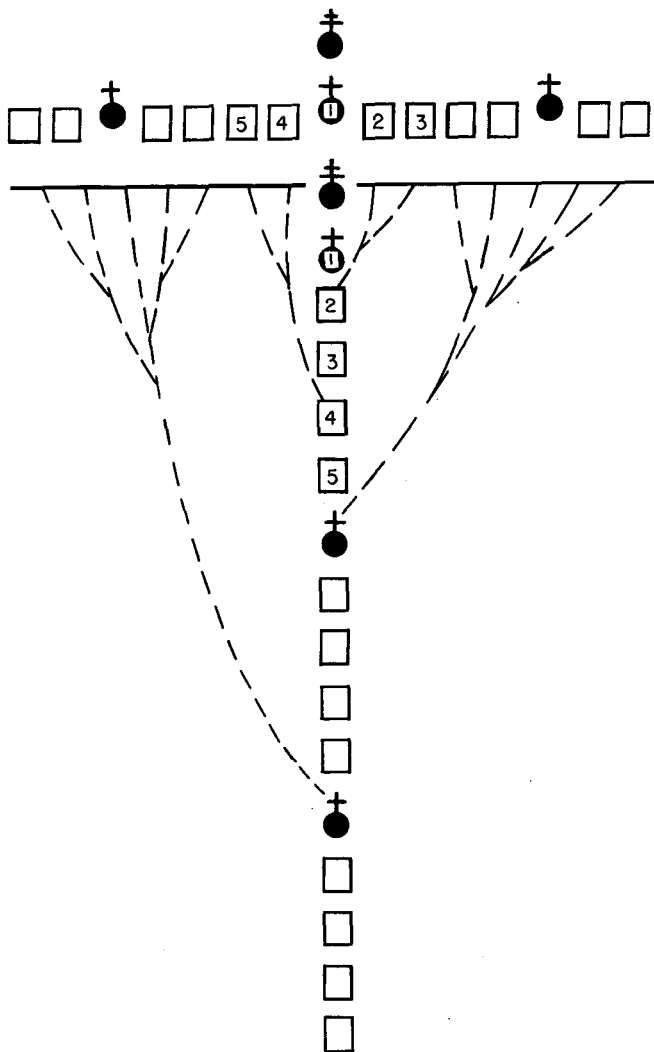
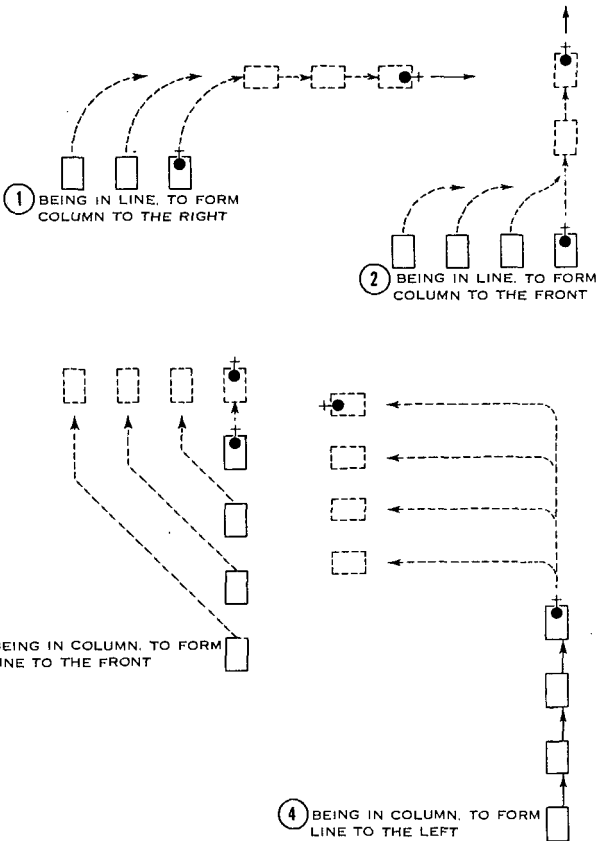
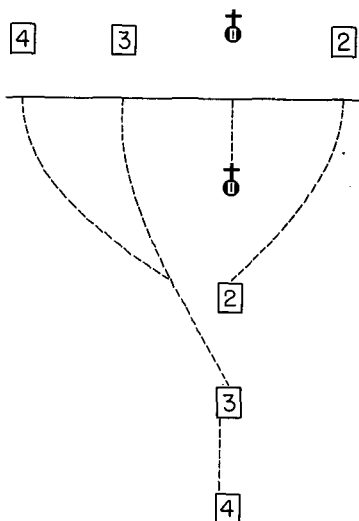

Figure 61. Forming line from column in armor unit.



*Figure 62. Moving vehicles changing direction of march in line or column.*

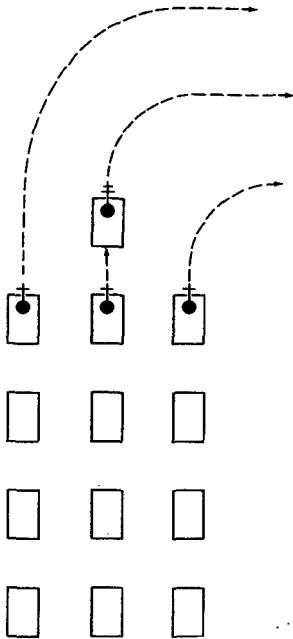



*Figure 63. Forming line from platoon in column with less than five vehicles.*

changing formation until they arrive near their new positions where they form a line, when required. When a line is formed in any direction other than the direction of march, the head of the column is turned in the new direction before the deployment is ordered.

- (3) Platoons of five vehicles form a line from column as shown in figure 61. Platoons of less than five vehicles form a line in the same manner as those for the platoon with five vehicles as shown in figure 63.
- (4) To change the direction of march for a unit, the commander directs the movement of the base on the arc of a circle so that the



*Figure 64. Moving vehicles changing direction of march in mass formation.*

pivot turns on a minimum radius. For movements to the flank, all vehicles turn simultaneously on a minimum radius in the direction indicated by the commander.

- (5) When the unit is in a column formation, the elements behind the base successively change direction in the same manner and on the same ground as the base (fig. 64).
- (6) When the unit is in any formation except column, the other elements regulate on the base and maintain their relative positions.

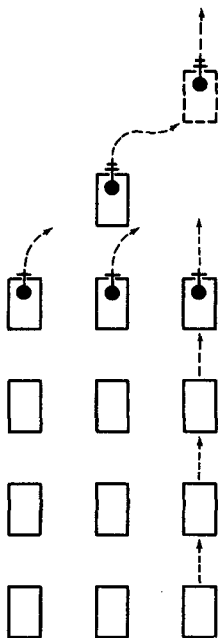

*Figure 65. Forming a single column from a formation of vehicles with several columns abreast.*

- (7) Changes in direction are made on a radius of not less than 15 yards.

### **168. To Form a Single Column From a Mass**

The commander signals or commands COLUMN and points to the column leader who is to lead off. He then moves his own vehicle in the desired direction, followed by the leading vehicle of the designated column. The leading vehicle is followed by the remaining vehicles of that column. The other columns follow in succession (fig. 65).

## Section III. SIGNALS

### 169. General

*a.* When conditions make oral commands inadequate, signals are used for transmitting commands and warnings. The signals described in this manual are the arm and hand signals used in mounted drill.

*b.* When a movement is to be executed by one unit or all units of a command, a preliminary signal designating the unit or units to execute the movement is given. The person giving the signal faces the unit or units for whom it is intended. The signal is given either from the ground or from a vehicle. The signal for executing the movement is given as soon as the preliminary signal has been understood.

*c.* One signal is preferable to a combination of signals. When a combination of signals is used, the signals should be easily recognizable and given in the order in which the command is worded. For example, to signal **ASSEMBLE IN COLUMN OF PLATOONS** give the signal for **ASSEMBLE**, **COLUMN**, and **PLATOONS** in that order.

*d.* To change the formation of lower units, it is preferable for the leader to move the base element and indicate or signal the desired formation. All other elements conform to the base.

### 170. Arm and Hand Signals

The general arm and hand signals used for mounted drill are—

*a.* **ATTENTION.** Extend your arm sideward slightly above the horizontal, palm to the front, and wave toward the head several times.

*b.* **FORWARD; TO THE REAR.** Face in the desired direction of movement and raise your hand vertically to the full extent of your arm, palm to the front; lower your arm and hand to the horizontal in the direction of the movement.

*c.* **BY THE RIGHT (LEFT) FLANK.** Face the unit being signaled, extend both arms horizontally in the direction of the desired movement.

*d.* **MOUNT.** Extend your arm downward at your side, palm out, and raise your arm sideward and upward to an angle of  $45^\circ$  above the horizontal. Both arms may be used when giving this signal.

*e.* **DISMOUNT.** Extend your arm sideward and upward to an angle of  $45^\circ$  above the horizontal, palm down, and lower it to your side. Both arms may be used when giving this signal.

*f.* **CLOSE FORMATION.** (From turrets of tanks and open vehicles.) From the position of arms extended sideward, palms up, bring the arms vertically overhead until the palms touch. Repeat as necessary.

*g.* **CLOSE FORMATION.** (From cabs of closed vehicles.) Extend your left arm sideward to the horizontal, palm up, and raise it as high as the cab permits. Repeat several times.

*h.* **MASS.** Extend your arm horizontally sideward, palm up, fingers extended and joined; then, by flexing your elbow, bring the tips of your fingers to the point of your shoulder several times.

*i.* **EXTEND.** Raise your arms vertically overhead, with your palms together. Then drop your arms sideward to the horizontal position, palms down. Repeat this several times. (In a formation

possessing width and depth, extension is made in both directions.)

*j.* **STOP ENGINES.** Draw your right hand, palm down, across your neck in a "throatcutting" motion from left to right.

*k.* **MOVE IN—GEAR OR SPEED.** Hold up the number of fingers which indicates the desired gear or speed.

*l.* **MOVE IN REVERSE.** Face the unit being signaled, extend your arm and hand at shoulder level, palm toward the driver, and make a pushing motion. Repeat this several times until the vehicle has moved to the desired position.

*m.* **START ENGINES.** Rotate your arms in front of your body, describing circles to simulate cranking.

*n.* **COLUMN.** Raise your arm vertically. Then drop your arm to the rear and describe circles in a vertical plane with your arm fully extended.

*o.* **LINE.** Raise both arms sideward to the horizontal.

#### **Section IV. MOUNTED REVIEWS**

##### **171. General**

*a.* The procedures described in paragraphs 105 through 107, 112 through 119, 121 and 132 are applicable to all units with vehicles, mounted or dismounted.

*b.* The national and unit colors are mounted on the vehicle when carried in mounted formations. The color bearers and the color guards ride in the vehicle with the colors. The vehicle carrying the colors takes its position at or near the center of the formation and in the interval between battalions or similar

elements. When the troops dismount from their vehicles and form into foot formations, the colors are removed from the vehicle and posted in the same relative position as for a dismounted formation.

*c.* In mounted formations the guidon is flown from the commander's vehicle.

*d.* Unless ordered otherwise, all vehicular weapons are mounted and carried with their covers removed. Machineguns, except for the anti-aircraft weapons, are adjusted and clamped with the barrels horizontal and aligned with the axis of the vehicle. Anti-aircraft machineguns are pointed to the left and upward at the maximum elevation. Rifles, carbines, and submachineguns are carried in the prescribed positions.

*e.* All tank hatches are open. The windshields of the vehicles are closed. The bows and canvas tops are down on all combat vehicles and vehicles carrying personnel. The bows and canvas tops are up on the cargo-carrying vehicles. The rear curtains are closed and fastened. The radio antennas are secured as prescribed.

## **172. Preparations**

The line on which the foot troops are to form is marked. The post of the reviewing officer and the line of march are marked with flags. The reviewing stand and markers are located so that as each unit passes in review its right flank is 20 yards from the reviewing officer. When formed for battalion reviews, the line of *troops* is 145 yards in front of the reviewing stand; however, in the case of larger reviews, the line of *unit commanders* is 145 yards in front of the reviewing stand (fig. 66). The band and buglers are formed dismounted and take their

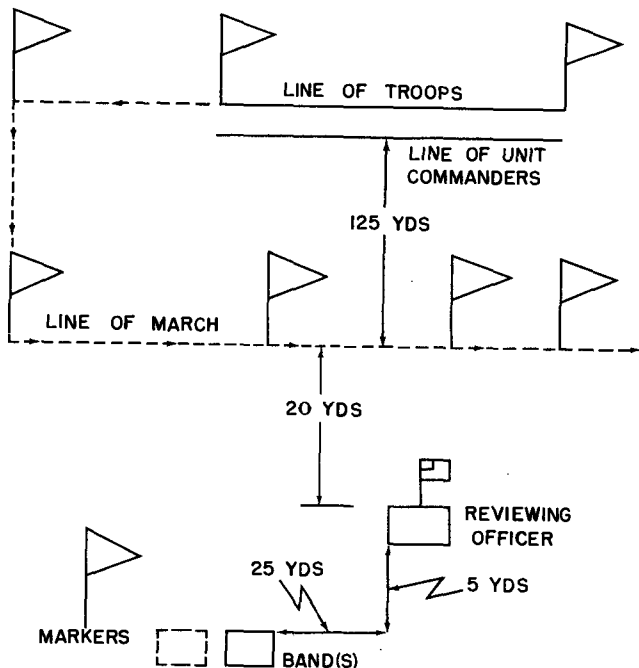

Figure 66. Preparation for mounted review.

post 25 yards to the left and 5 yards to the rear of the reviewing officer. Where more than one band is present, the additional band or bands form on the left of the first band. The bands may be massed. The bands play during the reviewing officer's inspection and during the march in review.

### 173. Formation

a. The normal formation of the battalion for ceremonies is a *line of masses*. However, a *column of masses* may also be used. For large reviews, a *line*.



*of battalions in line of masses* is preferable; but where space is the controlling factor, *a line of battalions in columns of masses* may be used.

*b.* In reviews for units larger than the battalion, the battalion commander's vehicle is 20 yards in front of the center of his unit. The commander's vehicle is centered 40 yards in front of the unit. Staff vehicles, except the second in command of a company, form with the right flank of their line 5 yards in rear of the commander's vehicle.

*c.* When platoon leaders and company and battalion commanders are dismounted, they take positions 6 steps directly in front of their respective vehicles.

*d.* Extra vehicles, administrative vehicles, and transportation which is not a part of a combat platoon or similar unit may be formed as an additional column on the left of each company or similar unit. It may be desirable to group the administrative and extra vehicles in columns at the left of each battalion or other unit. When platoons contain less than five vehicles, additional vehicles may be added as part of the platoon.

*e.* All units form and take their positions on the line of troops before the adjutant's call.

*f.* The reviewing officer is dismounted and generally receives the review from a reviewing stand.

#### **174. Inspection**

When the troops remain in the vehicles, eyes right is not executed as the reviewing party approaches.

#### **175. March in Review**

*a.* When the reviewing officer has resumed his post (fig. 67) after inspecting the troops, or when

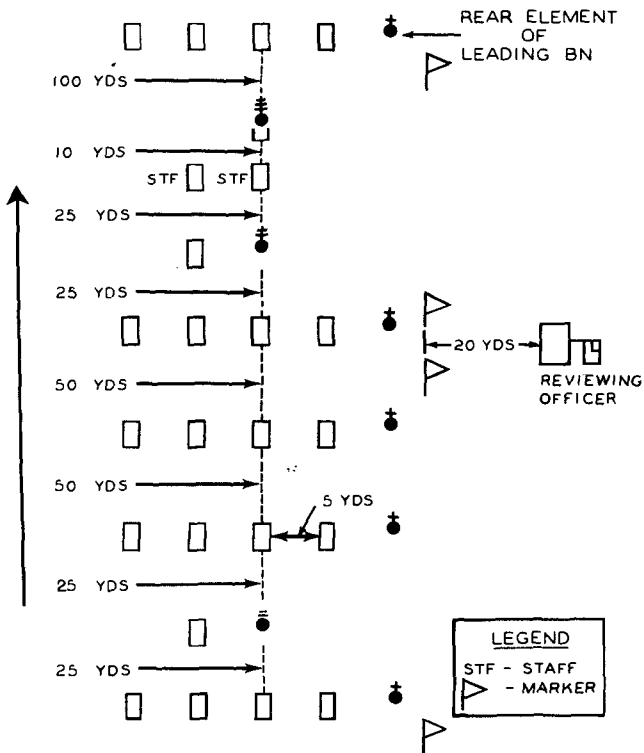

Figure 67. Passing in review (line formation mounted).

he indicates he does not desire to inspect the troops, the commander of troops commands: PREPARE TO PASS IN REVIEW, MOUNT.

b. At the command MOUNT, the troops break ranks, move at double time, and mount. The engines are started. When the troops remain in the vehicles, the command MOUNT is not given.

c. When the commander of the troops observes that the troops are mounted, he climbs into his ve-

hicle and commands, usually by radio: **PASS IN REVIEW.**

*d.* When the commander of the unit on the right flank receives the command to **PASS IN REVIEW**, he gives the commands to start the **MARCH**. Each successive commander of a mass formation on the line of troops, in turn, gives the command to follow the unit on his right flank.

*e.* Units may march in review with their elements in line, column, or mass. The sequence of commands for passing in review is as follows:

- (1) *Line.* By the right flank is executed successively by platoons at the command **PASS IN REVIEW**. Commands or signals of execution are given by each platoon leader. By the left flank is executed successively by platoons to make the next change of direction at the end of the review field. By the left flank is executed successively by platoons to make the last change of direction and bring them in line for passing the reviewing stand. Figure 67 shows the formation for passing a reviewing stand.
- (2) *Column.* Right turn is executed successively by companies in mass at the command **PASS IN REVIEW**. The commands or signals of execution are given by each company commander. Left turn is executed successively by companies in mass to make the last change of direction so that the company will be in mass for passing the reviewing stand.

*f.* Mass formation for passing in review is executed in the same manner as for a column, except when battalions are in line of masses or in line of companies with companies in column.

*g.* Commanders of platoons and all higher unit commanders salute as they pass the reviewing officer. They begin the salute 15 yards from the reviewing stand and hold it until they are 15 yards beyond it.

*h.* The review ends when the rear element of the command has passed the reviewing officer. When the review is ended, the unit commanders take charge of their unit (at a previously designated point) and move them as directed in the review instructions. When an inspection follows the review, the units move to the designated area.

## **176. Road Reviews**

Road reviews usually are conducted in column formation with as many vehicles abreast as the width of the road permits. Special instructions are issued for control of traffic, distances between vehicles, speeds, safety precautions, markers, and guides. To prevent traffic jams, divergent routes are designated for the units that have passed the reviewing stand.

## **Section V. INSPECTION OF MOUNTED UNITS**

### **177. General**

*a.* Inspections may be mounted or dismounted.

*b.* The administrative details for the inspection of various units are limited by the variety of armored and motorized elements and the available terrain. The area for the inspection is marked care-

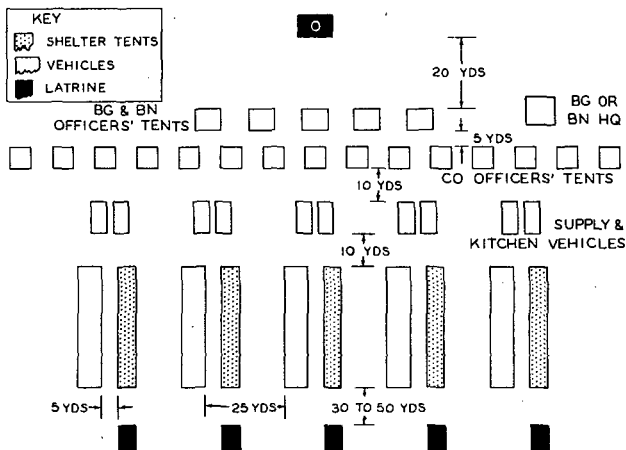

Figure 68. A typical formation for field inspection.

fully and lines are established to simplify the inspection. A field inspection of a large unit may require an advance detail from each battalion to assist in the layout of the area. Suggested arrangements for field inspections are shown in figures 68 and 69.

c. When all the elements are in position, the adjutant reports to the commanding officer who, after receiving the report, orders the troops to prepare for inspection.

d. When a band is present, it plays during the inspection.

e. When desired, an alternate formation may be used (fig. 69) with shelter tents pitched in lines separate from the lines of vehicles. The shelter tents may be pitched in double lines by company or similar unit, forming a company street. The ve-

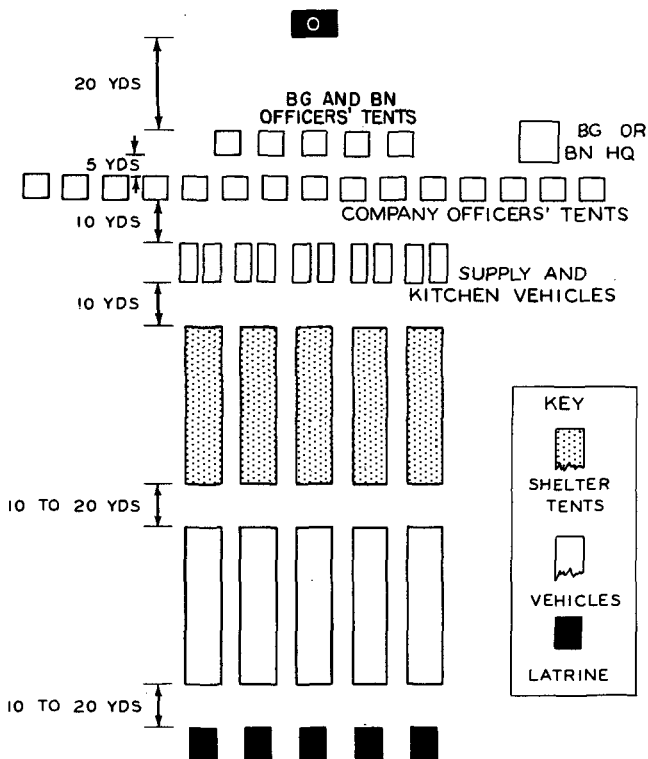
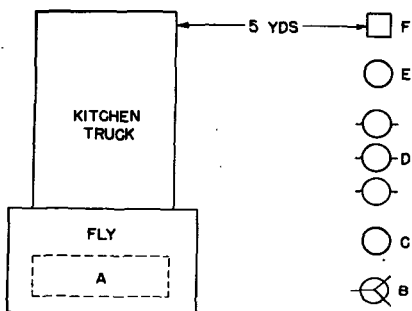

Figure 69. An alternate formation for field inspection.

hicles are in line in extension of the street of the corresponding company.

f. The company officers' tents are erected facing their respective company streets.

g. The colors are placed in front of the commanding officer's tent. The guidon is placed at the right front of each company commander's tent.



#### LEGEND

- A. SERVING TABLE
- B. LISTER BAG
- C. GARBAGE PIT
- D. HOT WATER
- E. GREASE PIT
- F. FUEL (IF REQUIRED)

Figure 70. A type layout for kitchen equipment.

### 178. Display of Equipment

a. Vehicles are displayed with hoods raised ; engine compartments, doors, and battery boxes open ; and tailgates down. The tools are displayed directly in front of each vehicle.

b. The mounted weapons are prepared for action. The towed weapons are uncoupled, moved 2 yards to the rear, and prepared for action.

c. Organizational equipment is displayed on the ground in the rear of the vehicle. The kitchens may be displayed as shown in figure 70. Additional equipment not shown in figure 70 is placed under the kitchen fly and in the kitchen truck.

d. Individual equipment, including weapons, is displayed in front of the shelter tents as prescribed in FM 21-15.

## APPENDIX I

### REFERENCES

---

















- AR 320-50 Authorized Abbreviations.  
AR 600-25 Salutes and Honors.  
AR 840-10 Flags.  
SR 320-5-1 Dictionary of United States Army Terms.  
SR 840-10-1 Description and Use of Flags, Guidons, Tabards, and Automobile Plates.  
FM 21-5 Military Training.  
FM 21-15 Individual Clothing and Equipment.  
FM 21-30 Military Symbols.  
FM 21-60 Visual Signals.  
FM 23-5 U. S. Rifle, Caliber .30, M1.  
FM 23-7 Carbine, Caliber .30, M1, M1A1, M2, and M3.  
FM 23-15 Browning Automatic Rifle, Caliber .30, M1918A2.  
FM 23-35 Pistols and Revolvers.  
FM 26-5 Interior Guard Duty.  
DA Pam 21-39 Conduct of a Military Funeral.  
DA Pam 108-1 Index of Army Motion Pictures, Film Strips, Slides, and Phonorecordings.  
DA Pam 310-3 Index of Training Publications.  
DA Pam 310-5 Index of Graphic Training Aids and Devices.



## APPENDIX II

### SYMBOLS

---

	BATTLE GROUP COMMANDER (COMMANDER OF TROOPS)
	BATTLE GROUP EXECUTIVE OFFICER (GROUP "A" COMMANDER AND STAFF)
	SENIOR STAFF MEMBER (GROUP "B" COMMANDER AND STAFF)
	COMPANY COMMANDER
	COMPANY COMMANDER ALTERNATE POSITION
	EXECUTIVE OFFICER (COMPANY)
	PLATOON LEADER
	FIRST SERGEANT
	PLATOON SERGEANT
	SQUAD LEADER
	FIRE TEAM LEADER
	MESSENGER
	SQUAD MEMBER
	DIRECTION TROOPS ARE FACING
	GUIDON
	COLORS

*Figure 71. Master Key to symbols in illustrations.*

## INDEX

	Para- graphs	Page
Adjust slings.....	46	63
Adjutant.....	111	157
Alining:		
Company.....	93	133
Mass formation.....	100	138
Platoon.....	82	115
Squad.....	67	95
Arm and hand signals for mounted drill..	169, 170	227
Attention, position.....	19	22
Aviation at funeral.....	140	204
Awards.....	117	168
Backward march.....	28	35
Band.....	111, 116, 134	157, 166, 195
Base:		
Definition.....	62	88
Mounted drill.....	154	212
Battalion in:		
Column.....	157	213
Line.....	157	213
Mass.....	157	213
Battle group:		
Field inspection.....	177	235
Formations.....	108, 110, 111	153, 154, 157
In line, companies in mass.....	110	154
Parade.....	120, 121	176, 177
Review, companies in mass.....	118	172
Staff.....	109	154
Movement.....	111	157
Position.....	117	168

	Para- graphs	Page
Bayonet, fix and unfix.....	47	65
Bugler.....	133	195
By the numbers.....	4, 5	5, 8
Cadence.....	4, 13, 18	5, 15, 21
Command.....	23	30
Rifle movements.....	36	40
Caisson (for funeral).....	134-136	195
Cannon salute.....	139	203
Caparisoned horse.....	134-136	195
Carry guidon.....	59	84
Ceremonial firing.....	145-148	206
Change:		
Direction:		
Company in column.....	96	135
Mass.....	101	138
Moving vehicles.....	167	220
Interval:		
Company.....	97	136
Platoon.....	84	117
Step.....	30	35
Chaplain (at funeral).....	133, 142	193, 204
Color:		
Battle group.....	125	186
Salutes.....	126	187
Decoration.....	117	168
Escorts.....	123	182
Guard.....	127	188
Movement.....	128	191
National.....	125	186
Salute.....	126	187
Positions.....	129-132	191
Column:		
Changing direction:		
Platoon.....	85	117
Squad.....	69	98
Definition.....	62	88

	Para- graphs	Page
Of twos:		
Company.....	98	136
From file.....	74	105
Platoon.....	87	120
To form from company mass.....	102	139
Commander of troops.....	108, 110, 111, 124	153, 154, 157, 183
Command(s):		
Execution.....	7, 12	11, 14
From ranks.....	16	20
Mass.....	15	18
Preparatory.....	7, 12	11, 14
Supplementary.....	8, 90	12, 128
Voice.....	6, 9-15	10, 13
Company:		
Commander (post).....	89	123
Drill.....	91-104	130
Halt.....	15	18
In column, platoons in column.....	89	123
In column, platoons in line.....	89	123
In line, platoons in line.....	89	123
In mass.....	89	123
Inspection.....	106	142
Mass from column.....	99	137
Count off (execution).....	71	100
Cover, definition.....	62	88
Decorations and awards.....	117	168
Definition:		
Drill terms.....	2, 18, 77	3, 21, 109
Guidon.....	56	79
Squad formations, terms.....	62	88
Depth, definition.....	62	88
Dismiss the:		
Company.....	92	132
Squad.....	65	93
Distances, mounted drill.....	155	213

	Para- graphs	Page
Double time:		
Definition.....	18	21
In place.....	33	37
March.....	32	36
Drill:		
And ceremonies, need for.....	3	4
Instruction:		
Conduct.....	4	5
Step-by-step method.....	4	5
Nomenclature (rifle).....	36	40
Element:		
Definition.....	18	21
Escorts:		
Funeral.....	134	195
Honor.....	123	182
Executive officer (post).....	89	123
Eyes right.....	22	30
Face in marching.....	31	36
Fall in.....	64	92
Field inspection, battle group.....	177	235
File, definition.....	62	88
Firing squad (at funeral).....	134, 136	195, 201
First sergeant (post).....	89	123
Fix bayonets.....	47	65
Flag:		
At funeral.....	134, 137	195, 202
Marking.....	112	161
Formation, definition.....	62	88
Form:		
A file (platoon).....	86	118
For shelter tents.....	88	121
The company.....	91	130
The platoon.....	81	114
Fraternal organization at funeral.....	141	204
Funeral:		
Chapel.....	133, 134	193, 195
Crematory.....	137	202
Director.....	134	195

	Para- graphs	Page
Funeral—Continued		
Floral tributes.....	144	205
Graveside.....	133, 136	193, 201
Procession.....	134	195
Guide.....	77, 78	109, 110
Position in company formation.....	89	123
Guidon bearer:		
Post in formations.....	4, 77, 89	5, 109, 123
Halt:		
Facings.....	21	27
Rests.....	20	24
Honor guard.....	124	183
Incline to the right.....	69	98
Inspecting officer.....	106, 107	142, 151
Inspection:		
Arms:		
Automatic rifle.....	49	68
Carbine.....	54	74
Pistol.....	51	68
Rifle.....	44	56
Battle group.....	107	151
Ceremonial.....	116	166
Company.....	106	142
Honor guard.....	124	183
Mounted units.....	177, 178	235, 238
Formation.....	177	235
Interval:		
Change.....	66	93
Close.....	64	92
Definition.....	62	88
Mounted drill.....	155	213
Normal.....	64	92
Key to symbols.....	2, app. II	3, 240
Kitchen layout for inspection.....	178	238
Left shoulder arms.....	42	54
Line, definition.....	62	88

	Para- graphs	Page
Manual of arms:		
Automatic rifle.....	48, 49	67, 68
Carbine.....	53-55	74
Guidon.....	56-60	79
Motorized troops (dismounted).....	152	212
Pistol.....	50-52	68
Rifle.....	35-48	39
March:		
In column from line.....	95	135
In place.....	26	33
In review.....	118	172
Mounted troops.....	175	232
To the flank.....	70	99
Motorized troops in ceremonies.....	149, 150	211
Base.....	154	212
Commander.....	153	212
Formations..... 157, 160, 167, 171, 173		213, 217, 220, 229, 231
Manual of arms.....	152	212
Massed vehicles.....	158	217
Movement of vehicles.....	163-168	219
Signals.....	169, 170	227
Weapons, disposition.....	151	211
Mounted reviews.....	171-176	229
Nomenclature (rifle), for drill.....	36	40
Noncommissioned officer:		
Post in formation.....	4, 77	5, 109
Oblique march.....	75	107
Officer:		
Post in formation.....	4, 77	5, 109
Open and close ranks:		
Company.....	94	134
Platoon.....	83	116
Oral examinations.....	5	8
Order arms.....	37, 43	42, 54
Order guidon.....	57	81

	Para- graphs	Page
Pallbearers.....	133, 134	193, 195
Parade:		
Battle group.....	120, 121	176, 177
Rest.....	38	43
Street.....	122	181
Passing in review.....	175	232
Patriotic organizations at funeral.....	141	204
Platoon:		
Drill.....	79, 81-88	112, 114
Formations.....	77, 80	109, 113
Leader (post in company formations).....	89	123
Sergeant.....	81	114
Post in company formations.....	89	123
Post arms.....	13, 40, 42	15, 46, 54
Posts in formations:		
Company commander.....	89	123
Executive officer.....	89	123
First sergeant.....	89	123
Guide.....	89	123
Guidon bearer.....	89	123
Platoon leader.....	89	123
Platoon sergeant.....	89	123
Present:		
Arms.....	43	54
Guidon.....	60	84
Presentation and honors.....	115	164
Quick time:		
Definition.....	18	21
Marching.....	24, 26	32, 33
Raise guidon.....	58	81
Rank, definition.....	62	88
Rear march.....	13, 29	15, 35
Rest:		
At halts.....	20	24
Movements.....	34	37
Positions with rifle.....	38	43
Retreat.....	119	175



	Para- graphs	Page
Review:		
Ceremonies.....	112	161
Definition.....	112	161
Mounted, preparations.....	172	230
Passing.....	175	232
Preparation.....	111	157
Road.....	176	235
Reviewing:		
Officer.....	114-118	163
Party.....	114, 116	163, 166
Rifle salute.....	45	58
Right face.....	13	15
Right flank, march.....	15	18
Right shoulder arms.....	41	48
Road review.....	176	235
Salute:		
Cannon.....	139	203
Color.....	115, 126	164, 187
Hand.....	22	30
National color.....	125	186
Rifle.....	45	58
Signals, motorized troops.....	169, 170	227
Sling arms.....	46, 53	63, 74
Slings, adjust.....	46	63
Squad:		
Attention.....	13	15
Drill.....	64-75	92
Formations.....	62	88
Stack arms.....	72	100
Standard:		
Battle group.....	125	186
National.....	125	186
Step(s):		
And marchings.....	23	30
Definition.....	18	21
12-inch.....	27	34
15-inch (half-step).....	25, 28	33, 35
30-inch.....	24	32
To change.....	30	35

	Para- graphs	Page
Supplementary commands.....	90	128
Take arms.....	73	103
Taps (at funeral).....	134, 137, 138	195, 202, 203
Trail arms.....	39	46
Unfix bayonets.....	47	65
Unslung arms.....	46	63
Vehicles:		
Formation.....	160, 162	217, 218
Mass.....	155, 157	213
Intervals.....	155	213
Movement.....	163-168	219
Voice:		
Control.....	10	13
Distinctness.....	10	13
Inflection.....	12	14

[AG 353 (17 June 53)]

By Order of *Wilber M. Brucker*, Secretary of  
the Army:

MAXWELL D. TAYLOR,  
*General, United States Army,*  
*Chief of Staff.*

Official:

HERBERT M. JONES,  
*Major General, United States Army,*  
*The Adjutant General.*

**Distribution :**

*Active Army:*

CNGB (1)	USAWC (5)
Technical Stf, DA (1)	USACGSC (15)
Technical Stf Bd (2)	Br Svc Sch (5) except
USCONARC (15)	USAARMS (850)
US ARADCOM (2)	USACMLSCH (62)
Rgn HQ US ARADCOM	USAES (12)
(2)	AMSS (550)
OS Maj Comd (5)	USA Ord Sch (700)
OS Base Comd (5)	USA Qm Sch (650)
Log Comd (3)	USASCS (10)
MDW (2)	USATSCH (200)
Armies (5)	USAIS (981)
Corps (5)	PMST (5)
Div (5) (Ea CC) (5)	ROTC and NDCC Units
Brig (3)	(1 ea student)
Regt/Gp/bg (5)	USATC (25)
Bn (5)	Mil Dist (3)
Co/Btry (3)	USA Corps (Res) (3)
Ft & Camps (2)	Sectors, USA Corps
USMA (1,045)	(Res) (3)

*NG:* State AG (6) ; units—same as Active Army.

*USAR:* Same as Active Army.

For explanation of abbreviations used, see AR 320-50.