

## DEPARTMENT OF THE ARMY FIELD MANUAL

---

S/S BY SAME  
DTD 19 MAY 78

# AIRDROP OF SUPPLIES AND EQUIPMENT IN THE THEATER OF OPERATIONS

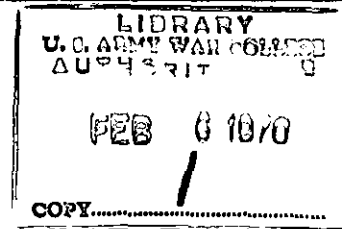

HEADQUARTERS, DEPARTMENT OF THE ARMY  
DECEMBER 1969

**AIRDROP OF SUPPLIES AND EQUIPMENT IN THE THEATER OF OPERATIONS**

	Paragraph	Page
CHAPTER 1. INTRODUCTION		
Section I. General .....	1-1-1-3	1-1
II. Airdrop System .....	1-4-1-7	1-2
CHAPTER 2. AIR SUPPLY ACTIVITIES		
Section I. General .....	2-1-2-4	2-1
II. Army Air Supply Support .....	2-5, 2-6	2-2
III. Airdrop .....	2-7, 2-8	2-4
CHAPTER 3. AIRDROP SUPPLY COMPANY		
Section I. General .....	3-1-3-5	3-1
II. Company Activities .....	3-6-3-8	3-2
III. Operations .....	3-9-3-12	3-4
CHAPTER 4. AIRDROP EQUIPMENT REPAIR AND SUPPLY COMPANY		
Section I. General .....	4-1-4-3	4-1
II. Company Activities .....	4-4-4-6	4-1
III. Maintenance Operations .....	4-7-4-9	4-5
IV. Supply and Storage Operations .....	4-10, 4-11	4-6
APPENDIX A. REFERENCES .....		A-1
B. DUTIES OF COMPANY PERSONNEL .....		B-1
C. CLASSES OF SUPPLY .....		C-1
D. EMPLOYMENT OF NONAIR DEFENSE WEAPONS AGAINST AIRCRAFT .....		D-1
INDEX .....		Index-1

*HC* ✓ *HC* ✓  
\*This manual supersedes FM 10-8, 22 October 1964 and FM 10-8-1 (Test), 18 April 1967.

## CHAPTER 1

### INTRODUCTION

#### Section I. GENERAL

##### 1-1 Purpose and Scope

*a.* This manual provides guidance for U.S. Army units concerned with the airdrop of supplies and equipment in a theater of operations. It presents direction and guidance which may be applied to specific situations and conditions of employment. The information presented is applicable, unless otherwise specified, to—

(1) General war, including considerations of operations in nuclear, chemical, biological, and radiological environments.

(2) Limited war.

(3) Cold war, inclusive of stability operations.

*b.* This manual contains general background information on the airdrop of supplies and equipment. It also covers basic Army, Air Force, and coordinative responsibilities for air supply activities in a theater of operations. In addition, the manual discusses the organization and operations of Army units primarily concerned with airdrop support operations.

##### 1-2. Comments

Changes in policy and refinements in organizational structure will necessitate changes or revisions. Field experience may suggest refinements or improvements. Users of this manual are encouraged to submit recommendations to improve its clarity or accuracy. Comments should be keyed to the page, paragraph, and line of the text in which the change is recommended. Reasons should be provided for each comment to insure understanding and complete evaluation. Recommended changes or comments to improve this manual should be prepared using DA Form 2028 (Recommended Changes to Publications) and forwarded direct to the Commandy Officer, United States Army Combat Developments Command Supply Agency, Fort Lee, Virginia, 23801. Originators of proposed changes which would constitute a significant modification of approved Army doctrine may send an information copy, through command channels, to the Commanding General, U.S.

Army Combat Developments Command, Fort Belvoir, Virginia 22060, to facilitate review and followup.

##### 1-3. Orientation to Terms

Air movement is a general term covering all transport of units, personnel, supplies, and equipment by air. It includes air landing and airdrop and covers both operational and administrative movements.

*a. Airborne Operations.* Airborne operations cover the movement and delivery by air into an objective area of combat forces and their logistic support for the execution of a tactical or a strategic mission. The means employed may be any combination of airborne and air transportable units and types of transport aircraft, depending on the mission and overall situation.

*b. Airmobile Operations.* Airmobile operations are those in which combat forces and their equipment move about the battlefield in organic air vehicles under the control of a ground force commander to engage in ground combat. While there are many similarities between joint airborne and airmobile operations, so far as organization and planning are concerned, there are differences in execution.

*c. Air Landing.* Air landing is the method of delivery by which personnel and equipment are moved by air and disembarked or unloaded after the aircraft has landed. It is a preferred method since cargo is delivered with the least chance of loss or breakage and requires a minimum of handling both in preparation for delivery and recovery. It is also desirable because it makes the most efficient use of available cargo space. Air landing may present a requirement for construction of air landing facilities or rehabilitation of existing ones. Air landing includes helicopter delivery of sling loads which does not necessarily require a prepared landing facility.

*d. Airdrop.* Airdrop is the unloading of personnel and materiel from aircraft in flight.

*e. Airdrop Equipment.* The term airdrop equip-

ment is applied to materials, devices, hardware, and other items used to prepare loads for airdrop.

*f. Airdrop Rigging.* Rigging is a general term used to describe the processes and procedures by

which a specific item or load of supplies is prepared for airdrop. It includes the assembly, loading, and marking of airdrop containers, platforms and platform assemblies, and the attachment of parachutes to prepared loads.

## Section II. AIRDROP SYSTEM

### 1-4. General Summary

*a.* The airdrop support system described in this manual is applicable to a force of any size or composition operating within the general framework of organization identified in FM 54-3, FM 54-4, FM 54-7, and FM 100-10. Such framework provides for a theater army support command (TASCOM), a field army support command (FASCOM) in each field army, a supply and maintenance command (SMC) with responsibility for general support supply and maintenance in the communications zone, and support brigades as the major subordinate commands of the FASCOM for the provision of supply and maintenance in the combat zone. A stock control center (SCC), or comparable activity, is located at each support brigade headquarters. Inventory control centers (ICC) or comparable activities are control activities located at the FASCOM and at the SMC. The center, at each level, is serviced and supported by automatic data processing equipment (computer systems), and functions as the centralized supply management agency of the command. (For simplicity in this manual, these activities are referred to by the SCC or ICC designation).

*b.* In application, airdrop is an alternate means for supply of units in a theater of operations. It serves as the primary means in support of conventional forces beyond enemy lines and of specialized operations. It provides a means of resupply when ground lines of communication are disrupted and air landed operations are infeasible or impractical. Airdrop has a primary role in support of airborne operations and as a means for supply of tactical units in combat.

### 1-5. Airdrop System Description

Requests for airdrop are placed on the lowest headquarters capable of satisfying the requirement. In the combat zone, this is the FASCOM which normally is charged with the control of airlift allocated to it and the unit that stocks, prepares, and rigs supplies for airdrop. Requests which must or can be more effectively filled from the COMMZ are placed on the TASCOM for action.

*a. Field Army Airdrop System.* Normally the field army commander has units assigned which provide an organic capability to support daily airdrop of supplies and equipment. This capability (exclusive of airborne division airdrop capability) is provided by the assignment or attachment of air delivery companies to the field army as required. Air delivery units are usually assigned to the Army Support Brigade within the FASCOM.

(1) Request procedures are simple, direct, and confined to essential elements in command and supply channels (fig. 1-1). Airdrop requests (fig. 1-2) should contain such information as supply items required, identity of requesting unit, date and time airdrop is desired, and grid coordinates of the drop zone (DZ). When possible, requests should also include prominent land marks in the vicinity of the DZ, recommended direction of approach, DZ signal identifiers (panel or smoke), and known enemy air defense threats in the area of the DZ.

(2) Requests for airdrop supplies flow directly to FASCOM by the most expeditious means consistent with security. Requests are transmitted through logistic channels, directly from division to the FASCOM ICC. Corps and field army headquarters monitor and may amend, adjust or disapprove requests. As requests are received, the FASCOM ICC immediately coordinates with movements control. The ICC and MCC jointly direct the actions of the supply and transportation activities. To provide adequate responsiveness to requirements, the air delivery company stocks appropriate quantities of classes I, III, V, and other supplies as determined by the FASCOM ICC. The FASCOM ICC maintains inventory data on stocks located at the air delivery supply unit.

(a) Concerning class V items, inventory data are maintained by the FASCOM ICC for each corps slice. A separate, small account will be maintained for the class V stocks located at the airdrop supply company. The FASCOM ICC determines which unit will lose the class V stocks required by the airdrop supply company.

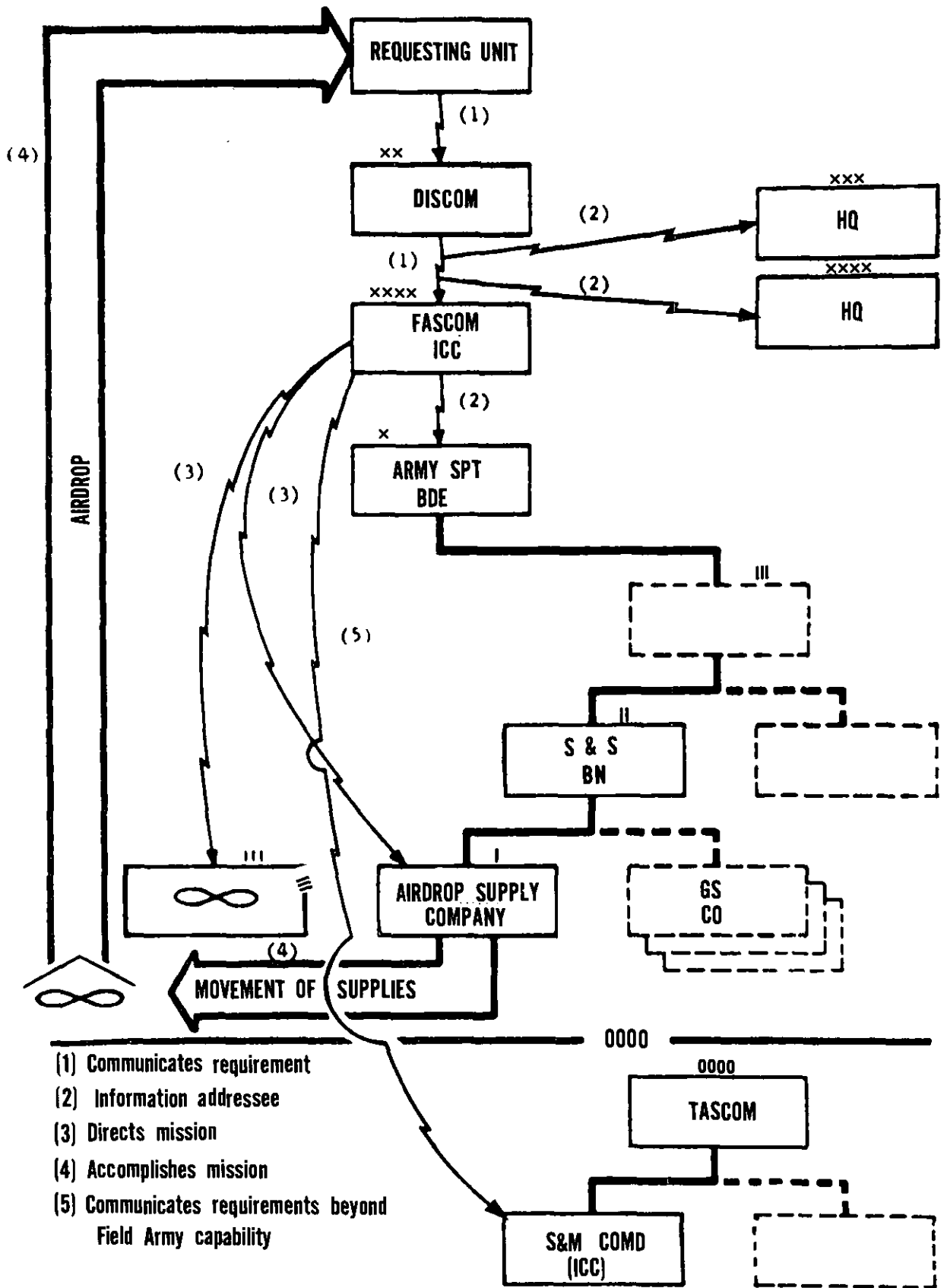

Figure 1-1. Airdrop request, FASCOM.

CLASSIFICATION

LINE NO.	REQUEST DATA (This line not transmitted)			
	1 UNIT CALLED	2 UNIT CALLING	3 REQUEST NUMBER	4 REQUESTER PRIORITY
5	CARGO DESCRIPTION AND LOCATION			
6	DESTINATION, DATE/TIME REQUIRED AT DESTINATION, AND RECEIVING ORGANIZATION			
7	DATE/TIME AVAILABLE FOR AIR LIFT			
8	RECOMMENDED NUMBER, TYPE OF AIRCRAFT, AND DELIVERY SYSTEM			
9	LOCATION OF LZ OR DZ AND METHOD OF MARKING			
10	FINAL CONTROL PROCEDURE			
11	INFLIGHT REPORTING PROCEDURE			
12	REMARKS, SPECIAL INSTRUCTIONS OR SPECIAL EQUIPMENT REQUIRED			
13	DATE/TIME SENT AND RECEIPT ACKNOWLEDGED			
14	ARTILLERY, AIR DEFENSE AND NAVAL GUNFIRE COORDINATION			
15	RESTRICTIVE FIRE PLAN INSTRUCTIONS			
16	APPROVAL AND MISSION NUMBER OR DISAPPROVAL			
17	DATE/TIME REQUESTER NOTIFIED			
	CLASSIFICATION			

Figure 1-2. Airdrop request form (suggested).

Corps allocations of class V items are not affected by this method of control.

(b) If supplies requested are not on hand at the airdrop supply company, the FASCOM ICC alerts the appropriate supply activity to deliver the items required to the airdrop supply company. As these shipments are directed, coordination is made with movement control. As airlift is arranged, materiel release orders are transmitted to the air delivery unit. The airdrop supply company prepares the supplies according to mode of delivery employed, and, in coordination with movement control, insures delivery to the designated point at the air terminal. In most cases, this will be the cargo aircraft door. The FASCOM ICC takes action to insure that stocks delivered are replaced.

(3) Requests which exceed the capability of FASCOM or which can be more effectively filled from COMMZ are forwarded to the TASCOCOM for action.

*b. COMMZ Airdrop System.* The TASCOCOM normally has an airdrop capability. This capability is designed to satisfy airdrop requirements that exceed field army capabilities, requirements generated by forces engaged in unconventional warfare, requirements for airborne operations, and exigencies that arise when nuclear weapons, enemy action, or guerrilla activity impact adversely on other modes of delivery. Airdrop supply companies in the COMMZ normally are attached to supply and service battalions of field depots. These companies operate at air terminals, field depots or intermediate rigging sites, depending upon which location is most feasible.

(1) Airdrop request procedures generally follow those used in the field army (fig. 1-3). In order to be highly responsive to these requests the airdrop supply company stores both rigged and unrigged supplies as described in the field army airdrop system. The Supply and Maintenance Command ICC specifies the quantity and type of supplies to be stored based on experience factors, contingency plans, etc.

(2) Airdrop requirements which exceed the capability of the field army and requests received from other sources are transmitted to the TASCOCOM ICC. The ICC determines the availability and location of the required supplies, coordinates the airlift and ground transportation requirements with the MCC and issues materiel release orders to the appropriate field depot. The field depot directs the airdrop supply company to execute the mission. The ICC and MCC must jointly

coordinate actions of the supply and airlift units. In addition, detailed coordination is necessary between the airdrop unit and the airlift unit. The airdrop supply company rigs the supplies according to the method of delivery to be utilized and insures that they are delivered to the required point at the designated air terminal. In most cases, this will be the cargo door of the aircraft. The ICC initiates action to replace airdropped items if required.

*c. Replenishment of Airdrop Equipment.* Responsibility for airdrop equipment is assigned to specified depots within the theater. Airdrop units submit requirements for airdrop equipment to the ICC which directs shipment of the required items from the appropriate field depot.

*d. Recovery Procedures for Airdrop Equipment.* The unit receiving the airdrop is responsible for the recovery and evacuation of airdrop equipment. Personnel from the airdrop supply company may, however, paradrop with the supplies and equipment to provide technical assistance to the receiving unit. Airdrop equipment (especially parachutes) is provided protection from adverse weather elements where possible. The recovered airdrop equipment is evacuated by the most expeditious means available to designated field depots in order that items may be inspected and/or repaired and returned to stock.

## 1-6. System Units

There are three Army units primarily concerned with and involved in airdrop support operations. They are the—

*a. Airdrop Supply Company.* This company can be employed in either the communications zone or in the field army to rig supplies for airdrop. It supports the field army in both planned and emergency airdrop requirements. It is also the principal source of resupply for the airborne division after the assault phase of a joint airborne operations. The company is treated in detail in chapter 3.

*b. Airdrop Equipment Repair and Supply Company.* This company operates from a field depot in the communications zone to support the Airdrop Supply Company or an airborne force equivalent to one airborne division. It stores, issues, and provides direct and general support maintenance for airdrop equipment. The company is treated in detail in chapter 4.

*c. Airborne Division Air Equipment Support Company.* This company is an organic unit of the airborne division. It performs for its division services similar to those that the Airdrop Equip-

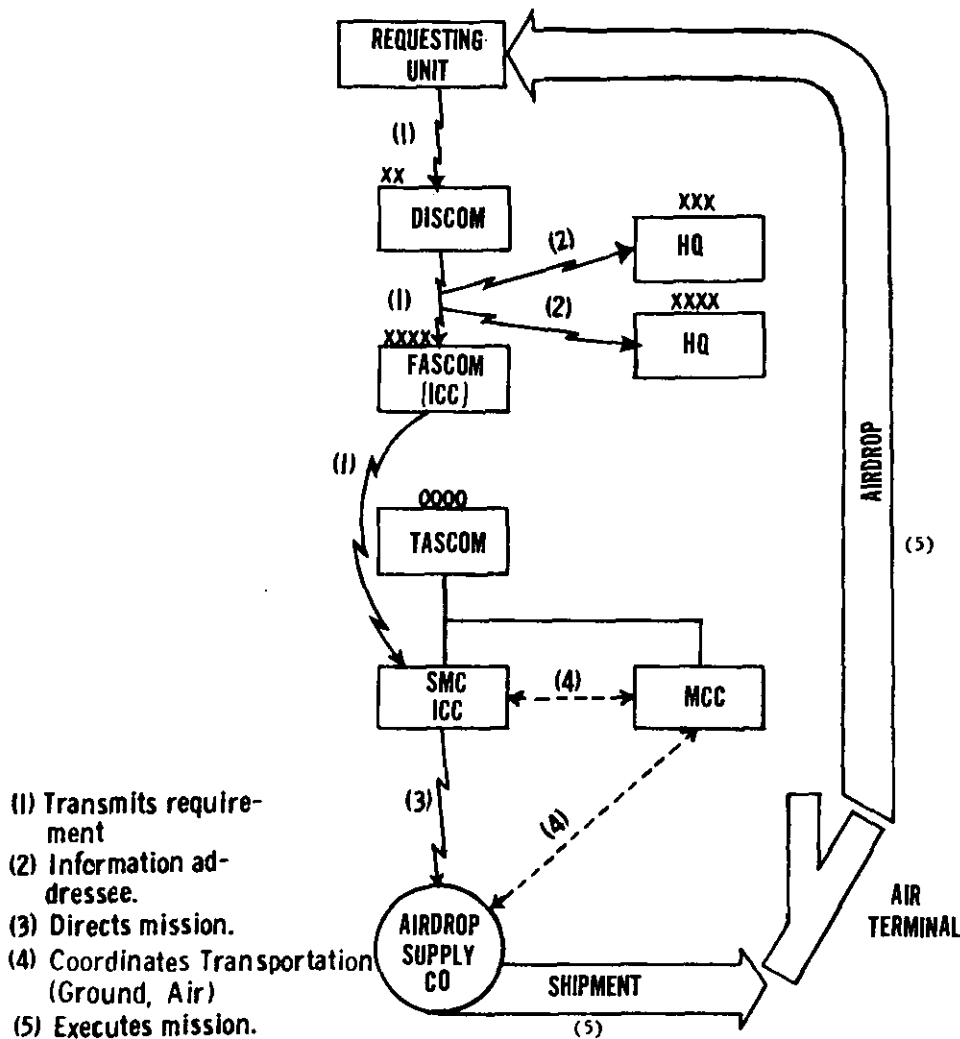

Figure 1-8. Airdrop request procedures.

ment Repair and Supply Company affords to the field army. The company is treated in detail in FM 29-50.

*d. Airmobile Division Aerial Equipment Support Company.* The aerial equipment support company is an element of the airmobile division when authorized an airborne brigade. The company supports the division by providing for the requisition, inspection, storage, packing, maintenance, and issue of equipment required for airdrop of personnel, supplies, and equipment. It also provides for the inspection of, and technical assistance in, packing, rigging, and loading of supplies and equipment. The company is treated in detail in FM 29-50.

*e. Air Equipment Support Platoon (Separate Airborne Brigade).* The air equipment support platoon is an element of the supply and service company, support battalion, separate airborne

brigade. It provides both the personnel and equipment to carry out all air equipment support missions of the battalion. The unit is treated in detail in FM 29-50.

### 1-7. Airdrop Equipment

Airdrop equipment is supplied and maintained by specialized units organized and equipped for airdrop missions. These units are also provided with various items of general purpose equipment.

*a.* Airdrop equipment can be divided into three major classifications:

(1) Rigging items include airdrop containers, platform and platform assemblies, cushioning materials, and other supplies and equipment used to prepare loads for airdrop. Detailed descriptions on the use and employment of these items are contained in technical manuals and technical bulletins of the 10-500-series.



(2) There are two general categories of parachutes, personnel and cargo. Detailed descriptions of these parachutes, their use and maintenance, may be found in technical publications of the TM 10-500- and TM 10-1670-series. An additional reference for the standard personnel parachute is found in TM 57-220.

(3) Maintenance items include parachute packing and inspection tables, parachute line separators, parachute packing weights, and fans.

*b.* In addition to airdrop equipment, units involved in airdrop operations are provided with such general-purpose equipment as medium-heavy duty sewing machines, general industrial sewing machines, and zig-zag machines. For handling supplies, they are equipped with forklift trucks, warehouse tractors, and trailers. Unit vehicles range from 1/4-ton trucks to 5-ton general cargo trucks.

## CHAPTER 2

### AIRDROP SUPPLY ACTIVITIES

---

#### Section I. GENERAL

##### 2-1. Basic Responsibilities

*a.* The basic responsibilities of the Army and Air Force and oversea Air Force air terminals are covered in AR 59-106. Joint Army and Air Force doctrine, responsibilities, and procedures for use in coordinating and executing tactical airlift operations are covered in FM 100-27. A brief discussion of these responsibilities when such inter- and intra-theater aircraft are involved appears in subsequent paragraphs of this section.

*b.* The utilization of Army air transport employed in combat service support operations, to include an Air Line of Communications (ALOC) is discussed in FM 55-46 and FM 55-46-1 (Test). It is treated also in paragraphs 2-5 and 2-6.

*c.* Joint Army and Air Force doctrine, responsibilities, and techniques employed by Army and Air Force components for planning and executing joint airborne operations are contained in FM 57-1. A brief discussion of the supply support aspects of such operations is presented in paragraph 2-7.

##### 2-2. Army Responsibilities

*a.* In an oversea theater of operations, the theater commander may establish a Joint Military Transportation Board (JMTB) to discharge his responsibilities in the disposition of transportation resources allocated by the Joint Chiefs of Staff, and to perform such other functions as may be directed. A discussion of the JMTB is contained in FM 55-10 and FM 55-6.

*b.* The theater army transportation officer, under the general staff supervision of the theater army G4, recommends the utilization of air transportation within the theater army. Allocations of available airlift are made to major subordinate commands by the theater army commander on a priority basis and in accordance with requests previously submitted to him. Allocations of air transportation to the field armies are made through army groups, if present, be-

cause of the influence of airlift upon tactical operations.

*c.* The Assistant Chief of Staff, Movements, at theater army support command (TASCOM) headquarters is responsible for movement planning and coordination of airlift allocated to TASCOM. This is used for cargo movement both within the communications zone and to the field armies. Theater army may direct that a portion of the airlift allocated to the TASCOM be used to support each field army. When this is done, the field army commander may establish priorities for airlift within the TASCOM support mission. Requirements for airlift within the communications zone and requirements for airlift in support of the field armies are consolidated by the Assistant Chief of Staff, Movements, TASCOM.

*d.* The field army commander normally assigns to the commander of the Field Army Support Command (FASCOM) responsibility for determining requirements for, and coordinating and administering the use of, administrative airlift allocated to the field army. Allocations of airlift to the field army normally are expressed in terms of tonnage for air delivery, daily number of sorties to be flown, or a combination of the two. Within this allocation, for sustained operations, the FASCOM commander specifies the type of material to be delivered, the times for delivery, and destinations. In addition, an allocation for on-call tonnages will be maintained. Allocations of available airlift are made to subordinate elements of the field army based on requirements of these elements previously submitted to field army.

##### 2-3. Air Force Responsibilities

*a.* Air Force airlift units assigned to the theater of operations are commanded by the theater commander through the theater Air Force commander. Maximum use of aircraft is obtained by central control and scheduled flights to which the bulk of the intratheater airlift is allocated. The

responsibilities of the airlift force commander include—

- (1) Scheduling of flights.
  - (2) Control of Air Force transportation operations.
  - (3) Operation of Air Force terminals.
  - (4) Coordination with the using service.
  - (5) Timely and accurate delivery.
- b. The designated airlift commander controls operations through the Airlift Control Center (ALCC). This center schedules flights and monitors operations, including special missions. The ATMC receives requests for airlift, processes them, and schedules the aircraft. It also consolidates requirements for forward movement of cargo with rearward air evacuation, notifies air terminals concerned, and directs and monitors the flight throughout the mission. The responsibilities of the Air Force and using services for the operation of terminals are contained in AR 59-106.

#### 2-4. Coordinative Responsibilities

a. Theater army establishes coordination with the airlift forces through an Airlift Liaison Co-

ordinating Officer (ALCO) stationed at the ATMC. This officer represents the Assistant Chief of Staff, Movements, TASCOM at air terminals in the communications zone. The FASCOM commander designates ALCO representatives at air terminals in the field army area. The ALCO—

- (1) Coordinates the movement of Army personnel, supplies, and equipment to and from the air terminal.
- (2) Maintains liaison with depots and other installations to insure that cargo arrives at the terminal on schedule.

b. Limited communications facilities are organic to units involved in airdrop operations. Organic communications capabilities of the airdrop equipment repair and supply company are supplemented by the area signal center responsible for providing signal support to units within the geographical area in which these units operate. Organic communications capabilities of the airborne division air equipment support company are supplemented by division signal battalion.

## Section II. ARMY AIR SUPPLY SUPPORT

#### 2-5. Air LOC Operations

a. It is necessary that the Army's combat service support system be organized and employed to keep pace with the mobility requirements of the combat forces. Under certain conditions, this will require Army air transport to operate over Army air lines of communication (air LOC's). Air LOC's connect an operating military force with a base of operations.

(1) Air movement of cargo and personnel throughout a theater of operations by Air Force intratheater airlift will be exploited to the maximum consistent with the tactical situation, availability of suitable landing areas, and the ability of recipients to receive the quantity of cargo delivered. Army operated Air LOC's will be established as an integral part of the Army's combat service support to the combat forces.

(2) Detailed information on the operation of an Air LOC is contained in FM 55-46 and FM 55-46-1. These manuals, together with the doctrine set forth in FM 100-27, provides—

(a) The basis upon which to organize and employ combat service support and tactical airlift forces within a theater of operations.

(b) For the interface between U.S. Air Force air transportation and U.S. Army trans-

portation to the final destination so that the tactical airlift system and the army logistics system are geared to each other from the logistics to the consumer.

b. The FASCOM commander controls the nature and extent of FASCOM Army air transport operations by assigning missions and establishing support priorities. Additionally, he controls through the FASCOM movement program the allocation and use of the air transport capabilities assigned to provide the army-wide air LOC service. In exercising this centralized control, he establishes policies to insure the necessary exercise of authority by transport unit commanders in carrying out their responsibility for effective execution of requirements.

(1) In operating a sustained air LOC, reliable and timely service is combined with maximum utilization of aircraft by centralized control of commitments and scheduled flight operations. The airlift commander establishes policies for air LOC flight operations and assigns operational missions to his subordinate commanders. In turn, these commanders furnish current availability and operational data, based upon which the airlift commander prepares the periodic airlift capability forecast used in developing the FASCOM

movement program. This capability commitment is forwarded to the FASCOM movements control center in accordance with established procedures.

(2) When mission-basis airlift is required and directed by FASCOM, the airlift commander coordinates and directs the commitment of necessary aircraft and aircraft support elements in a direct support role. Aircraft normally operate under control of the supporting force commander and upon completion of the mission, the airlift elements return to their parent units.

(3) Scheduled air LOC operations require timing and precision in loading and unloading aircraft. Both the cargo and aircraft are critical items. The action of shippers, terminal transfer personnel, and aircraft operators must be closely coordinated to insure timely movement of cargo and personnel as well as to facilitate efficient use of aircraft.

c. An air terminal is more than an airfield. It consists of transfer points, intransit or temporary storage areas; traffic control facilities; and, as necessary, aircraft maintenance installations. Air terminals in the army service area should be located at or near Air Force terminals and/or supply installations. Air terminals in the corps areas may be located at or near support brigade installations. Elements of the airdrop supply company may be included among the combat service support units employed at the terminal.

(1) Army-Air Force responsibilities at air terminals are delineated in AR 59-106. Responsibilities of Army aviation units, transportation terminal transfer units, and airdrop elements at air terminals follow a similar pattern.

(2) The aircraft commander is responsible for seeing that loads are not in excess of lift capacity; are properly placed, lashed, and secured; and that the aircraft is safe for flight.

## 2-6. Airborne Operations

In an airborne operation, the conduct of airdrop or resupply operations is influenced and determined by factors and considerations inherent in the tactical mission. Because an airborne operation is usually a joint enterprise, all participating forces must be completely integrated and authoritatively directed. Extensive and detailed planning and continuous coordination are essential to insure availability of required forces, control and direction of the combined ground-airborne effort, and provision of the necessary combat service support. The characteristics and execution of airborne division logistic operations are discussed in detail in FM 29-50 and FM 57-1.

### a. Mounting.

(1) The theater army support command supports an airborne operation mounted in or supported from the communications zone.

(2) Marshaling is the part of the mounting operation during which units move to temporary camps,\* if necessary, where final preparations for combat are completed; move to loading areas of departure airfields; and load for takeoff which concludes the mounting process. Two important requirements to successful mounting are:

(a) The actual marshaling process must be accomplished in the shortest possible time.

(b) Most of the preparation for the operation must be completed prior to the marshaling. For instance, units should obtain as early as practical (in the mounting process) the supplies and equipment that are to accompany them into the objective area.

### b. Phases of supply.

(1) Delivery of the accompanying supplies is the first of the supply phases in an airborne operation. Accompanying supplies are classified as unit prescribed loads and as additional supplies. Unit prescribe loads are delivered into the airhead on individuals, on organic vehicles, and by airdrop and air landing. Quantities should be sufficient to sustain operations until resupply can be accomplished. Units in both the assault and followup echelons carry accompanying supplies into the airhead. Additional supplies consist of the force reserve of class III, selected class II, class IV, and class IX items. These items are sent into the airhead by the force support command.

(2) The second phase is the followup, during which supplies are air landed or airdropped to units until routine supply procedures can be instituted. There are two types of followup supply—automatic and on-call.

(a) Automatic followup supplies are brought into the objective area on predetermined delivery schedules. They are based upon estimated daily expenditures and the need to buildup reserve stocks. The types and quantities of items included in automatic followup supply are determined by the force commander.

(b) On-call followup supplies are held in readiness in the departure area for immediate delivery to units on specific request. They consist of additional quantities of items included in the automatic followup category, essential major items of equipment, and supplies that are con-

\*Whenever possible, units should be so located during or prior to mounting as to preclude the necessity for movement to marshaling camps.

sumed at an unpredictable rate. The quantities and types are determined by the commander of the airborne force. On-call supplies may be segregated, packaged into type loads, or maintained in bulk pending emergency requests for specific types and amounts.

(3) The third phase is a routine supply. During this phase, supplies are delivered according to supply procedures; to replace expenditures or to buildup reserve stocks. The source of supply may be from the supporting logistical agencies or the supply points established subsequent to linkup.

*c. Supply Policies.* The quantities and types of equipment carried by assault airborne forces are dictated by the initial combat requirements as modified by the capability of the airborne unit to handle them, the available carrying capacity of aircraft, the projected time of force linkup and or withdrawal, weather, and enemy capabilities. Normally, any available space in aircraft can be used to carry additional supplies for forces already in the objective area. Documentation of supplies delivered to the airhead facilitates allocation and shifting of means of support to meet unexpected situations.

(1) Based on the above considerations, the Army commander normally determines the levels of supply for a particular operation. Generally, a 3-day level of supply in the airhead is desirable at all times; 2 days is considered the minimum safe level within the airhead.

(2) Assault and individual combat rations are carried by all airborne units entering the objective area. Combat rations are used for the followup supply phase. Filled water containers are carried for use en route and for consumption in the objective area. Location of probable water supply points is predetermined. Water purifica-

tion units are brought into the objective area as early as possible.

(3) Limited amounts of essential class II items are included in accompanying supplies. Minimum stocks of individual clothing and equipment are in followup and routine supply phases. Major items of equipment normally are included in additional and on-call followup supply phases, as required by the situation.

(4) Vehicles and machinery are enplaned with fuel tanks filled to the maximum safe level which is three-fourths full. Each vehicle carries additional fuel and lubricants. The main reliance for class III and class IIIA supply and resupply is on packaged products. This is particularly true during the initial stages of the operation when automotive fuels may be delivered in 5-gallon cans. During later phases of the operation, fuel may be delivered to the objective area in bulk. Prescribed reserves of automotive and aviation fuels are maintained in the objective area by supply and service units of the force. Aviation fuel is maintained at or as near airlanding facilities as possible.

(5) The amount of class IV and class VI supplies brought into the objective area is limited. Local resources are exploited to the maximum. Necessary class IV and class VII supply support for an operation can be reduced by careful selection of drop and landing zone to minimize requirement for heavy construction equipment and material.

(6) The amounts and types of class V supplies vary with almost every situation. Accordingly, unit prescribed loads must be designated for each operation. Required types of class V supply to allow continuity of combat operations are included in followup supply phase, but the tactical situation in the objective area may cause frequent changes from the types and amounts planned for delivery.

### Section III. AIRDROP

#### 2-7. Types of Airdrop

There are two types of airdrop—decelerated drops and free fall drops (fig. 2-1).

*a. Decelerated Drops.* There are two types of decelerated drops: high velocity and low velocity.

(1) High velocity drop systems are designed to retard the descent to a rate that will permit the use of standard energy dissipating materials to dissipate shock impact. The parachute used, a ring-slot parachute, limits the rate of descent to about 70-90 feet per second. This method is used

for delivery of such items as subsistence, packaged petroleum products, and ammunition.

(2) Low-velocity drop systems are designed to retard the rate of descent to about 30 feet per second at sea level on a standard day. Loads to be delivered by this means are specially prepared either by placing them in airdrop containers, or by rigging them on platforms. This method is used chiefly for fragile material and for such heavy items as vehicles and artillery.

*b. Free drop.* Free drop is the delivery of sup-

# TYPES OF AIRDROP



## DECELERATED DROPS

## FREE DROP

### HIGH VELOCITY

### LOW VELOCITY

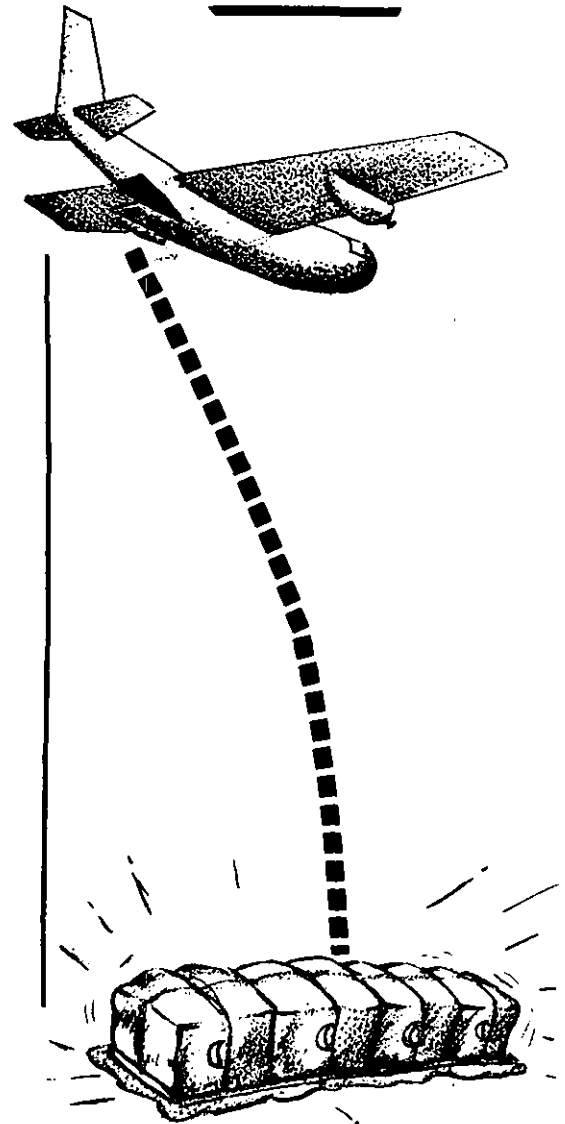
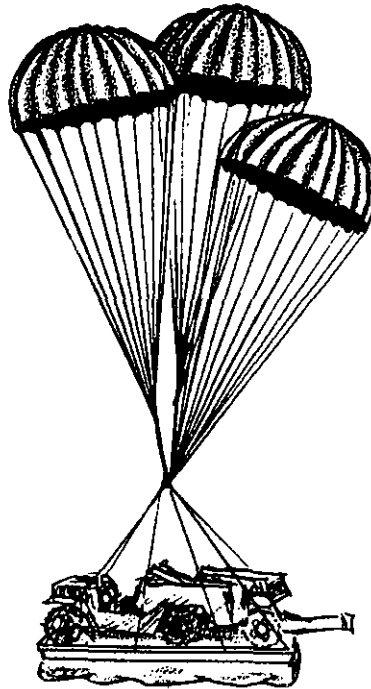
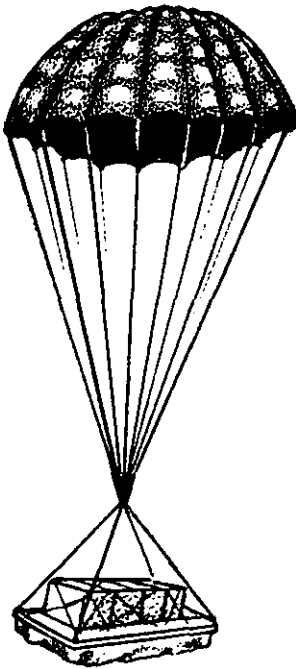

Figure 2-1. Types of airdrop.

plies and equipment from aircraft in flight without parachutes. Free drop is used for the delivery of fortification material, baled clothing, and other items which will not be appreciably

damaged on impact. Free drops are made from the lowest safe altitude. The rate of descent varies from 130-150 feet per second.

## 2-8. Methods of Release

Methods of releasing loads from aircraft are described in detail in TM 10-500 and summarized below:

*a. Door Load.* The door load method is the technique by which the load to be airdropped is pushed or skidded out of the door (cargo compartment) of the aircraft. It is applicable to both types of airdrop and to most aircraft.

*b. Wing Load.* In this technique, loads are rigged in containers and attached to wings of aircraft by bomb shackles or other devices. The wing load method is also adaptable to all three types of airdrop.

*c. Gravity.* In the gravity method of airdrop, the loadrestraining ties are released manually or

by a release parachute, allowing the load to roll out of the cargo compartment of the aircraft. This system applies to all rear-loading cargo aircraft.

*d. Extraction.* An extraction parachute pulls the load from the cargo compartment of the aircraft. This method is used for such items as artillery pieces, vehicles, special-purpose equipment, and bulk ammunition and supplies rigged on airdrop platforms.

*e. Helicopter Hookload.* In this method of airdrop, the load is suspended from a hook device on the helicopter, transported to the delivery area, and airdropped by releasing the load from the hook.

## CHAPTER 3

### AIRDROP SUPPLY COMPANY

---

#### Section I. GENERAL

##### 3-1. Mission

The mission of the airdrop supply company (TOE 10-407G) is to provide parachute packing, temporary storage, and the rigging of supplies and equipment for airdrop by Army, Air Force, or other service aircraft. The mission also requires the company to render technical assistance in the recovery and evacuation of airdrop equipment.

##### 3-2. Organization

The organization of the company, illustrated in figure 3-1, divides the company into the following elements:

*a. Control Elements.* The company headquarters and the airdrop office make up the command and control elements. Company headquarters provides the necessary command and supervision. The airdrop office coordinates and controls the requisitioning, receiving, and storing of airdrop equipment and supplies, including equipment to be rigged; the packing of parachutes and organizational maintenance of airdrop equipment; and the rigging and loading of supplies and equipment for airdrop.

*b. Operating Elements.* The operating elements are the four operating platoons. Each platoon consists of a platoon headquarters, a support section, and an airdrop section. Although the company is designed to be employed at a single location and to operate on two 10-hour shifts, each platoon can operate independently on a single shift is provided administrative and combat service support including messing facilities, organizational supply and maintenance, and operational supply support.

##### 3-3. Capabilities

The airdrop supply company is capable of—

*a.* Receiving, storing, and preparing selected items of all classes of supplies and equipment for airdrop on a daily basis as follows:

- (1) At 100% strength (level 1)—200 tons.
- (2) At 90% strength (level 2)—180 tons.
- (3) At 80% strength (level 3)—150 tons.

*b.* Operating a storage area containing selected items of all classes of supplies and equipment required for airdrop operations, as determined by the commander of the Field Army Support Command or of the Supply and Maintenance Command (SMC).

*c.* Performing organizational maintenance on airdrop equipment and providing direct exchange for personnel parachutes used in Army aircraft.

*d.* Assisting, as required, in loading supplies in aircraft for airdrop and in ejecting supplies from aircraft in flight.

*e.* Supplementing, when necessary, the capabilities of other units engaged in parachute packing, parachute maintenance, and airdrop operations; and providing technical assistance in the recovery and evacuation of airdrop equipment.

##### 3-4. Assignment and Allocation

Within the Field Army Support Command (FASCOM), the company is assigned to the army support brigade. Within the Theater Army Support Command (TASCOM), it is assigned to a designated field depot of the SMC. In either assignment, it will normally be attached to a Headquarters Company, Supply and Service Battalion, TOE 29-146. Companies are allocated to TASCOM and FASCOM as required.

##### 3-5. Operational Controls

Airdrop support missions for companies operating out of COMMZ are coordinated through the inventory control center (ICC) of the Supply and Maintenance Command (SMC). Missions for companies in the field army area are coordinated through the ICC of the Field Army Support Command (FASCOM). If field army requirements exceed the capabilities of assigned airdrop units, requirements are transmitted from FASCOM ICC to SMC ICC.

*a.* In the COMMZ, the ICC performs stock control functions for the airdrop supply company and relieves it of the responsibilities to requisition material to be airdropped. In the field army,



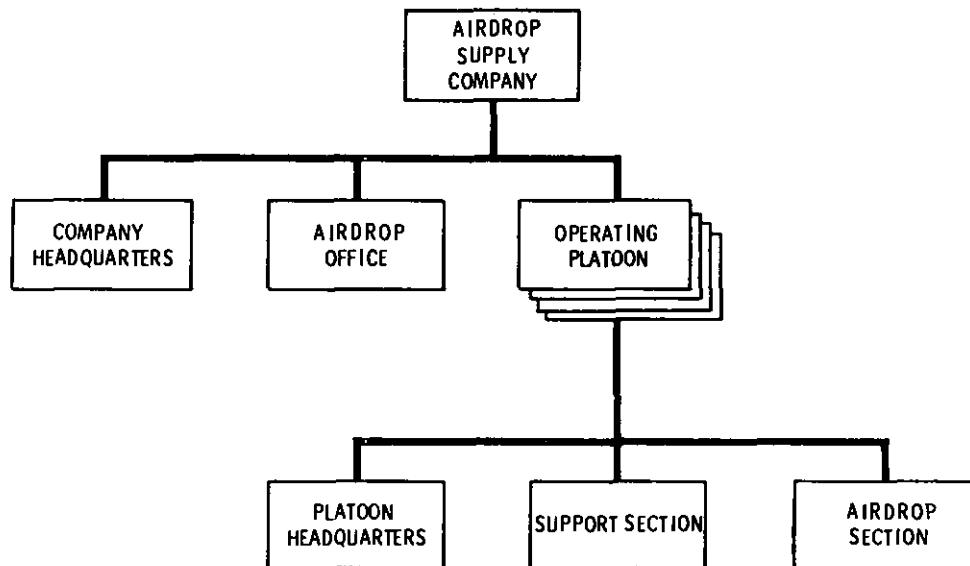

Figure 3-1. Airdrop supply company.

stock control center of the army support brigade performs the stock control functions for the airdrop supply company.

b. In both the COMMZ and field army, the ICC coordinates the preliminaries of each airdrop

supply mission with the Movements Control Center (MCC) and passes the operating instructions to the airdrop supply company. These instructions include quantity, weight, cube, and the time and place for prepared loads to be ready for the aircraft.

## Section II. COMPANY ACTIVITIES

### 3-6. General

Company activities such as the inspection, packing, and repair of parachutes, and the rigging of supplies and equipment for airdrop are performed according to standing operating procedures developed in accordance with approved techniques. There are, however, certain company activities which must be adapted to specific situations and to requirements imposed by local conditions. For these activities, which include the selection of rigging areas and company layout, only the broadest guidance can be provided.

### 3-7. Selecting Operating Sites

The command to which the company is assigned designates the general area in which the company is to operate. Within this general area, the company commander will select suitable operating sites in consideration of mission facilities, location of supply installations and air terminals, road nets and transportation. Unless tactical considerations or directives from higher headquarters prevent it, rigging operations should be

performed at or near the departure airfield. Such a location has the following advantages:

- a. It eliminates multiple handlings.
- b. Reduces the requirement to have materials handling equipment available at the rigging area and at the terminals.
- c. Reduces the amount and size of transportation required to move the rigged supplies.

### 3-8. Layout and Space Requirements

a. *Layout.* The company commander should develop a plan for the layout of the company. Some form of shelter should be provided for operations requiring protection from the weather. Temporary buildings should be erected when permanent buildings are not available. If buildings are not available, tents should be requisitioned to provide necessary shelter. Establish appropriate fencing requirements or other effective security control requirements for the control of casual or systematic pilferage of storage or other critical operating areas. See FM 19-30 for physical se-

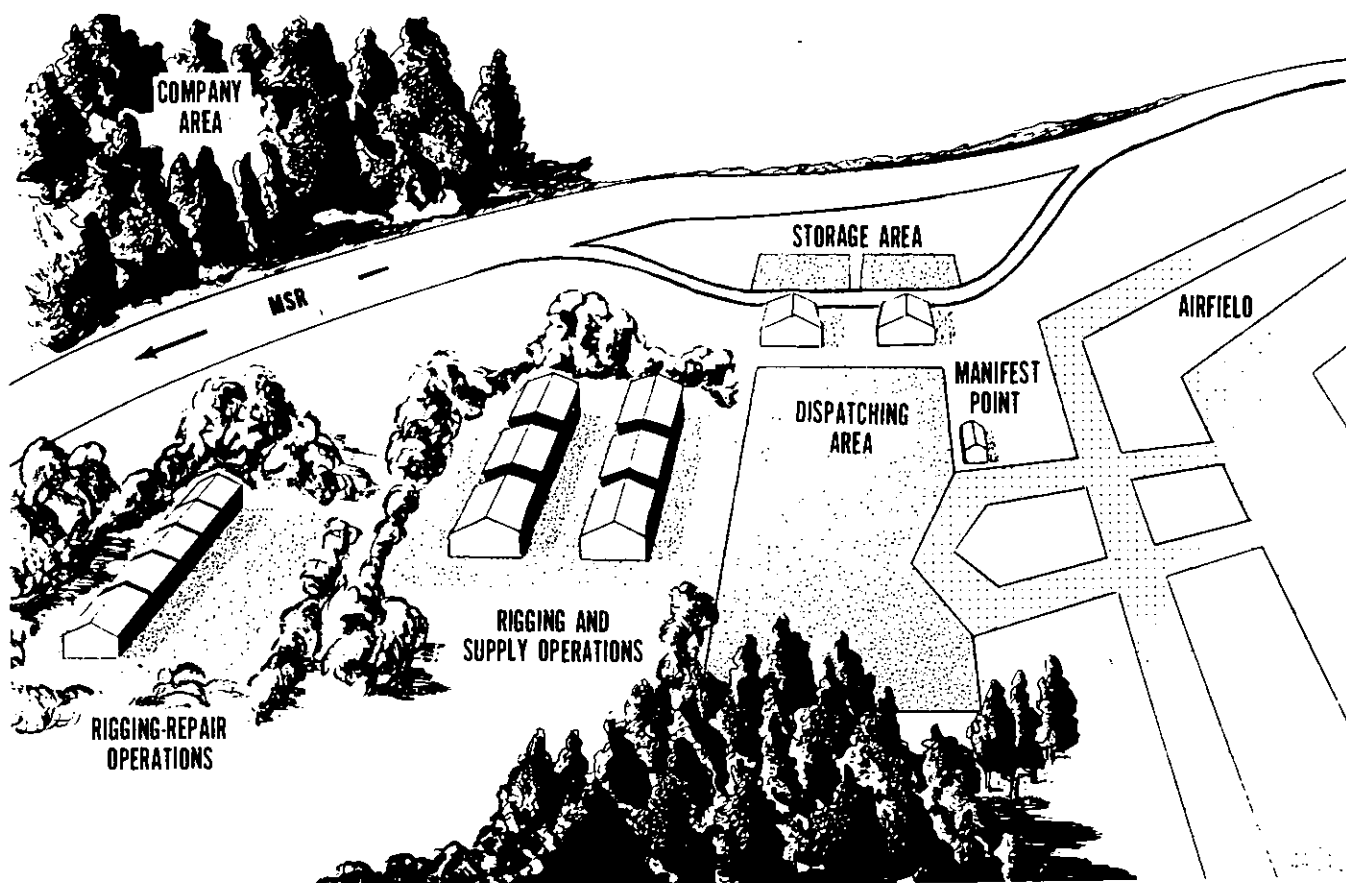

Figure 3-2. Layout of Airdrop Supply Company.

curity measures or safeguards. A suggested layout appears as figure 3-2.

*b. Location.* The site selected by the company commander for company operations should be reasonably high, with slopes affording good drainage. Gravel should be used, if possible, to cover paths and roadways. The best terrain may become muddy under heavy traffic in rainy weather. In cold weather, the company should be located in an area in which natural protection is provided against wind and cold. In hot weather the location selected should permit as much air circulation as possible.

*c. Space Requirements.* Exact space requirements for the company must be determined on the basis of assigned mission, stock levels, and other logistic considerations. The quantities of equipment and supplies required to be stored and the working space necessary for packing, maintenance, and rigging operations demand a rela-

tively large operating site. Based on the quantities of material authorized by the TOE, estimated requirements total approximately 380,000 square feet. Suggested procedures for space computation are contained in FM 101-10-1 and TM 743-200.

(1) Company headquarters should be as close to the operating area as possible. For planning purposes, an estimated 80,000 square feet is required for the company headquarters layout. The layout would include the unit supply area, orderly room, living quarters, dining area, and automotive maintenance and parking area.

(2) Maintenance and packing operations will require the equivalent of several buildings with approximately 20,000 square feet of floor-space. Considerable floor-space will be occupied by packing tables arranged in 48- or 60-foot Large cargo parachutes normally are packed on the floor; sufficient floor-space must therefore be made available for such packing operations. Pro-

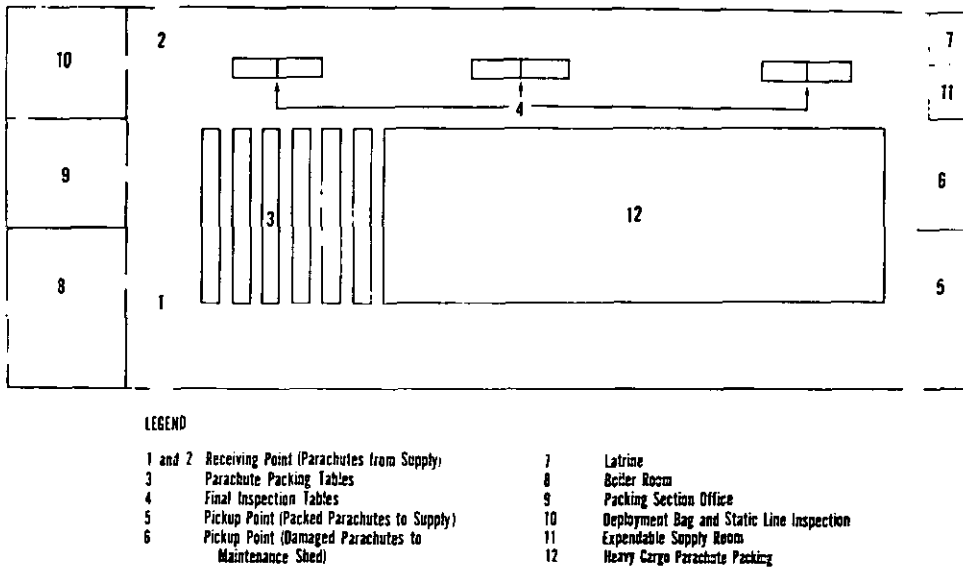

Figure 3-3. Layout for Parachute Packing Shed.

vision must be made for issuing maintenance supplies. A suggested layout for a packing shed is shown in figure 3-3.

(3) Airdrop operations will require at least 80,000 square feet of covered space for organizational equipment and for operating supplies requiring protective storage. In addition, approximately 200,000 square feet of outside space will be needed for rigging operations and for the receipt and storage of airdroppable supplies not requiring indoor storage.

(4) A manifest shed or tent should be erected near the dispatching area and loading strip.

It is at this point rigged supplies and equipment are grouped into assigned aircraft loads.

(5) Temporary outdoor storage areas may be necessary for certain phases of company operations. Rigged supplies for an airdrop mission may require storage overnight or even for days, depending on weather conditions, tactical situations, and logistical requirements. In such cases, the dispatching area or adjacent storage area may be used. Supplies and equipment should be stored in such a manner as to be protected against weather, vermin, theft, sabotage, fire, and enemy observation.

### Section III. OPERATIONS

#### 3-9. Support Sections

The support sections of the operating platoons are concerned with inspection, packing, organizational maintenance, and storage of parachutes and related equipment. To the extent possible, section leaders should so employ personnel that each packer and repairman becomes familiar with all section activities. Unless local conditions require some other arrangement, the activities of the sections should be directed, controlled, and coordinated by the airdrop office.

a. Airdrop equipment required for operations is supplied by the air equipment repair and supply company. The quantity of airdrop equip-

ment included in the TOE represents a training allowance. Items required for conduct of airdrop operations are considered class IV, and are requisitioned by the airdrop supply company in the quantities and types required by assigned missions and/or projected workload.

b. The support sections include personnel to inspect, classify, and perform limited organizational maintenance on airdrop equipment organic to the company, or that damaged in transit from the supplying depot. Maintenance personnel inspect all damaged airdrop equipment to determine the extent of repairs required. Items falling within the criteria for organizational maintenance and

### LOAD BREAKDOWN CHART (AIRDROP)

Mission No. <b>170</b>		Grids <b>UP 559091</b>			Estimated Drop (Date and Time) <b>0840-31 Jan 69</b>			Page <b>1</b> of <b>1</b> Pages			
								Date <b>30 Jan 69</b>			
Quantity Requested	Item	Quantity per Package	Required No. of Packages	Total Quantity Packed	Item Wt. per Package	Total Item Weight	Type of Conts.	Packs. per Cont.	Load Wt. in Cont.	Total Cont. Wt.	No. of Conts.
1	3/4-Ton Truck	1	1	1	5,800	5,800	Assy	1	5,800	7,772	1
2	105mm how	1	1	1	5,000	5,000	Assy	1	5,000	6,525	1
3	1,300 rds 105mm Ammo	3	30	90	171	5,130	L/B	30	5,896	7,500	1/3 A
4											
5											
6											
7											
8											
9											
10											
11											
12											
13											
14											
15											

Signature *E. G. Carlin, CW4*

Figure 3-4. Load breakdown chart (suggested).

workload capabilities of the unit are repaired and placed in stock. Others are evacuated to the supporting airdrop equipment repair and supply company.

c. The flow of work through the packing and repair areas should be set up on a production line basis. When buildings are available, the development of a workflow pattern is a relatively simple matter. If, however, buildings are not available, or are widely separated, considerable planning and improvisation are required to produce the best possible workflow plan.

### 3-10. Airdrop Sections

The airdrop sections of the operating platoons are responsible for rigging supplies in airdrop containers, and for rigging vehicles and other equipment for airdrop on platforms and platform assemblies. Rigged loads may be delivered by United States Air Force or Army aircraft or by aircraft made available from other sources. This imposes a requirement for coordination between the company and the appropriate carrier agency, particularly in regard to time schedules, weight and space limitations, and the need for company personnel to accompany the load. This coordination results not only in the interchange of information necessary to determine the manner in which individual loads must be rigged, but also allows the company to make use of load association data which indicate elements of loads that should be dropped together and loads that may be dropped separately. An artillery piece and its prime mover, for example, must be used together on the ground and represent, therefore, an associated load which should, all conditions permitting, be dropped from the same aircraft.

a. The inventory control center prescribes the level of supplies and equipment which the unit prepares for airdrop. When operating apart from a supply installation, the unit may maintain a 3- to 5-day level of class I, III, and V supplies, and selected items of all other classes of supply. When operating at or adjacent to a supply installation, the levels of supplies maintained are reduced to the minimum compatible with efficient operations.

b. When airdrop requests are received, rigged loads are taken from storage, parachutes attached, and the loads transported to aircraft for loading. Action is taken by the ICC, when nec-

essary, to replenish the items shipped. The incoming replenishment supplies are rigged and stored to meet further airdrop requests. The Airdrop Supply Company must request the replenishment of airdrop equipment. This is necessary because the ICC will not be able to determine what airdrop items of equipment are used on any specific mission.

c. The ICC, having complete data on resources, assures the sufficiency of cargo materiel at the airdrop supply company operating point and directs delivery to the aircraft or air terminal. It also takes any action necessary to reestablish the storage of the air drop supply company.

### 3-11. Recovery Procedure

The receiving unit is responsible for the recovery and evacuation of airdrop equipment to the maintenance facility as designated in applicable administrative orders. A recovery officer, normally appointed by the receiving unit, will direct recovery of airdrop equipment after supplies are retrieved. Personnel from the support section of the airdrop supply company may be airdropped following the supplies to provide technical advice to the receiving unit.

### 3-12. Container and Platform Loads

Detailed information on the make-up of airdrop container and platform loads, weight limitations for airdrop containers, types of items to be rigged in containers and on platforms, and parachute and cushioning material requirements is contained in TM 10-500-series. These manuals also indicate, in general, factors and considerations to be taken into account in load preparation.

a. At level 1 the company has the capability to prepare 200 tons of supplies daily for airdrop. Approximately 65 percent of the tonnage prepared daily will be bulk supplies of all classes.

b. The airdrop officer prepares a load breakdown chart which serves as the basic control document for the rigging operation. The chart should be locally reproduced and should contain as a minimum the information contained on the form suggested in figure 3-4. The number of copies required for each operation varies. One copy must be provided each team rigging the loads and one copy for the reports clerk at platform headquarters. His copy becomes the work-sheet for the preparation of the flight manifest for each aircraft.

## CHAPTER 4

### AIRDROP EQUIPMENT REPAIR AND SUPPLY COMPANY

#### Section I. GENERAL

##### 4-1. Mission and Assignment

The mission of the Airdrop Equipment Repair and Supply Company (TOE 10-417G) is to operate a depot for supply, direct and general support maintenance, and reclamation of airdrop equipment. The company is assigned to the Supply and Maintenance Command and normally attached to Field Depot. Airdrop equipment repair and supply companies are located on the basis of one company per Airdrop supply Company and one per airborne division at level 3.

##### 4-2. Organization

The airdrop equipment repair and supply company is organized, as shown in figure 4-1, into a company headquarters, two parachute and textile repair platoons, and an airdrop supply and service platoon.

a. Company headquarters is responsible for the effectiveness of company operations; supply, mess, training, and housing of company personnel; and the maintenance of organic equipment and weapons.

b. The parachute and textile repair platoon is organized into a platoon headquarters and two parachute and textile repair sections. The platoon provides both direct and general support level maintenance for airdrop equipment, less platforms.

c. The airdrop supply and service platoon is responsible for the receipt, storage, and issue of airdrop equipment, and provides for the receipt, classification, and disposal of unserviceable equipment. It also provides organizational maintenance on sewing machines, vehicles, generators, platforms, and organic company equipment.

The above responsibilities are divided between the platoon's airdrop supply section and service and classification section as follows:

(1) The airdrop supply section receives the incoming supplies and stores and issues them.

(2) The service and classification section receives, inspects, and classifies all airdrop equipment turned in by supported units. Serviceable items are placed in stock for reissue. Economically repairable items are delivered to the appropriate sections of the parachute and textile repair platoon. Scrap and items that cannot be economically repaired are salvaged or cannibalized.

##### 4-3. Capabilities

a. The company is capable of—

(1) Receiving, classifying, and performing direct and general support level maintenance on airdrop equipment in support of one airdrop supply company.

(2) Requisitioning, receiving, storing, and issuing airdrop equipment.

(3) When necessary, supplementing the parachute packing and maintenance activities of other units engaged in airdrop of personnel and equipment.

(4) Performing direct and general support level maintenance on airdrop equipment utilized in Army aircraft.

(5) Maintaining a prescribed level of airdrop equipment.

b. The company, at level 3 (80% strength), is capable of supporting an airborne division (or equivalent airborne force).

#### Section II. COMPANY ACTIVITIES

##### 4-4. Site Selection

The general operating area for the company is normally designated by the controlling headquarters to conform with the overall operational plan of the command. Within this general area, specific sites for company headquarters and operating

elements of the company are determined by the company commander. Factors influencing the decision are terrain, defensibility, and existing conditions in the general area designated for the company.

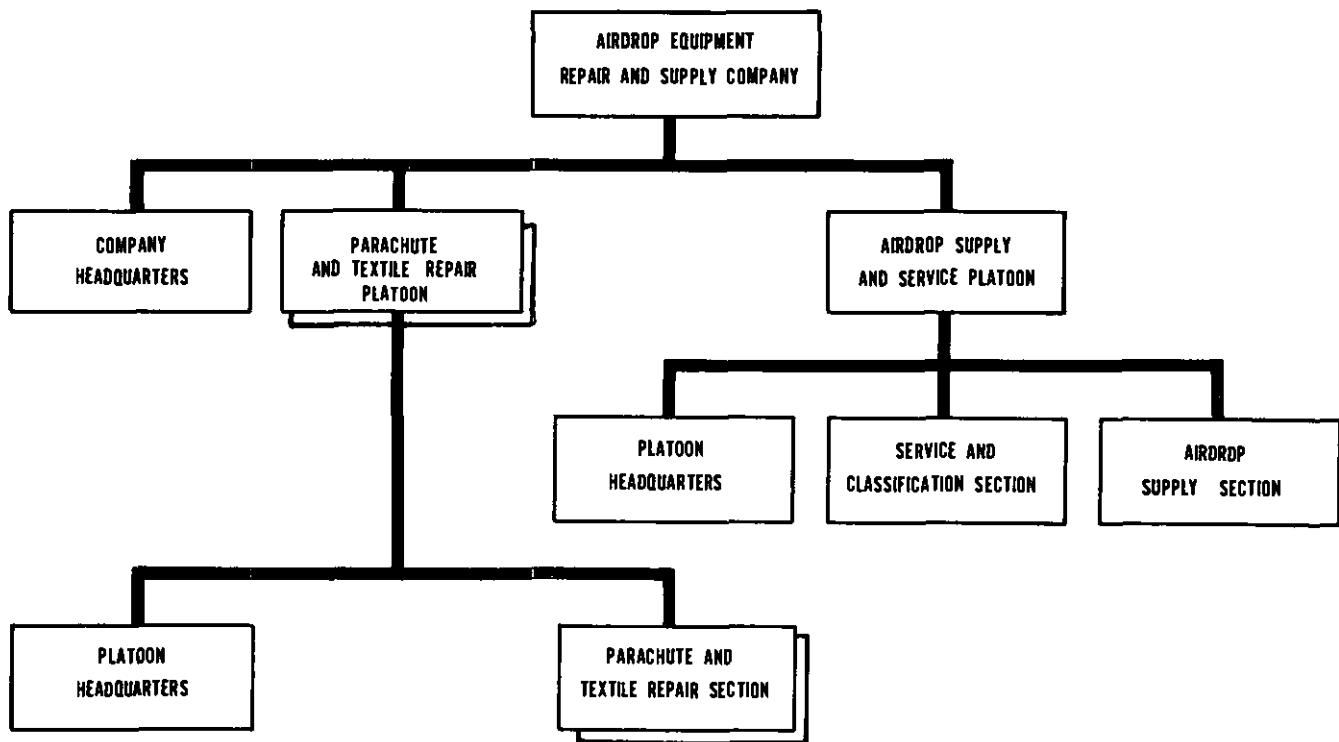

Figure 4-1. Airdrop equipment repair and supply company.

a. Most important is the mission of the company and the special requirements that characterize company operations. Because the company employs equipment that requires shelter, the conversion and availability of existing structures are prime considerations. It may be necessary to erect temporary buildings if existing ones cannot be modified or rehabilitated. Tents can be requisitioned for operations and supplies that require protection from the elements. Availability and capability of facilities for providing power must also be taken into account.

b. The availability of transportation facilities is another major consideration. The company should be located as close to main road and rail nets as dispersion requirements will permit.

#### 4-5. Layout and Space Requirements

a. The layout for the company is determined by the company commander. It is based on the specific mission to be performed, size and characteristics of the operating site, and the type of operation (fig. 4-2).

b. It is estimated that all company operations can be performed in an area of approximately 40,000 square feet. Expressed in terms of building requirements, this figure indicates that the

operating elements of the company would require six 48' X 112' buildings. These space requirements are presented for guidance only.

c. The following considerations generally are applicable when making the layout:

(1) Company headquarters area should be located as close as possible to the operating area. It should contain the company supply room, orderly room, messhall, living quarters, and vehicle parking area.

(2) Within the airdrop supply section area, warehouses and buildings should be located next to a railroad siding and be surrounded by hard-top surfaced area. An open storage area may be maintained for items not affected by exposure to the elements. Requirements for adequate mechanical aids to security, to include perimeter barriers, protective lighting system, alarm system, and communications must also be determined for planning purposes.

(3) The maintenance area should be arranged to provide for the most effective repair procedures. It must be set up to accommodate parachute, textile, wood, and metal repair activities.

(4) The parachute and textile repair shop may be in a separate building or in a designated

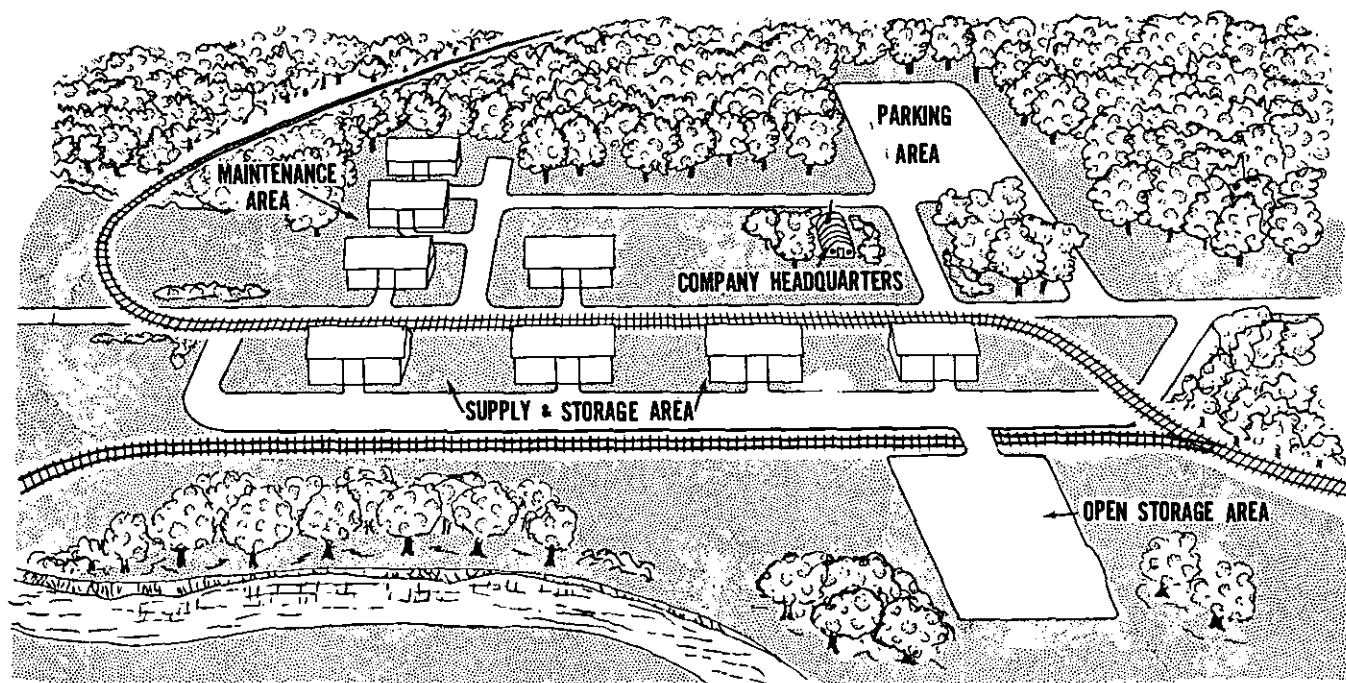

(39-1/2 PICAS)

Figure 4-2. Layout of airdrop equipment repair and supply company.

part of one building that accommodates the company's entire maintenance operation. Parachute and textile items should be kept in covered facilities preceding, during, and following repair. The parachute and textile repair shop should include—

(a) *Bins for items received.* These bins should be constructed with a smooth finish and labelled for storage and segregation of air delivery equipment.

(b) *Shakeout area.* For personnel, extraction, and cargo parachutes, a shakeout area is provided. This may be an indoor shakeout room or an outdoor shakeout tower.

(c) *Initial inspection area.* This area should include a shadow inspection table for the inspection of parachute canopies and a worktable for the layout of the parachutes. Four packing tables should be used for inspection of other textile and fabric items to be repaired. The shadow inspection table should be convenient to parachute storage bins in order to decrease handling requirements.

(d) *Machine and work area.* This area contains sewing machines, tables, and bins. All machines except one in the special machines area

should be located adjacent to a worktable. In the work area, a table is used for grommet setting and other light hardware repairs. Items of equipment awaiting final inspection are put in smooth-finished bins near the final inspection table. The bins are marked for convenient and accurate sorting of items.

(e) *Final inspection area.* This includes tables for the inspection of parachutes and loose items. A copy of the operating procedure for final inspection should be attached to each table. Loose items that have received final inspection should be sent to storage. Personnel parachutes that have received final inspection are rigger-rolled and sent to storage. After final inspection, cargo parachutes are rigger-rolled, inserted in deployment bags and then sent to storage.

#### 4-6. Workflow

The company commander must plan the workflow in such a manner as to gain the most effective results from available facilities. He should, if possible, plan his workflow and layout at the same time since the work flow will depend upon the type and condition of facilities the company uses in performing its operations. If, for example, all operating elements of the company were to be located in a single building, he may



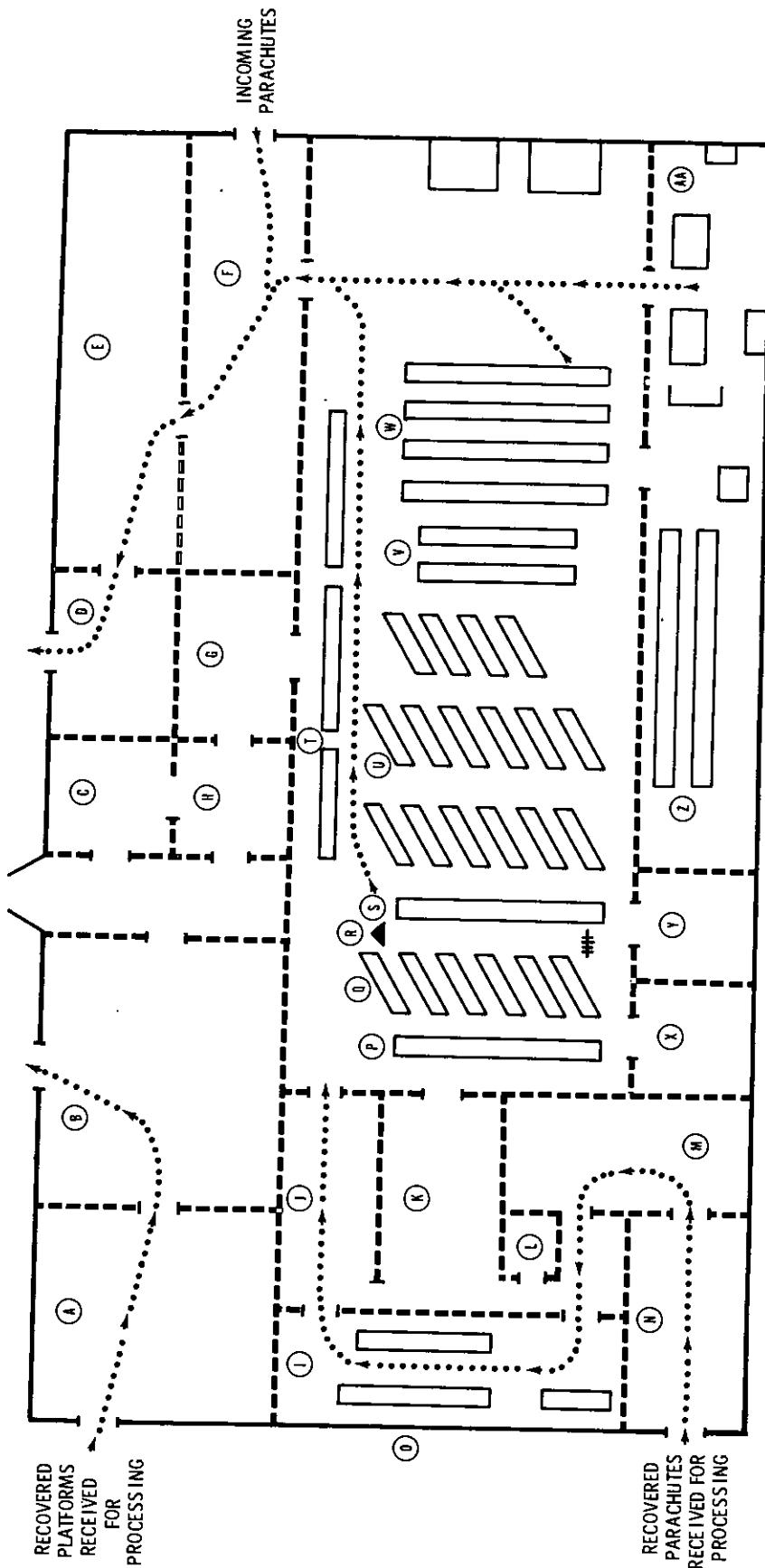

- A - PLATFORM REPAIR
- B - PLATFORM STORAGE AND ISSUE
- C - SHOP MAINTENANCE
- D - PARACHUTE ISSUE
- E - PARACHUTE STORAGE PRIOR TO ISSUE
- F - PARACHUTE RECEIPT
- G - ADMINISTRATIVE OFFICE
- H - SHOP OFFICE
- I - CLASSIFICATION AND DEMILITARIZATION
- J - PERSONNEL PARACHUTE BACKLOG
- K - CARGO PARACHUTE BACKLOG
- L - SALVAGE
- M - INDOOR SHAKEOUT TOWER
- N - INCOMING STORAGE (AWAITING SHAKEOUT AND/OR CLASSIFICATION)
- O - OUTDOOR SHAKEOUT TOWER
- P - CARGO PARACHUTE INITIAL INSPECTION
- Q - CARGO PARACHUTE REPAIR
- R - CARGO PARACHUTE LINE REPLACEMENT
- S - CARGO PARACHUTE FINAL INSPECTION
- T - PERSONNEL PARACHUTE INITIAL INSPECTION
- U - PERSONNEL PARACHUTE REPAIR
- V - PERSONNEL PARACHUTE LINE REPLACEMENT
- W - PERSONNEL PARACHUTE FINAL INSPECTION
- X - PERSONNEL LOCKER ROOM
- Y - TOE GENERAL SUPPLIES
- Z - PARACHUTE PACKING AREA (PARTITIONED)
- AA - COMPONENT REPAIR

Figure 4-3. Suggested shop layout and workflow plan.

design a workflow similar to that shown in figure 4-3. If, however, the platoons and sections must operate in separate buildings, it will be neces-

sary to plan the flow of work to fit the type and number of buildings and to take into consideration the distances between the buildings.

### Section III. MAINTENANCE OPERATIONS

#### 4-7. General

*a.* Maintenance operations consist of the inspection, classification, renovation, and return of airdrop equipment to stock. The operation also includes, when required, performance of modification work orders on airdrop equipment.

*b.* The company employs two operating methods—the production-line method and the bay shop method. The method used depends upon the materiel to be repaired and the personnel, facilities, and time available. Frequently, a combination of both methods may be employed.

*c.* In an operating situation, the parachute and textile repair platoon headquarters administers and controls the maintenance operations of the platoon, and can be regarded as a shop office. In this capacity, its functions include the following:

- (1) Assigning work to and coordinating activities of the repair sections.
- (2) Routing and controlling the flow of work to the repair sections.
- (3) Employing production control methods to include the following:
  - (*a.*) Reroute work, when necessary, to best utilize the capabilities of all repair sections.
  - (*b.*) Temporarily reassign personnel to meet workload demands.
  - (*c.*) Take appropriate action to expedite the delivery of maintenance operating supplies to meet demands.
  - (*d.*) Arrange for the prompt evacuation of materiel as required.
- (4) Maintaining required production records and reports.

*d.* Within the parachute and textile repair sections, a section chief is responsible for the proper movement, control and performance of work. They perform, or supervise the performance of, the following:

- (1) Equalizing workloads by the assignment of jobs to the various teams within the section.
- (2) Coordinating the work of the various teams of the section.
- (3) Reassigning personnel from one job to another to obtain the best productive effort, and

maintaining a system of cross-training to facilitate such reassignment.

(4) Conducting in process inspections to assure that work is being performed properly.

(5) Keeping the shop office informed of the progress of each job, changes in the status of each job, and any major problems.

(6) Ordering parts that are required for specific jobs when the requirements for such parts were not determined by individual inspection.

#### 4-8. Production Control

*a. General.* Production control involves directing and controlling work flow. It requires the application of common sense, effective planning, close supervision, prompt remedial action, and necessary tools to direct and control the flow of work in a manner that results in a maximum output of quality work. This is accomplished by balancing the workload within the company to eliminate overloads or under loads, by keeping abreast of the status and quantity of work in order to prevent bottlenecks, by controlling the quality of work performed by repairmen, and by improving operational procedures.

*b. Procedure.* Production planning and control operations vary from one airdrop equipment repair and supply company to another, for no one system can satisfy the requirements of all conditions.

*c. Aids.* Effective production control demands prompt action based on current and readily available information. It requires a continuous flow of current data from all sections of the unit.

*d. Implementation.* Section chiefs and supervisors are responsible for seeing that production control measures are properly implemented within the repair sections.

#### 4-9. Quality Control

Inspection constitutes one of the most important aspects of the maintenance function. It is the means by which the commander can control the quality of work done in the platoon. Personnel selected for inspection duty should be highly skilled repairmen able to diagnose deficiencies in a piece of equipment, prescribe necessary re-

pairs, and accurately determine the adequacy of the repairs performed.

a. Material should be thoroughly inspected upon receipt to determine whether it is repairable or should be salvaged. If an item is to be repaired, all essential repairs must be specified on the job order. The inspector decides whether defective components or assemblies will be replaced or repaired. His determination is based upon the time and equipment necessary for each operation and the availability of maintenance supplies.

b. In-process inspection is extremely important.

Emphasizing such inspections will significantly reduce the frequency of rejections by final inspectors. It is often easier to detect potential deficiencies while the repair of equipment is in progress than to find them after the work has been completed. Often, when equipment is dismantled, deficiencies can be noted which may not be detected at any other time.

c. Every piece of material must be inspected prior to its release from the company. The final inspection is the most important means of controlling the quality of the work.

## Section IV. SUPPLY AND STORAGE OPERATIONS

### 4-10. Supply

Supply operations performed by the airdrop supply section of the airdrop supply and service platoon can be classified as organizational supply, shop supply, and technical supply. Organizational supply includes the operations concerned with obtaining and replenishing individual and organizational supplies and equipment. Shop supply includes all the functions required to receive and store material the company needs to perform its repair (maintenance) mission. Technical supply is the receipt, storage and issue of airdrop items required by supported units.

### 4-11. Storage

Personnel of the airdrop supply section must be familiar with Army storage procedures. Time and spacesaving methods must be used. Procedures for storage are contained in TM 743-200. Inspections of stored items must be made frequently to reveal and correct supply deterioration, faulty warehousing, fire hazards, and other deficiencies.

## APPENDIX A

## REFERENCES

**A-1. Army Regulations (AR)**

- 59-106 Operation of Air Force Air Terminals.  
 310-25 Dictionary of United States Army Terms.  
 310-50 Authorized Abbreviations and Brevity Codes.  
 611-101 Manual of Commissioned Officer Military Occupational Specialties.  
 611-201 Enlisted Military Occupational Specialties.

**A-2. Department of the Army Pamphlets (DA Pam)**

- 310-1 Index of Administrative Publications.  
 310-2 Index of Blank Forms.  
 310-3 Index of Doctrinal, Training, and Organizational Publications.  
 310-4 Index of Technical Manuals, Technical Bulletins, Supply Manuals, Supply Bulletins, and Lubrication Orders.  
 310-6 Index of Supply Catalogs and Supply Manuals.  
 310-7 U.S. Army Equipment Index of Modification Work Orders.

**A-3. Field Manuals (FM)**

- 1-100 Army Aviation Utilization.  
 19-30 Physical Security.

- 29-50 Supply and Services in Divisions and Separate Brigades.  
 54-3 The Field Army Support Command.  
 54-4 The Support Brigade.  
 54-7 The Theater Army Support Command.  
 55-6 Transportation Services in Theaters of Operations.  
 55-10 Army Transportation Movements Management.  
 55-46-1 Army Air Transport Operations.  
 (Test)  
 57-1 U.S. Army/U.S. Air Force Doctrine for Airborne Operations.  
 100-10 Combat Service Support.  
 100-27 U.S. Army/U.S. Air Force Doctrine for Tactical Airlift Operations.  
 101-10-1 Staff Officers' Field Manual: Organizational, Technical, and Logistical Data (Unclassified Data).

**A-4. Technical Manuals (TM)**

- 10-500 series Airdrop of Supplies and Equipment.  
 10-1670 series Organization, Field, and Depot Maintenance, Air Delivery Equipment.  
 743-200 Storage and Materials Handling.

## APPENDIX B

### DUTIES OF COMPANY PERSONNEL

---

#### B-1. General

This appendix discusses the duties of personnel in the airdrop supply company (TOE 10-407G) and in the airdrop equipment repair and supply company (TOE 10-417G). For the most part, duties are generally apparent from job titles listed in the TOE and the corresponding descriptions set forth in AR 611-101 and AR 611-201. The TOE indicates personnel who are required to be qualified parachute riggers on jump status. There are also additional duties indicated for some personnel. A responsibility of the company commander, among other things, is to impress on all concerned the use of organic weapons against low altitude air threat (app D).

#### B-2. Airdrop Supply Company

*a. Company Commander.* The company commander directs and supervises the operation and employment of the company. He is responsible for the administration, training, discipline, and supply of the company. He is assisted in these duties by the first sergeant. The motor sergeant, mess steward, and supply sergeant are the principal supervisory personnel in company headquarters. The motor sergeant, mess steward, and supply sergeant are the principal supervisory personnel in company headquarters. The motor sergeant supervises the mechanics and helpers who perform organizational maintenance on the vehicles, materials handling equipment, and power generating equipment provided the company. The mess steward supervises cooks and other mess personnel in the preparation and serving of company meals. The supply sergeant is responsible for the receipt, storage, and issue of company supplies and the operation of the company supply room. He is assisted by the armorer.

*b. Airdrop Office.* The airdrop office, who heads the airdrop office, is the company commander's principal technical assistant. He is responsible to the company commander for coordinating the requisition, receipt, and storage of airdrop equipment and supplies; the supplies and equipment to be rigged for airdrop; the packing of parachutes

and organizational maintenance of airdrop equipment; and the rigging and loading of supplies and equipment for airdrop. His chief assistant is the airdrop chief, who is the immediate supervisor of the noncommissioned and enlisted personnel assigned to the office.

*c. Platoon Leaders.* Platoon leaders are responsible to the company commander for the technical performance and military control of platoon personnel, the state of training of the platoon, and for the proper performance of assigned tasks. The platoon sergeant is the platoon leader's principal enlisted assistant.

*d. Airdrop Equipment Technicians.* The airdrop equipment technicians are the supervisors of the support and airdrop sections. They plan work assignments, and assign personnel and equipment to specific tasks. When the platoon operates on a shift basis, a parachute packer-supervisor assigned to each support section directs activities on one shift. Each airdrop section contains an ammunition storage inspector and a storage supervisor, who direct the receipt, storage, and issue of supplies and equipment to be rigged for airdrop. They also supervise the specialists, equipment operators, and supply handlers who physically handle the supplies within the storage area. The senior airdrop specialist supervises the personnel who rig supplies and equipment for airdrop.

#### B-3. Airdrop Equipment Repair and Supply Company

*a. Company Commander.* The company commander and personnel who compose company headquarters perform the administrative, supply, maintenance, and housekeeping functions in support of the company. The company commander directs and supervises the operation and employment of the company. He is responsible for the training and discipline of the unit. The first sergeant, supply sergeant, and mess steward are the principal supervisory personnel within the company headquarters.

*b. Parachute and Textile Repair Platoon.* Platoon headquarters consists of a platoon leader, platoon sergeant, and a reports clerk. The platoon leader commands the platoon and directs and supervises the maintenance of airdrop equipment. The platoon sergeant assists the platoon leader in planning, coordinating, and supervising the work of the platoon. The reports clerk maintains daily production records, flow charts and status boards, and submits reports as required.

(1) The parachute repair foreman, directs and supervises personnel engaged in inspecting and repairing parachutes and airdrop containers. He plans work assignments, determines additional requirements for personnel and equipment, and assigns personnel and equipment to meet assigned workloads.

(2) The inspector-testers and their assistants perform initial and final inspections and tests on parachutes and textile components of airdrop equipment.

(3) The senior parachute repairman, parachute repairmen, and parachute repair assistants, individually or in teams, perform the required maintenance.

*c. Airdrop Supply and Service Platoon.* The airdrop equipment supply officer commands the platoon and supervises the service and classification activities of the platoon, as well as the receipt, storage, and issue of supplies. He is assisted by the platoon sergeant in planning, coordinating, and supervising platoon operations.

(1) The service-classification technician supervises the service, classification, and disposal activities of the service and classification section. He also supervises the organizational maintenance of company equipment.

(a) The classifiers and assistants, the packingcrating specialist, and the forklift opera-

tor assist in the inspection, classification, and disposal of airdrop equipment. They also deliver items to be repaired to the maintenance elements, and assist the supply section in receiving and shipping activities, as required.

(b) The senior metal repairman, metal repairmen, and the metal repair helper fabricate metal parts and repair metal components of modular platforms.

(c) The airdrop equipment repairman and airdrop equipment repair assistant repair and maintain non-textile load rigging components and assist other repairmen as required.

(d) The electrician installs and maintains the electrical system providing power for the operation of sewing machines and other equipment. The powerman installs, operates, and performs organizational maintenance on motors, generators, and allied control and starting equipment used by the company.

(e) The power generator, mechanic, the light equipment repairman and his helper, and the wheel vehicle repairman perform organizational maintenance on equipment and vehicles assigned to the company.

(2) The airdrop supply officer, assisted by the airdrop equipment supply supervisor, directs and supervises the receipt, storage, and shipment or issue of airdrop equipment. He also supervises personnel computing the requirements for operating supplies.

(a) The airdrop equipment supply specialist identifies and coordinates the requisitioning, classification, and issue of airdrop repair parts and maintenance operating supplies.

(b) The airdrop equipment supply supervisor, assisted by the receiving-shipping specialist, receiving-shipping assistant, and forklift operator, supervises the receipt and shipment of supplies and equipment handled by the section.

## APPENDIX C

### CLASSES OF SUPPLY

---

<i>MAJOR CLASSIFICATION</i>	<i>SUBCLASSIFICATION</i> <sup>1</sup>
CLASS I—Subsistence	A—Air (inflight rations) R—Refrigerated subsistence S—Nonrefrigerated subsistence (less combat rations) C—Combat rations <sup>2</sup> B—Ground support materiel <sup>3</sup>
CLASS II—Clothing, individual equipment, tentage Organizational tool sets and tool kits, hand tools, administrative, and housekeeping supplies and equipment.	E—General supplies F—Clothing and textiles M—Weapons T—Industrial supplies <sup>4</sup>
CLASS III—POL: Petroleum fuels, lubricants, hydraulic and insulating oils, preservatives, liquid and compressed gases, bulk chemical products, coolants, de-icing and anti-freeze compounds, together with components and additives of such products, and coal.	A—Air W—Ground (surface)
CLASS IV—Construction: Construction materials to include installed equipment, and all fortification/barrier materials.	
CLASS V—Ammunition: Ammunition of all types (including chemical, biological, radiological, and special weapons), bombs, explosives, mines, fuzes detonators, pyrotechnics, missiles, rockets, propellants, and other associated items.	A—Air W—Ground
CLASS VI—Personal Demand Items Nonmilitary Sales Items)	

CLASS VII—Major End Items: A final combination of end products which is ready for its intended use; e.g., launchers, tanks, mobile machine shop, vehicles.

A—Air  
 B—Ground support materiel<sup>3</sup>  
 D—Administrative vehicles<sup>5</sup>  
 G—Electronics  
 K—Tactical vehicles  
 L—Missiles  
 M—Weapons  
 N—Special Weapons

CLASS VIII—Medical Materiel including Medical Peculiar Repair Parts.

CLASS IX—Repair Parts( less Medical Peculiar Repair Parts): All repair parts and components to include kits, assemblies, and subassemblies, reparable and nonreparable, required for maintenance support of all equipment.

A—Air  
 B—Ground Support materiel<sup>3</sup>  
 D—Administrative vehicles  
 G—Electronics  
 K—Tactical vehicles  
 L—Missiles  
 M—Weapons  
 N—Special weapons  
 T—Industrial supplies<sup>4</sup>

CLASS X—Materiel to Support Non-military Programs; e.g., Agricultural and Economic Development, not included in Classes I-IX.

<sup>1</sup> The Alpha Code for subclassification of Classes II, VII, and IX represents materiel category designators used in supply management, with the exception of A (Air) which is used throughout all classes of supply as applicable. Alpha Codes not utilized as materiel category designators have been assigned to the subclassifications for Classes I, III and V. The subclassification materiel designators (A through T) may be used in combination with the designated subclassifications, when appropriate and if desired, to further definitize a portion of a class of supply for planning purposes; e.g., use of Class V AL to designate ammunition, air missile. Additional codes may be utilized by the Services to satisfy a specific requirement. For example, to designate reparable or nonreparable, high dollar items, or for other selective management purposes. This additional permissive coding is not to be utilized in lieu of that designated for the major classification and subclassifications.

<sup>2</sup> Includes gratuitous health and welfare items.

<sup>3</sup> Includes power generators and construction, barrier, bridging, fire fighting, petroleum and mapping equipment.

<sup>4</sup> Includes bearings, block and tackle, cable, chain, wire rope, screws, bolts, studs, steel rods, plates, and bars.

<sup>5</sup> Commercial vehicles utilized in administrative motor pools.



## APPENDIX D

## EMPLOYMENT OF NONAIR DEFENSE WEAPONS AGAINST AIRCRAFT

**D-1. Policy**

Command responsibility for unit defense includes the use of organic weapons against low altitude air threat and imposes requirements for unit commanders to—

- a. Recognize the threat of enemy close air support, interdiction, and reconnaissance aircraft.
- b. Recognize the potential effect of the large volume of small arms fire that can be furnished by organic weapons against low-flying hostile aircraft.
- c. Recognize the necessity to train individual soldiers in aircraft identification and techniques of firing at aerial targets.
- d. Recognize the threat to friendly aircraft in failure to designate between hostile and friendly aircraft.
- e. Establish SOP for the identification and engagement of hostile aircraft to include how identification is accomplished, techniques of fire to be used, rules of engagement, and controls to be exercised.

**D-2. Standing Operating Procedures**

Based on the above an SOP should be established to cover as a minimum:

- a. *Policy.* (As stated above.)
- b. *Relation to Primary Mission.* (Primary mission is never prejudiced.) (Successful accomplishment of primary mission is paramount. Nothing

in the SOP should be construed as relieving the unit of its mission.)

c. *Relationship to Passive Air Defense.* (Passive air defense measures provide the most effective air defense for combat service support installations. In the event that passive air defense measures prove ineffective, the unit must aggressively employ the large volume of fire that organic small arms and automatic weapons can place against hostile aircraft.)

d. *Rule for Engagement.* (In the absence of orders to the contrary, authority to engage attacking aircraft is delegated to individual gunners. Engagement of other hostile aircraft will be ordered and supervised by unit leaders. Prior to ordering engagement, unit leaders will insure that such engagement does not adversely affect the accomplishment of the unit mission.)

e. *Firing Techniques.* (Aircraft will not be engaged when any of the following conditions are present: Positive identification of the aircraft cannot be determined, friendly troops will be endangered by engagement, friendly aircraft will be endangered by engagement, aircraft are not making hostile acts toward the installation and orders have not been issued to engage.)

f. *Techniques of Engagement.* (Aerial gunnery techniques applicable to all small arms and automatic weapons are indicated in FM 23-65.)

INDEX

	Paragraph	Page		Paragraph	Page
<b>Aerial:</b>			Helicopter pilots	2-6	2-3
Field artillery	1-4	1-2	Operations officer	2-6	2-3
Operations	4-2	4-1	Platoon commander	2-6	2-3
<b>Air movement plan</b>	4-10	4-16	Section leaders	2-6	2-3
<b>Battalion:</b>			<b>Employment:</b>		
Commander	2-2	2-1	Assignment	3-2	3-1
Field artillery, aerial field artillery.	2-4	2-2	Capabilities	3-3	3-1
Hqs, hqs and svc battery	2-5	2-2	Limitations	3-4	3-1
Mission	2-4	2-2	Planning	4-10	4-6
Staff	2-3	2-1	Positioning	4-7	4-5
<b>Battery:</b>			RSOP	4-8	4-5
Duties	2-6	2-3	Fires, coordination	4-5	4-2
Mission	2-6	2-3	<b>Gunnery:</b>		
<b>Classification:</b>			Call for fire	B-2	B-1
Aerial field artillery	1-3	1-1	Fire control	B-2	B-1
Airmobile artillery	1-3	1-1	General	B-1	B-1
<b>Combat organization</b>	4-1	4-1	Medical support	2-3	2-1
<b>Command/Control:</b>			Mission: gunnery, sample	B-2	B-1
Aviation officer	2-6	2-3	<b>Operations:</b>		
Commander	2-2	2-1	Atmosphere	4-3	4-1
Coordination	4-11	4-6	Density altitude	4-3	4-1
Fire direction	4-6	4-3	Limited visibility	4-3	4-1
Platoon leader	2-6	2-3	Night	4-3	4-1
Section leader	2-6	2-3	Support of airmobile forces	4-2	4-1
Staff	2-3	2-1	Support of ground mobile forces.	4-2	4-1
Surgeon	2-3	2-1	Visibility at night	4-3	4-1
<b>Concepts:</b>			Weather	4-3	4-1
Employment	1-5	1-2	<b>Planning:</b>		
Operational	1-6	1-5	Air movement	4-10	4-6
<b>Coordination:</b>			Ground tactical plan	4-10	4-6
Control	4-6	4-3	Landing plan	4-10	4-6
Fire support	4-5	4-2	Reverse sequence	4-10	4-6
FSCoord	4-5	4-2	RSOP	4-8	4-5
Principles	4-4	4-1	<b>Support:</b>		
Timing	4-5	4-2	Airmobile forces	4-2	4-1
<b>Definitions:</b>			Ground mobil forces	4-2	4-1
Aerial field artillery	1-4	1-2	Medical	2-3	2-1
Airmobile artillery	1-4	1-2	Weather	4-3	4-1
<b>Duties:</b>			Tactical employment	4-7	4-5
Battalion aviation safety officer.	2-3	2-1	<b>Weapons system:</b>		
Battalion commander	2-2	2-1	AH-1G (Hueycobra)	D-2	D-1
Battalion staff	2-3	2-1			
Battalion surgeon	2-3	2-1			
Crew chiefs	2-6	2-3			

By Order of the Secretary of the Army:

W. C. WESTMORELAND,  
*General, United States Army,*  
*Chief of Staff.*

Official:

KENNETH G. WICKHAM,  
*Major General, United States Army,*  
*The Adjutant General.*

Distribution:

To be distributed in accordance with DA Form 12-11 requirements for Air Delivery of Supplies and Equipment: Field Army.